

United States Patent [19]

Tamura et al.

[11] Patent Number: Des. 299,120

[45] Date of Patent: ** Dec. 27, 1988

[54] MOTORCYCLE

[75] Inventors: Gen Tamura, Tokyo; Kazuhiko Yokoyama; Yukinori Kawaguchi, both of Saitama, all of Japan

[73] Assignee: Honda Giken Kogyo Kabushiki Kaisha, Tokyo, Japan

[**] Term: 14 Years

[21] Appl. No.: 923,069

[22] Filed: Oct. 24, 1986

[30] Foreign Application Priority Data

May 19, 1986 [JP] Japan 61-18793

[52] U.S. Cl. D12/110

[58] Field of Search D12/110; 180/219, 225, 180/229

[56] References Cited

U.S. PATENT DOCUMENTS

D. 245,002 7/1977 Carpenter et al. D12/111
D. 273,854 5/1984 Ishiyama D12/110

Primary Examiner—James M. Gandy
Attorney, Agent, or Firm—Lyon & Lyon

[57] CLAIM

The ornamental design for a motorcycle, as shown.

DESCRIPTION

FIG. 1 is a front elevation view of a motorcycle showing our new design;
FIG. 2 is a rear elevation view thereof;
FIG. 3 is an elevation view of the left side thereof;
FIG. 4 is an elevation view of the right side thereof;
FIG. 5 is a top plan view thereof;
FIG. 6 is a bottom plan view thereof; and
FIG. 7 is a perspective view thereof.

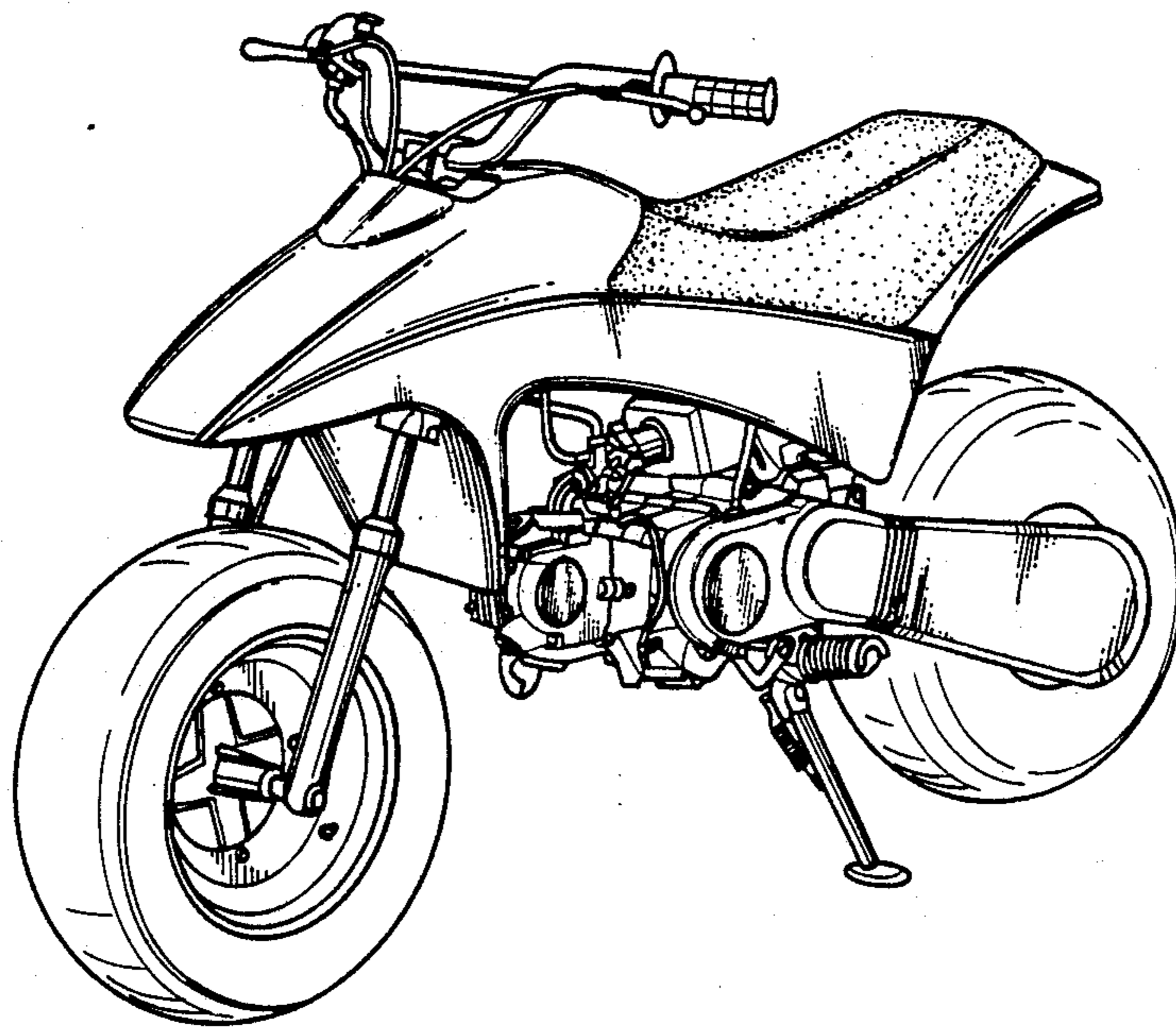

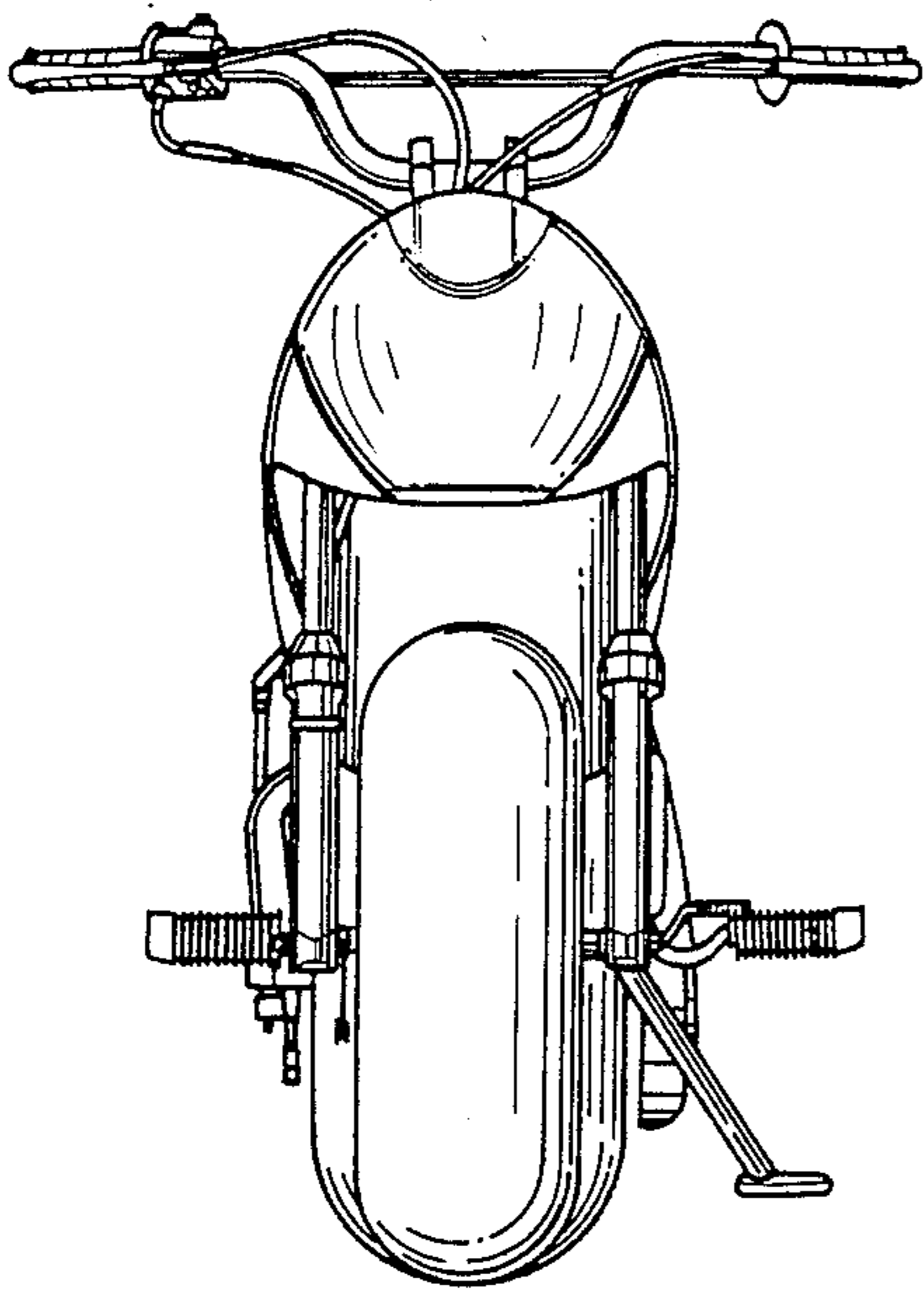

FIG. 1.

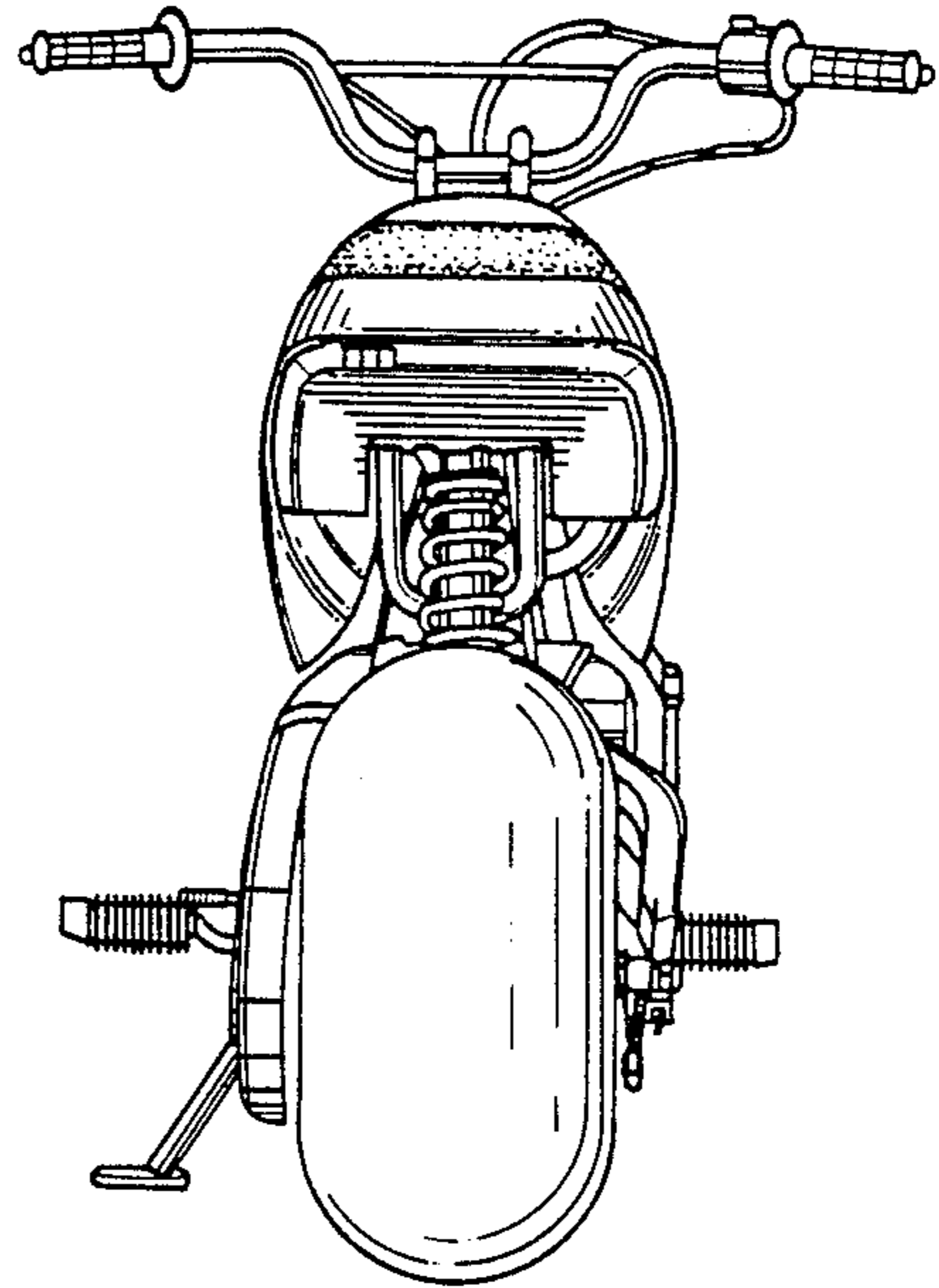

FIG. 2.

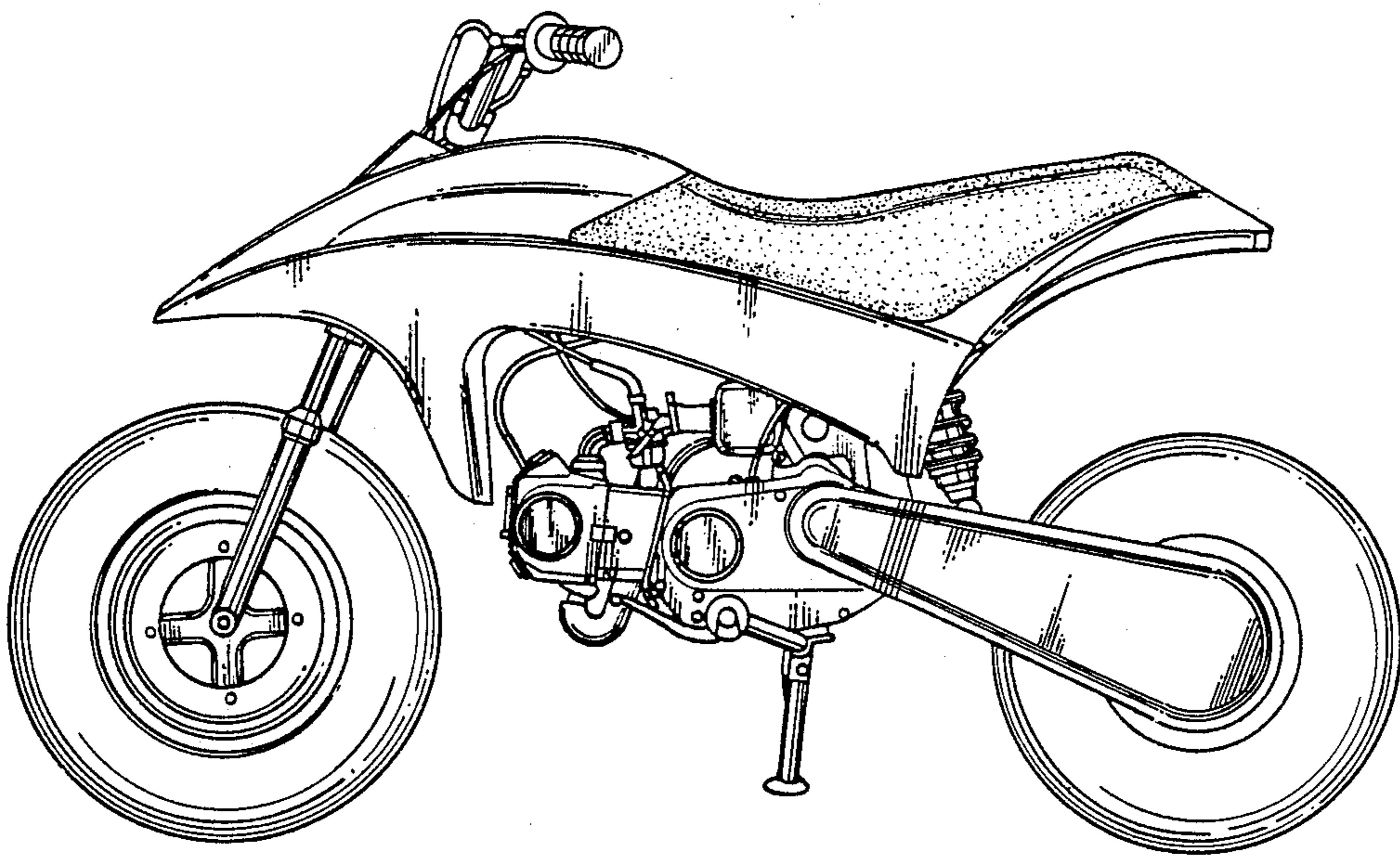

FIG. 3.

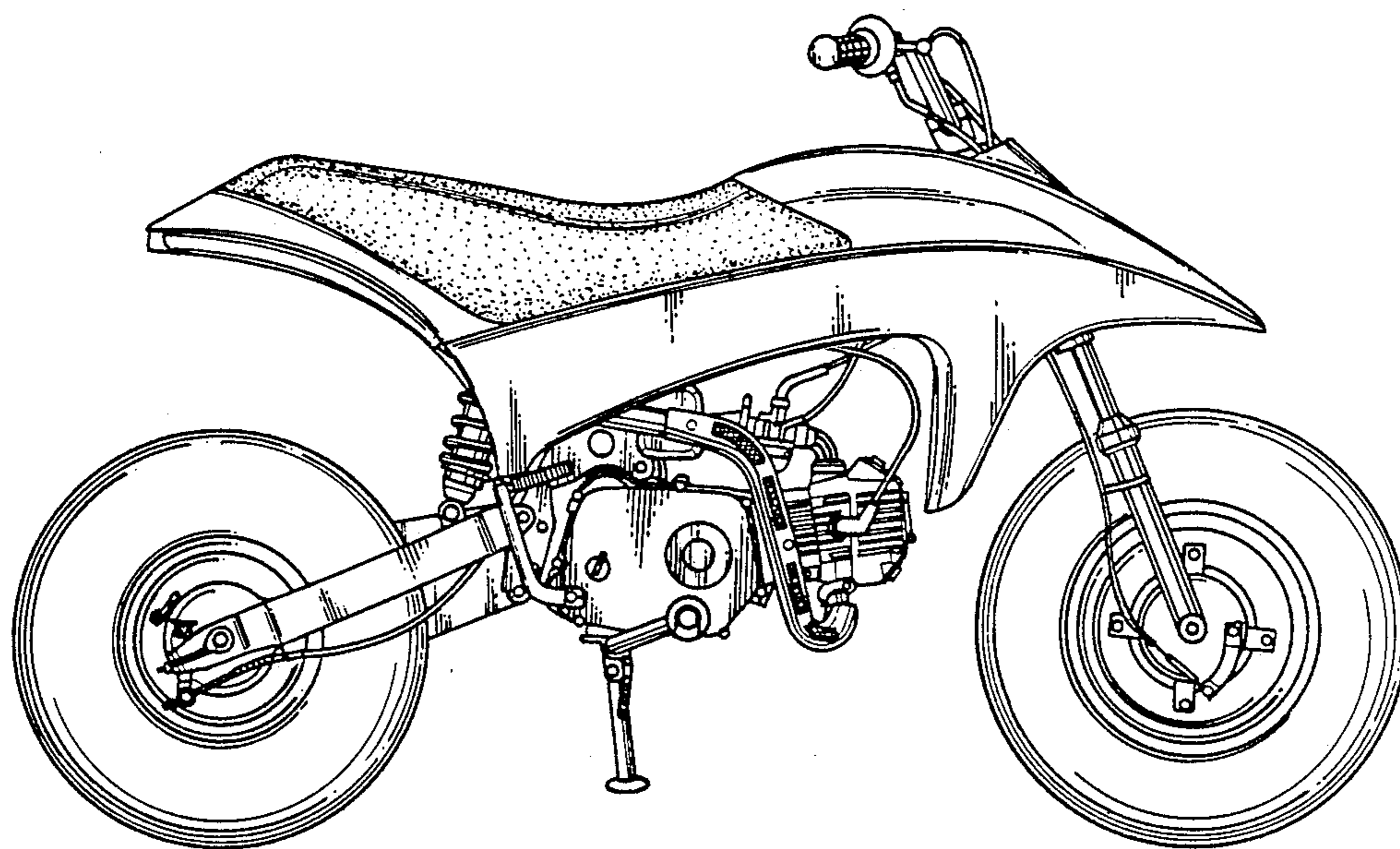

FIG. 4.

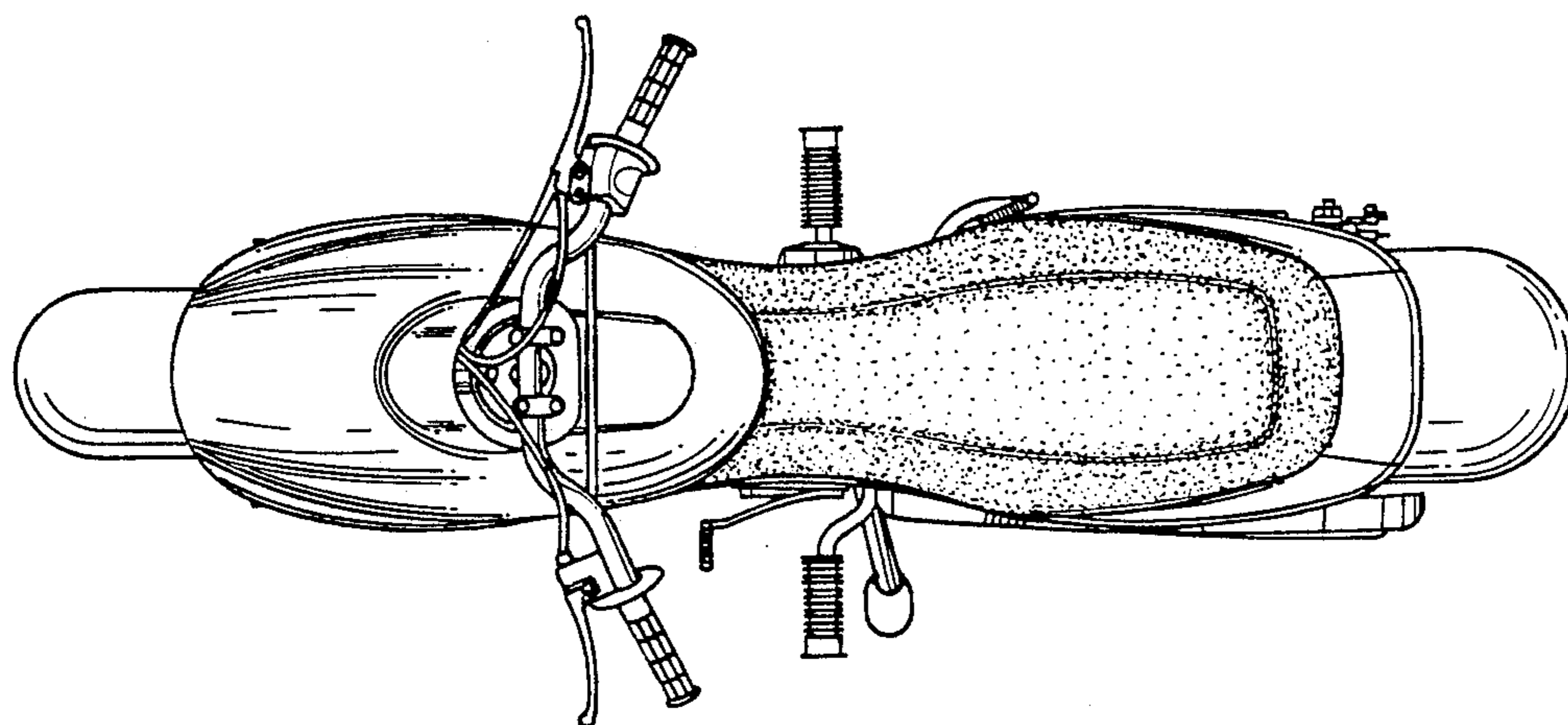

FIG. 5.

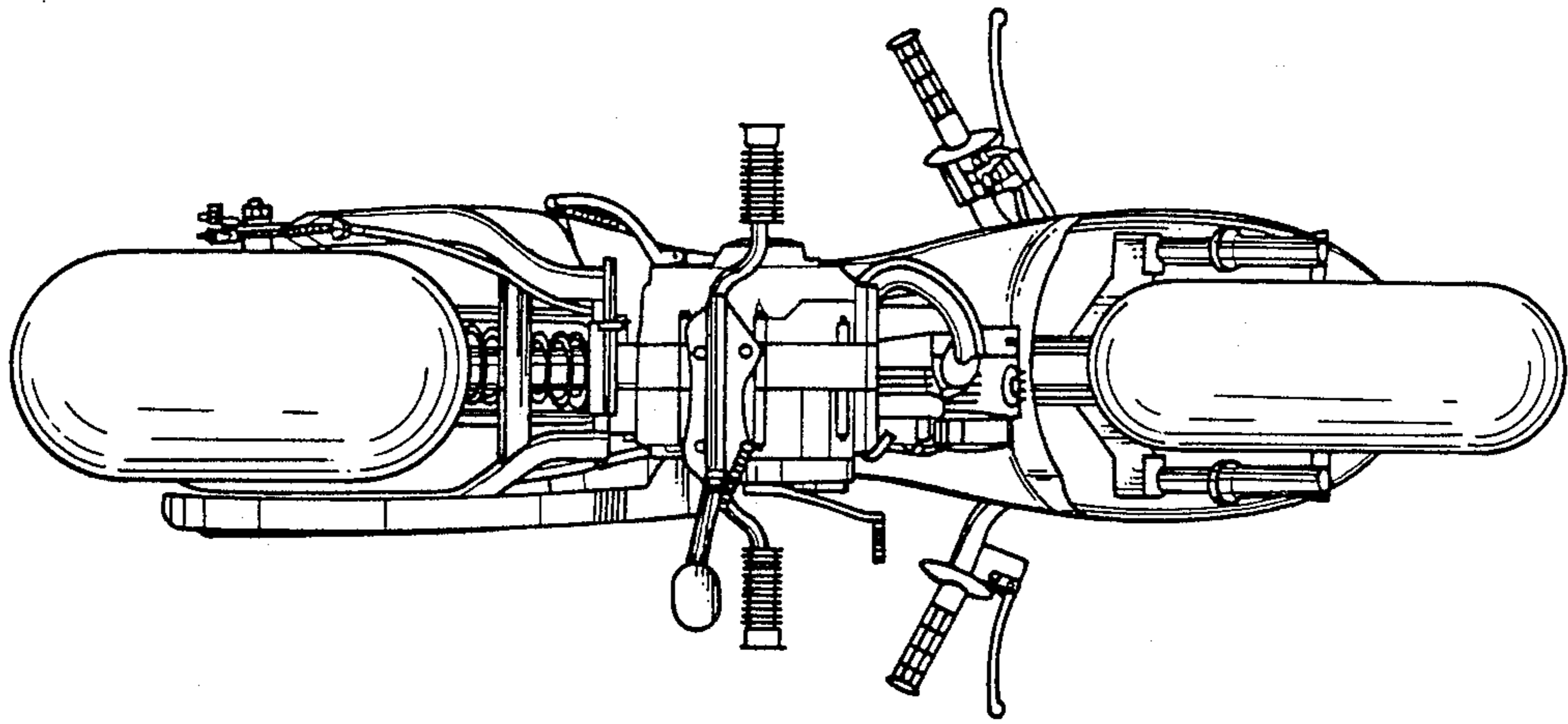

FIG. 6.

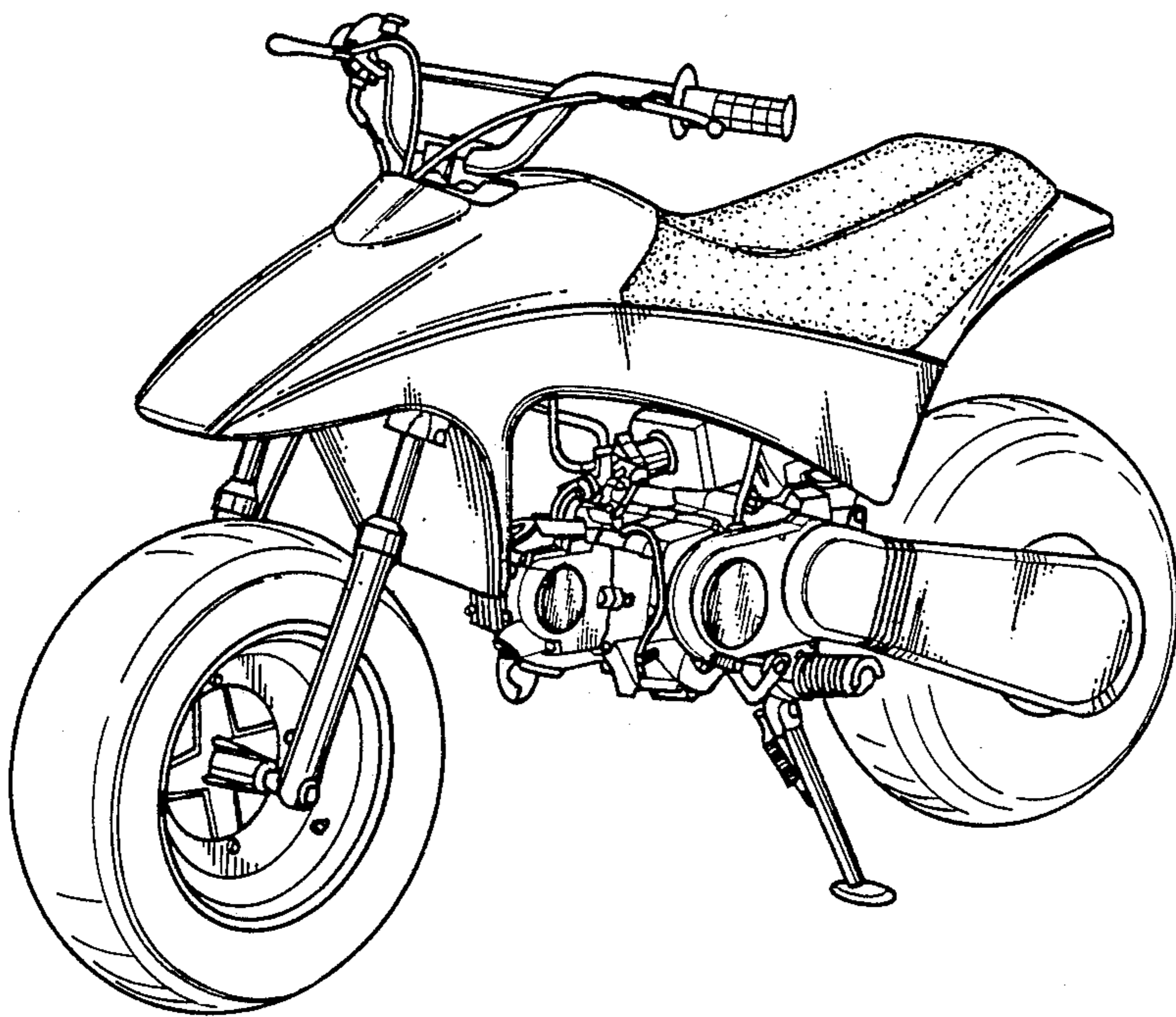

FIG. 7.