

[54] PICKUP TRUCK SIDEBOARD GUARD AND TIE DOWN UNIT

Primary Examiner—James M. Gandy
Attorney, Agent, or Firm—Wells, St. John & Roberts

[76] Inventors: Donald G. Renn, deceased, late of Lewiston, Id.; by Lou J. Renn, personal representative, 2615 Country Club Dr., Lewiston, Id. 83501

[57] CLAIM

The ornamental design for a pickup truck sideboard guard and tie down unit, as shown and described.

[**] Term: 14 Years

DESCRIPTION

[21] Appl. No.: 827,910

FIG. 1 is a perspective view of a pickup truck sideboard guard and tie down unit, showing my new design, the broken lines indicating a truck are shown for illustrative purposes only and form no part of the claimed design; FIG. 2 is an enlarged top plan view thereof, the opposite bottom surface being unornamented; FIG. 3 is an enlarged side elevation view thereof as seen from the right in FIG. 1; FIG. 4 is an enlarged side elevation view opposite the side illustrated in FIG. 3; and FIG. 5 is an enlarged end elevation view thereof, the opposite end being a mirror image thereof.

[22] Filed: Feb. 10, 1986

[52] U.S. Cl. D12/155; D12/190

[58] Field of Search D12/156, 98, 155; 410/110, 115, 106

[56] References Cited

U.S. PATENT DOCUMENTS

4,253,785 3/1981 Bronstein 410/110

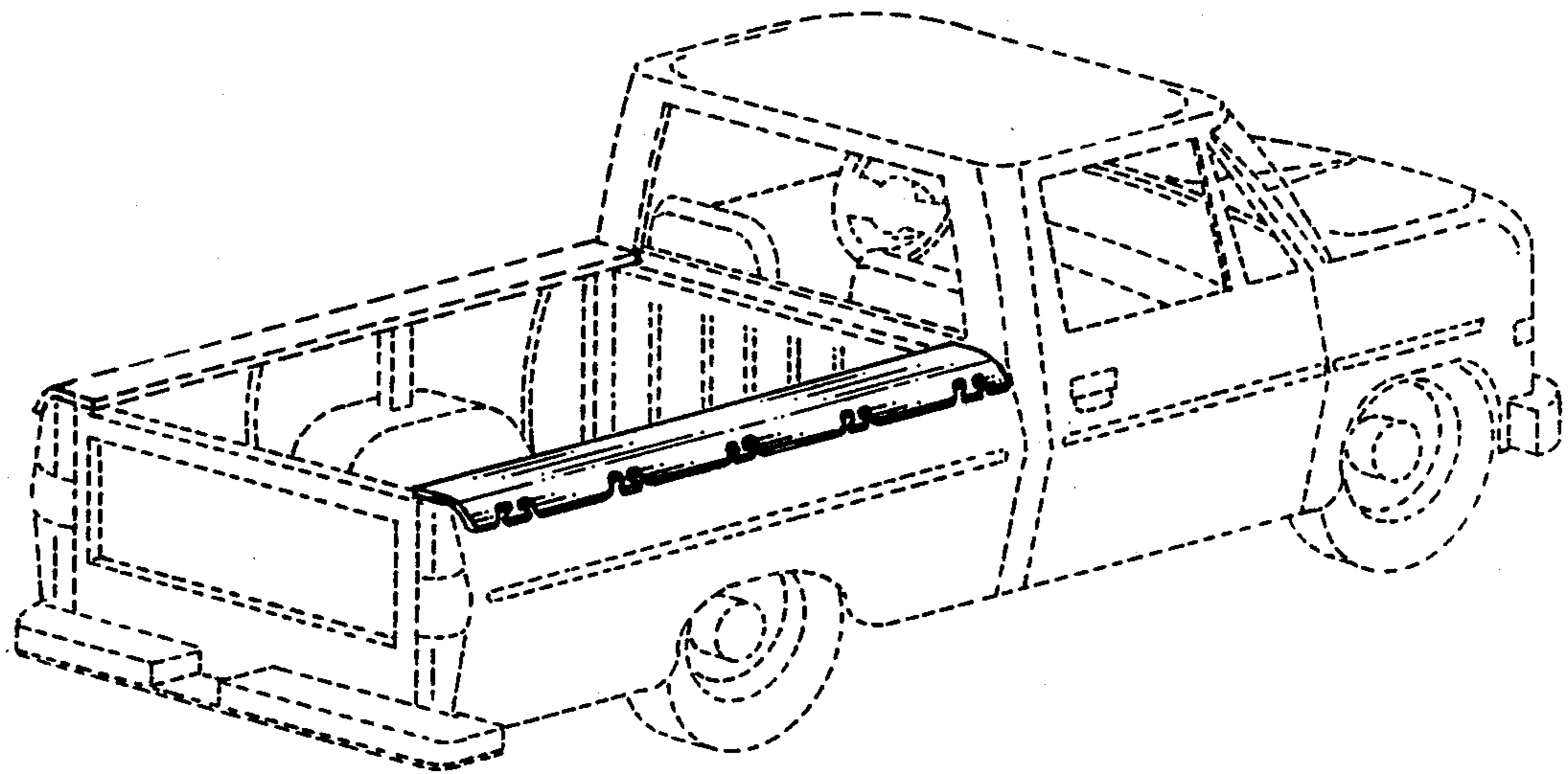

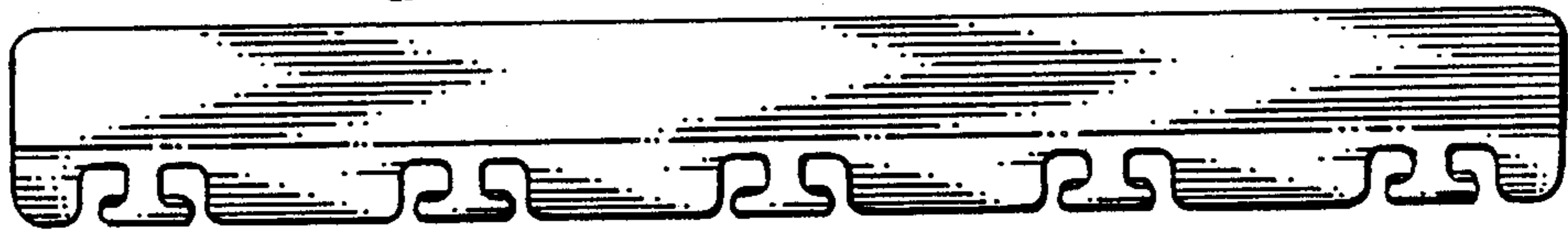
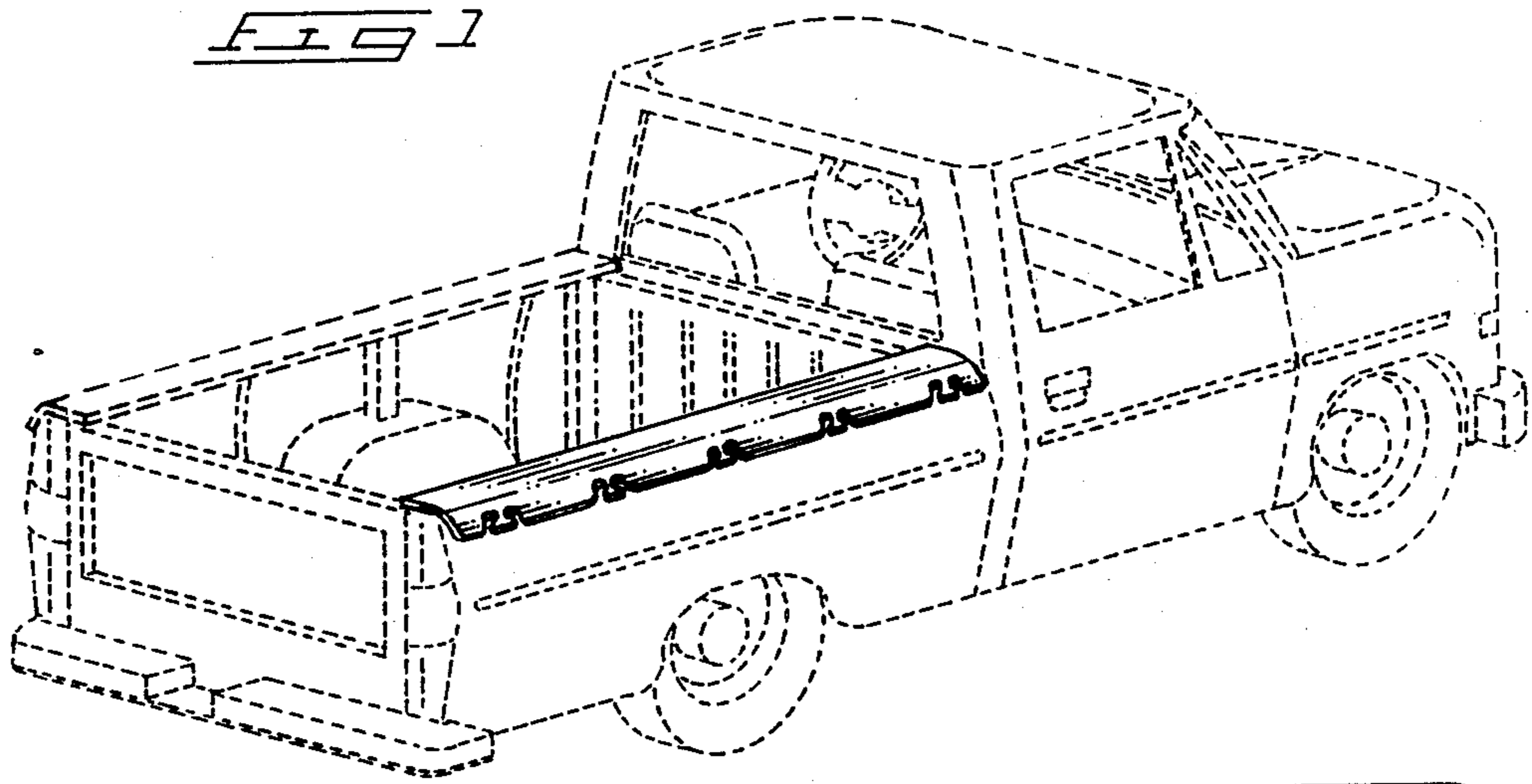

FIG 2



FIG 3



FIG 4

