

[54] MOTORCYCLE

[75] Inventors: Makoto Kitagawa, Tokyo; Nobuyuki Kyogoku, Saitama, both of Japan

[73] Assignee: Honda Giken Kogyo Kabushiki Kaisha, Tokyo, Japan

[**] Term: 14 Years

[21] Appl. No.: 462,223

[22] Filed: Jan. 31, 1983

[30] Foreign Application Priority Data

Jul. 30, 1982 [JP] Japan 57-34988

[52] U.S. Cl. D12/110

[58] Field of Search D12/110; 180/219, 221, 180/229, 231

[56] References Cited

U.S. PATENT DOCUMENTS

D. 271,865 12/1983 Morioka et al. D12/110

OTHER PUBLICATIONS

Cycle World, 1/82, p. 47, Yamaha Seca 750 Motorcycle, top of page.

Cycle World, 3/82, p. 37, Kawasaki GPz 750 Motorcycle.

Primary Examiner—James M. Gandy
Attorney, Agent, or Firm—Lyon & Lyon

[57] CLAIM

The ornamental design for a motorcycle, as shown.

DESCRIPTION

FIG. 1 is a front elevation view of a motorcycle showing our new design;

FIG. 2 is a rear elevation view thereof;

FIG. 3 is a left side elevation view thereof;

FIG. 4 is a right side elevation view thereof;

FIG. 5 is a top plan view thereof;

FIG. 6 is a bottom plan view thereof; and

FIG. 7 is a perspective view thereof.

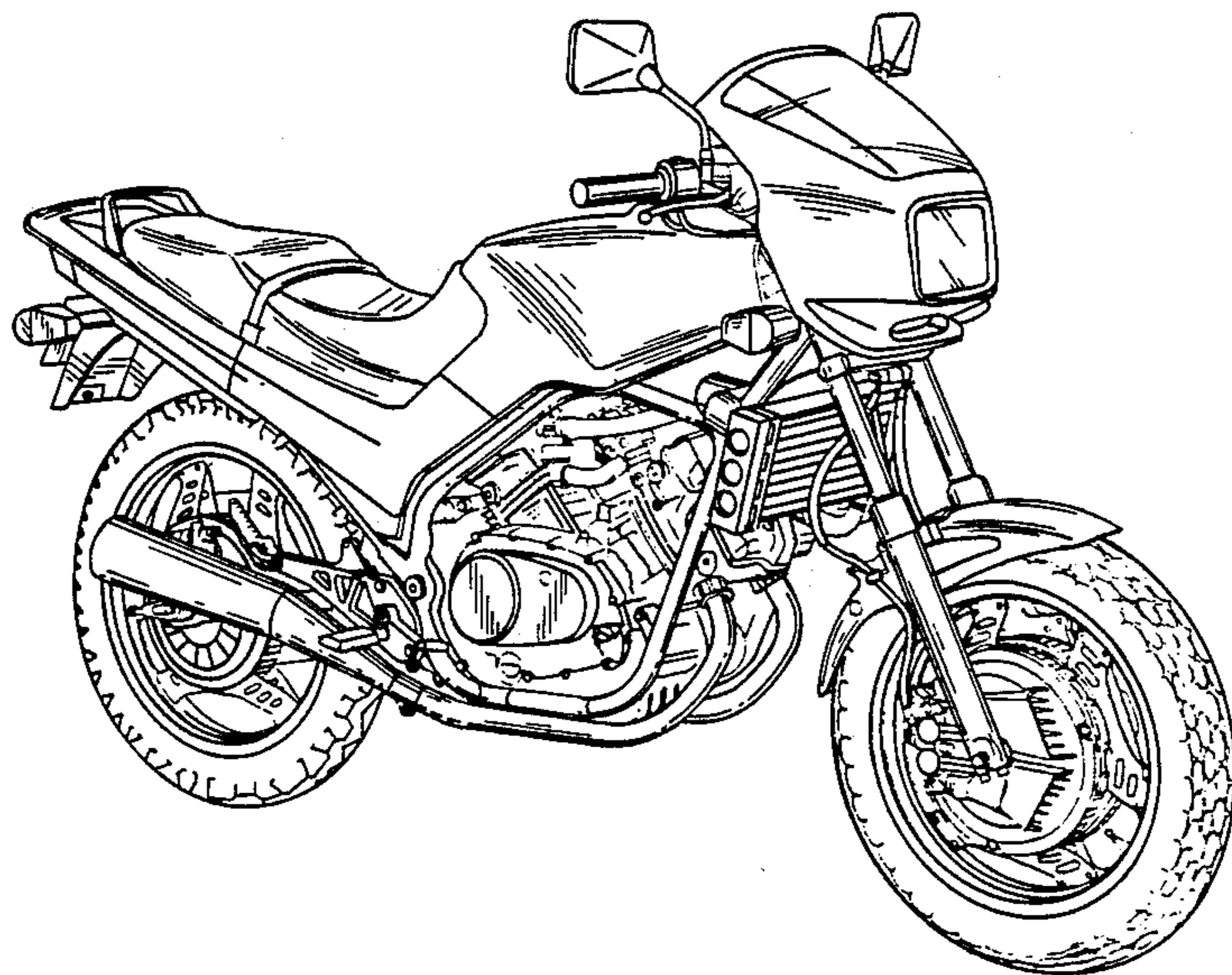

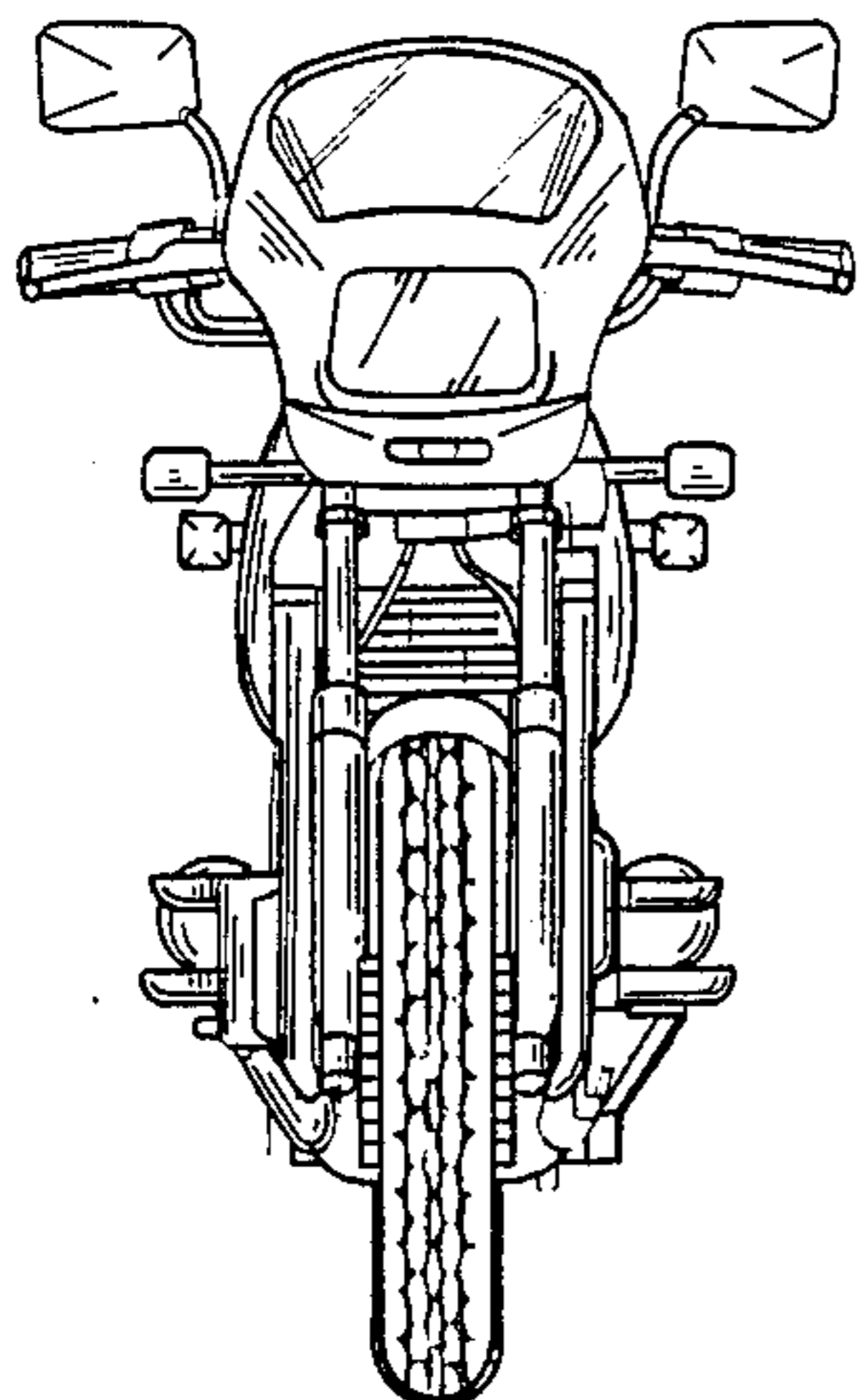

FIG. 1.

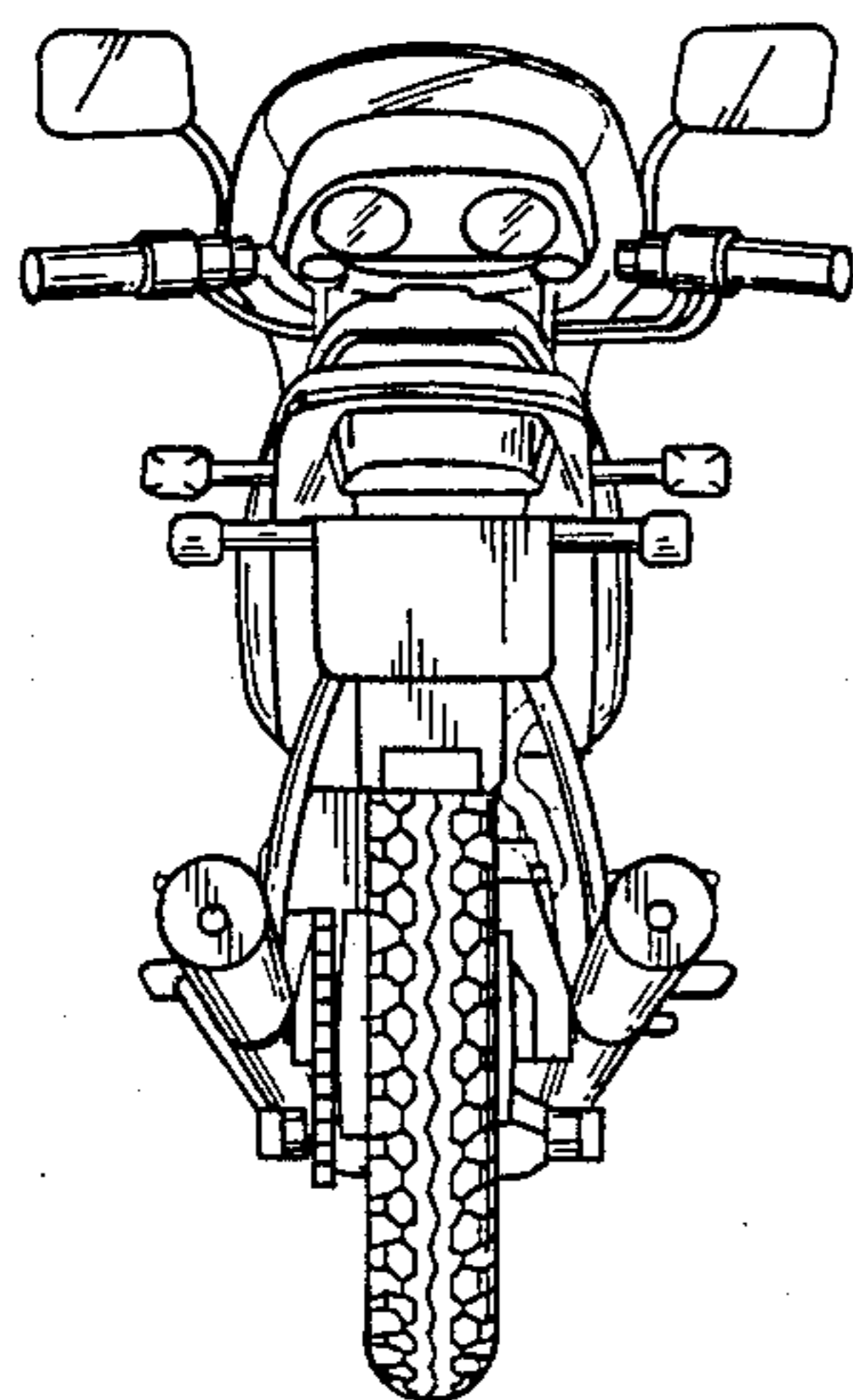

FIG. 2.

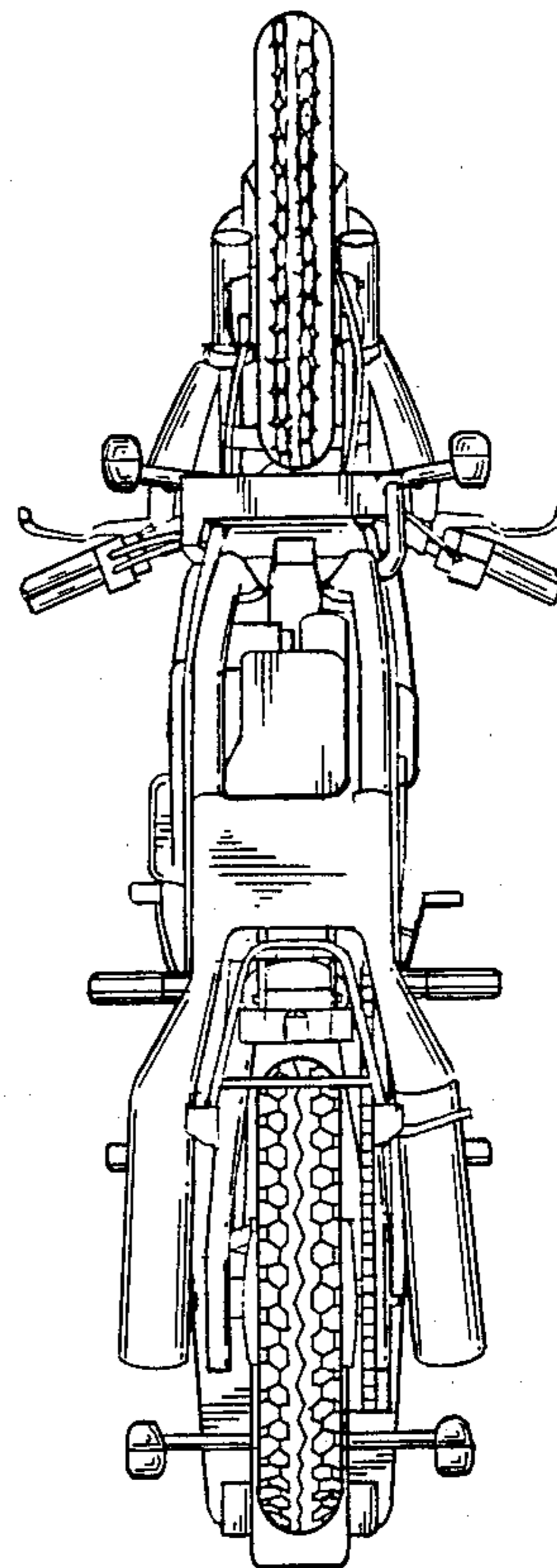

FIG. 6.

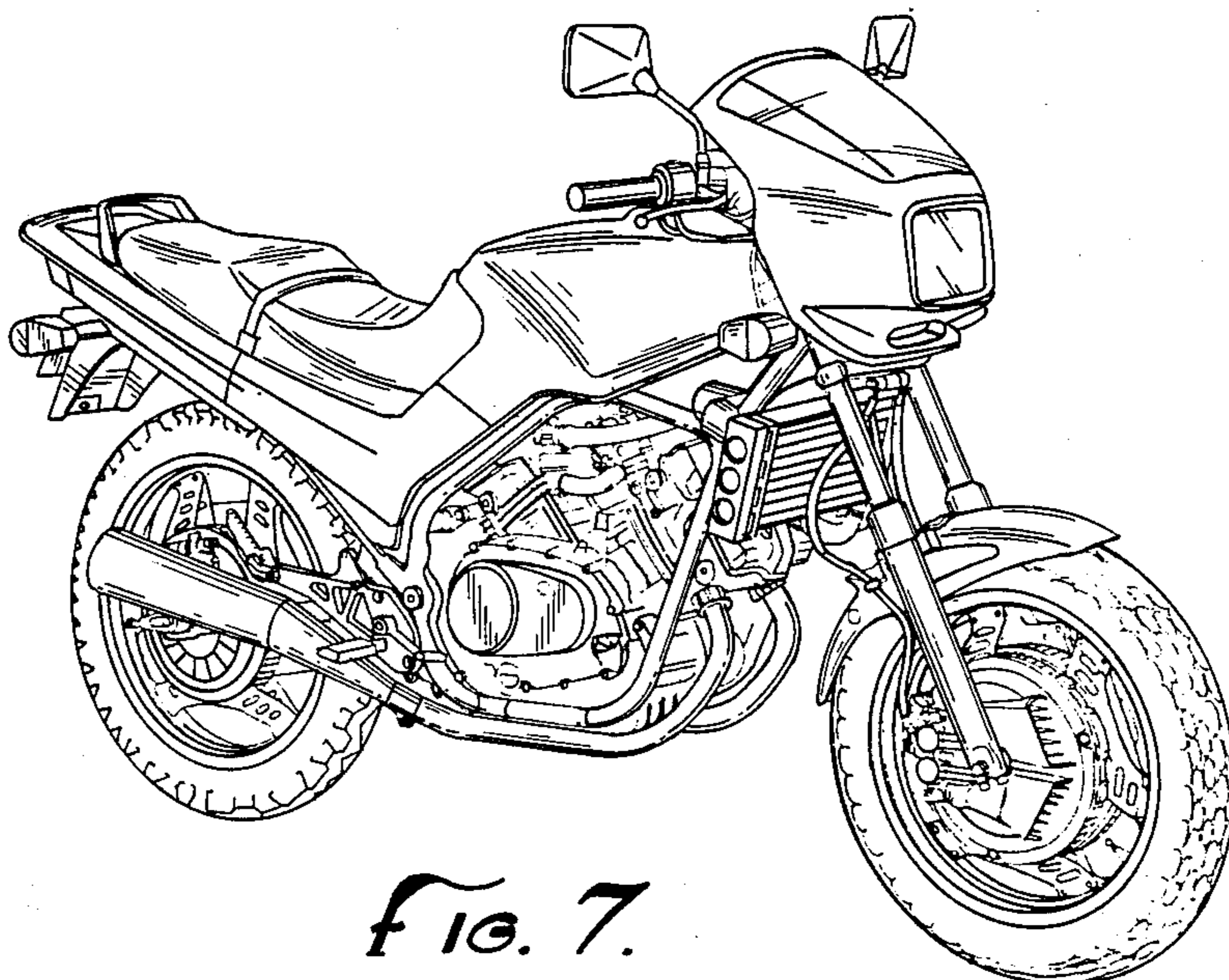

FIG. 7.

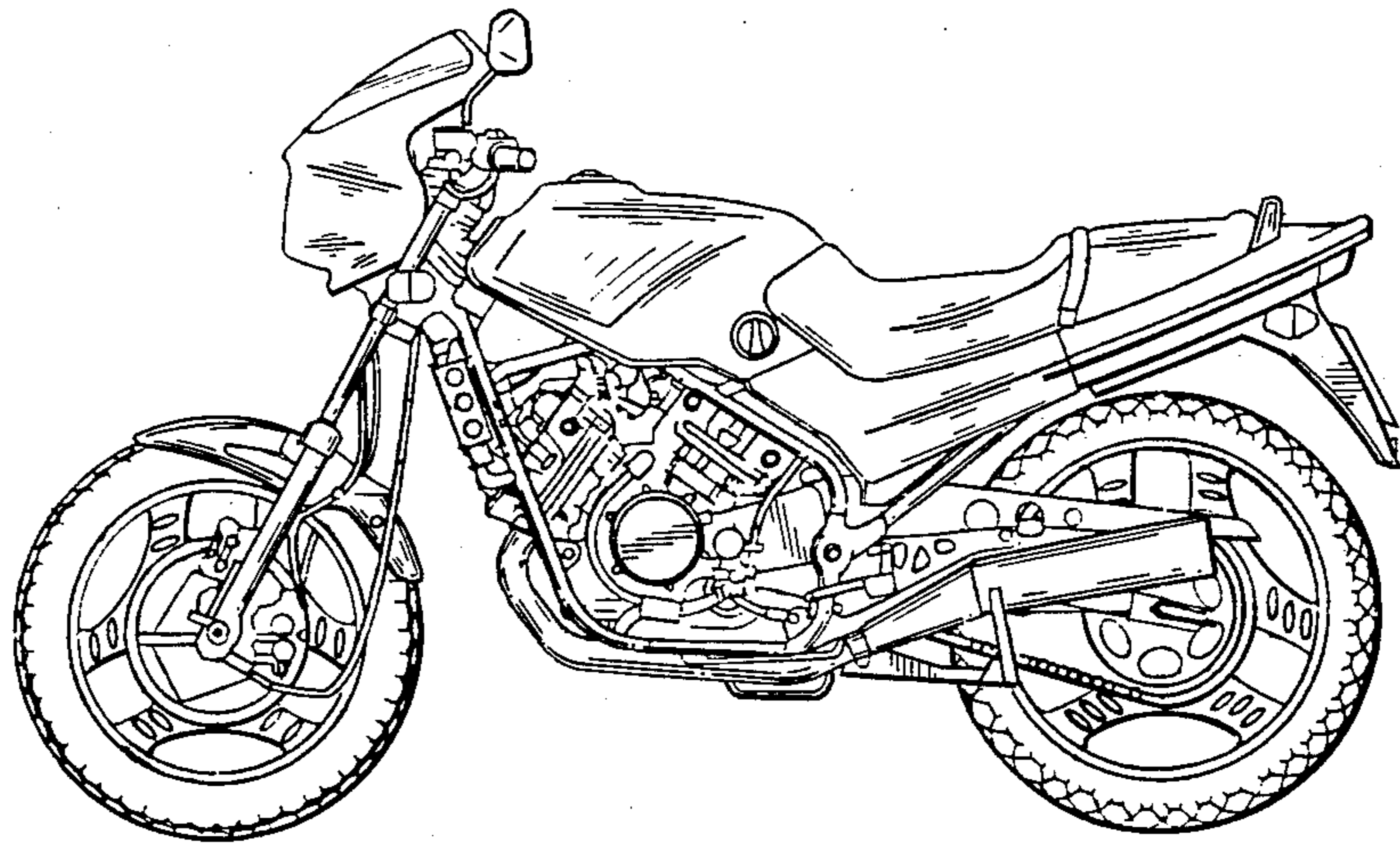

FIG. 3.

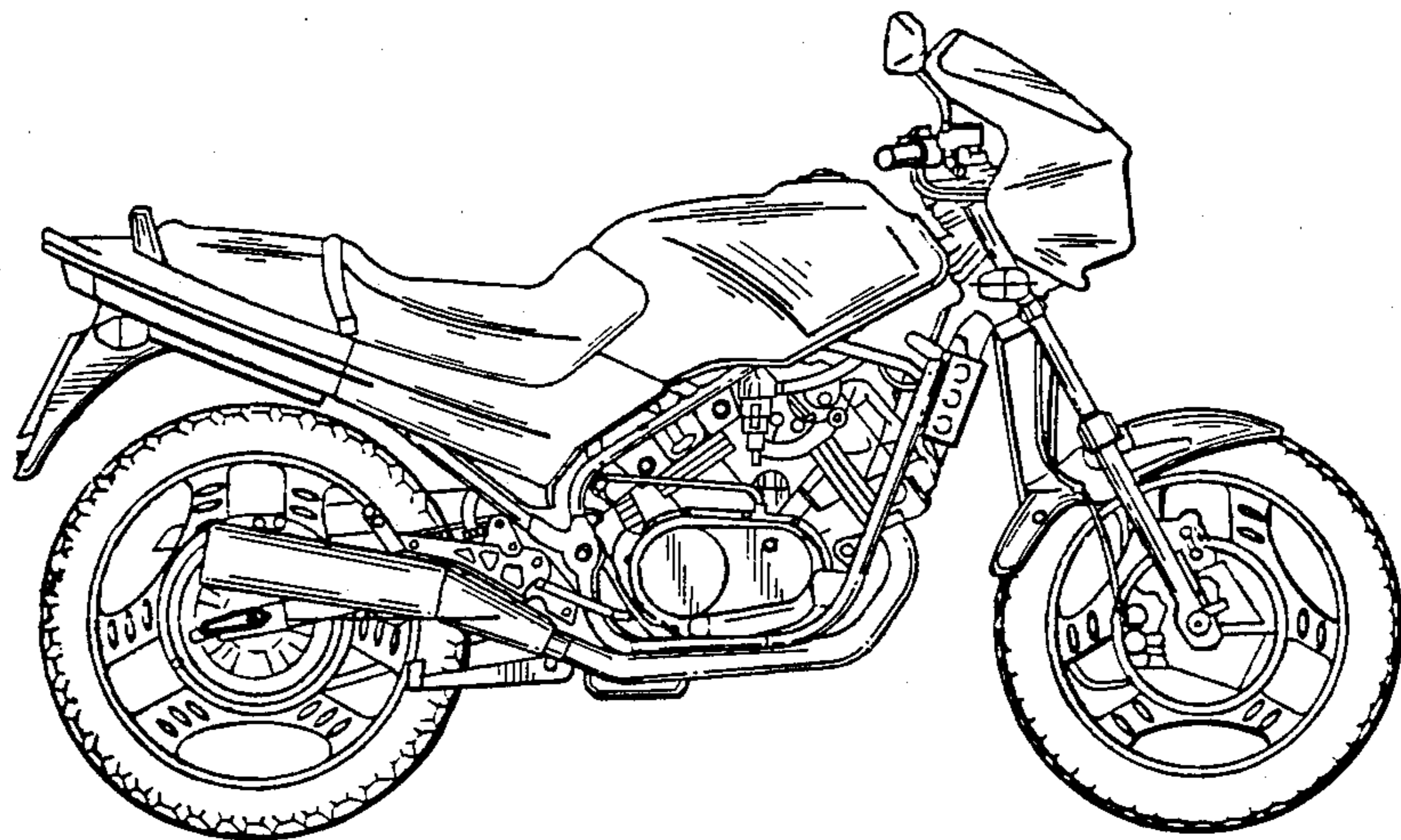

FIG. 4.

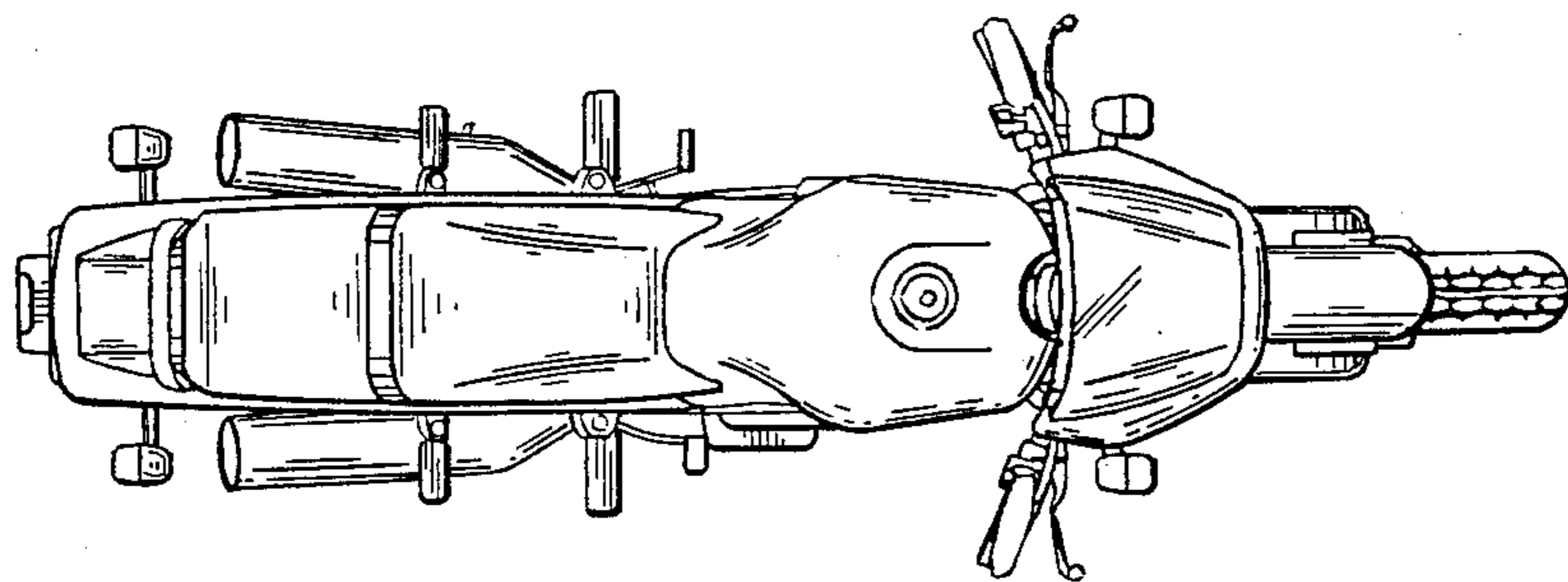

FIG. 5.