

[54] **VEHICLE RAMP**

[76] **Inventor:** W. Jeffrey Van Buskirk, P.O. Box
 1385, 302 South Leach St., Hobbs, N.
 Mex. 88240

[**] **Term:** 14 Years

[21] **Appl. No.:** 864,904

[22] **Filed:** May 19, 1986

[52] **U.S. Cl. D34/32**

[58] **Field of Search D34/28, 32; 193/41,
 193/38; 14/71.1, 69.5, 71.7; 254/88, 122, 124;
 414/537**

[56] **References Cited**

U.S. PATENT DOCUMENTS

D. 231,092	4/1974	West	D34/32
3,915,430	10/1975	Chromy et al.	254/88
4,114,854	9/1978	Clark	254/122
4,638,610	1/1987	Heikkinen	254/122
4,659,066	4/1987	Van Lierop	254/122
4,718,519	1/1988	Barker	254/122

Primary Examiner—Wallace R. Burke

Assistant Examiner—Kay H. Chin

Attorney, Agent, or Firm—Burns, Doane, Swecker &
 Mathis

[57] **CLAIM**

The ornamental design for a vehicle ramp, as shown
 and described.

DESCRIPTION

FIG. 1 is a left side elevational view of a vehicle ramp showing my new design;
 FIG. 2 is a left side elevational view thereof, shown in a collapsed condition;
 FIG. 3 is a rear elevational view thereof;
 FIG. 4 is a front elevational view thereof;
 FIG. 5 is a top plan view thereof;
 FIG. 6 is a bottom plan view thereof;
 FIG. 7 is a left side elevational view of a jack portion of the vehicle ramp, it being understood that the jack portion is shown separately for clarity of illustration;
 FIG. 8 is a front elevational view of FIG. 7;
 FIG. 9 is a top plan view of FIG. 7;
 FIG. 10 is a bottom plan view of FIG. 7;
 FIG. 11 is a top plan view of a ramp portion of the vehicle ramp, the ramp portion is shown separately for clarity of illustration;
 FIG. 12 is a front elevational view of FIG. 11;
 FIG. 13 is a bottom plan view of FIG. 11;
 FIG. 14 is a rear elevational view of FIG. 11;
 FIG. 15 is a left side elevational view of FIG. 11;
 FIG. 16 is a left side elevational view of a horizontal base platform section of the vehicle ramp, the horizontal base platform section is shown separately for clarity of illustration;
 FIG. 17 is a top plan view of FIG. 16;
 FIG. 18 is a bottom plan view of FIG. 16;
 FIG. 19 is a rear elevational view of FIG. 16; and
 FIG. 20 is a front elevational view of FIG. 16.
 The right side views of FIGS. 1, 2, 7, 15 and 16 are mirror images of those shown.

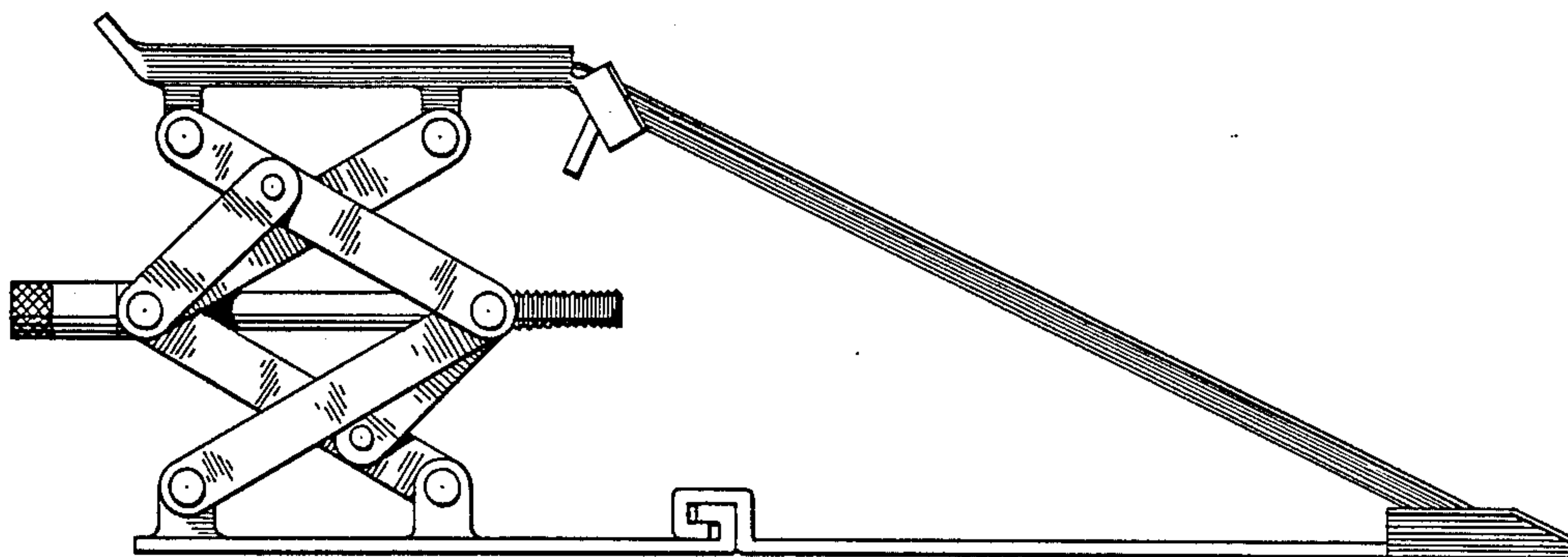

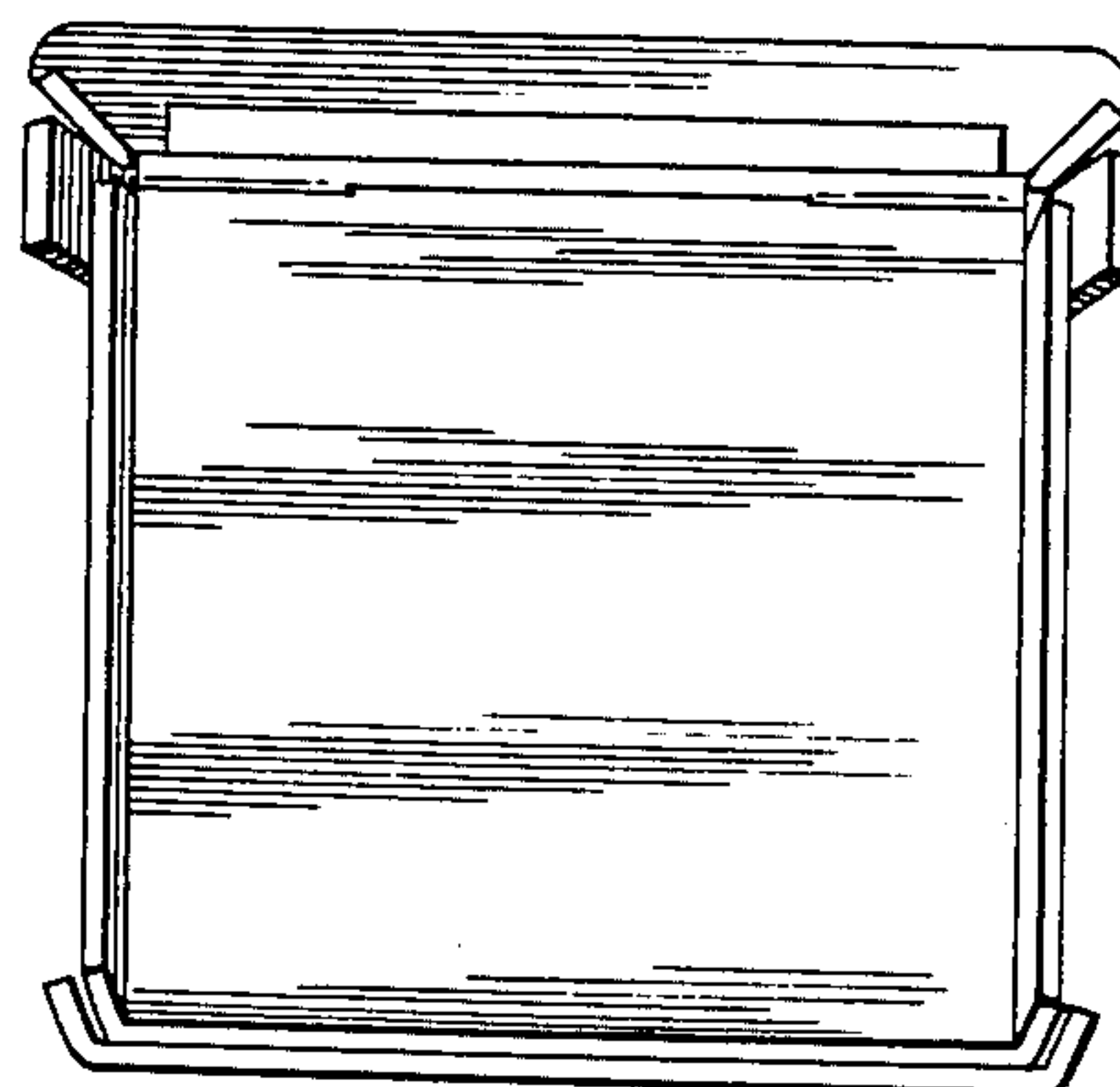
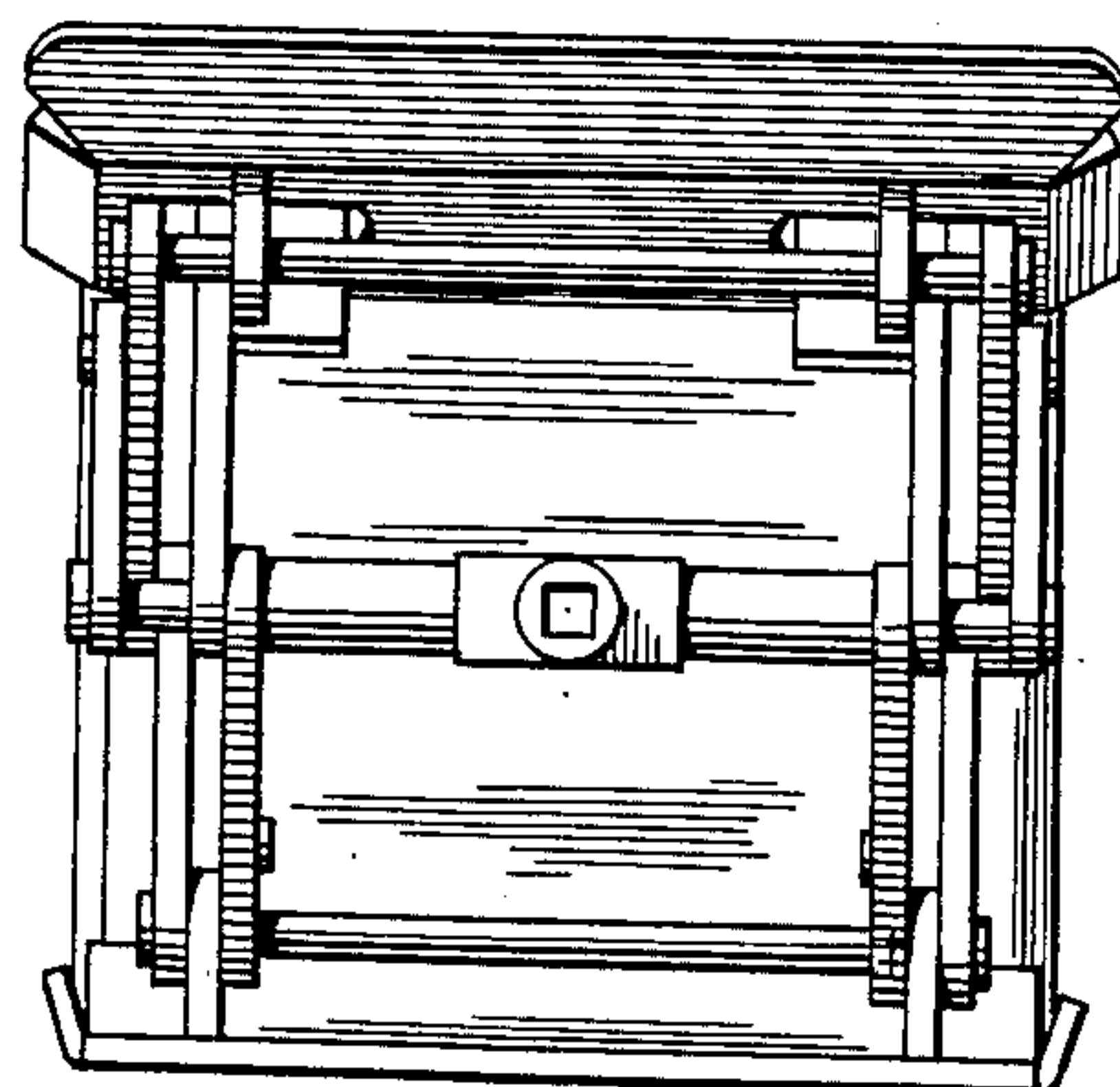
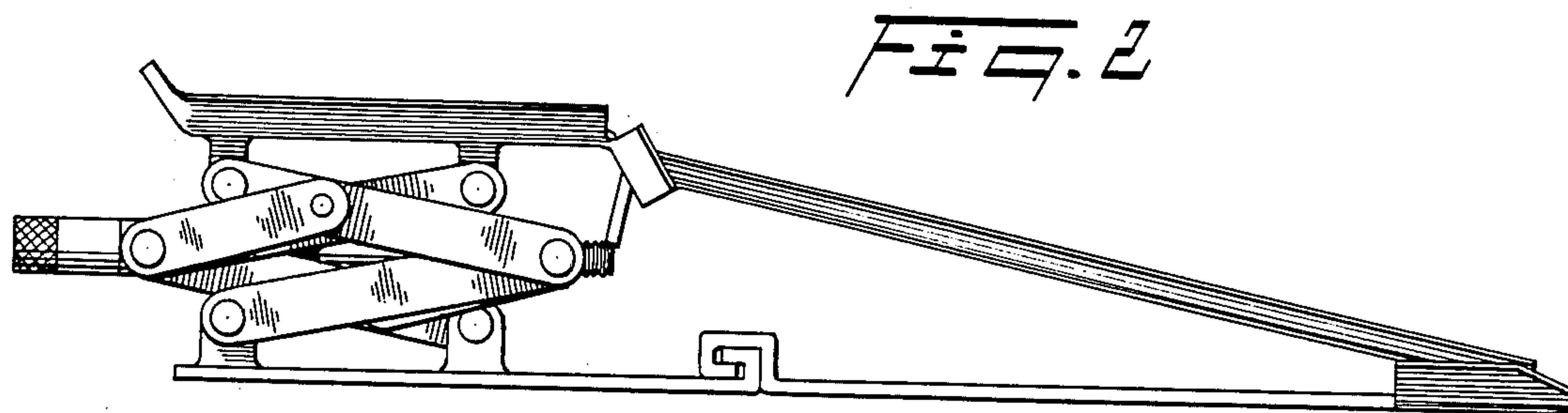
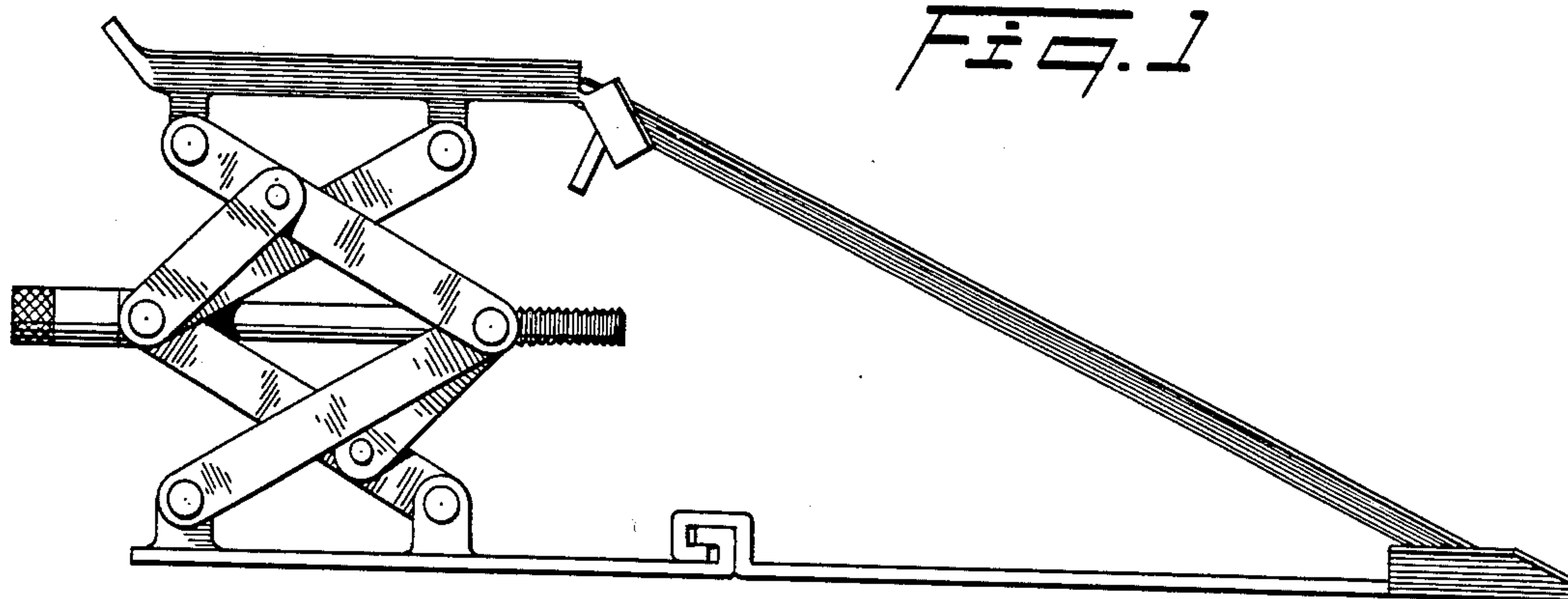

FIG. 5

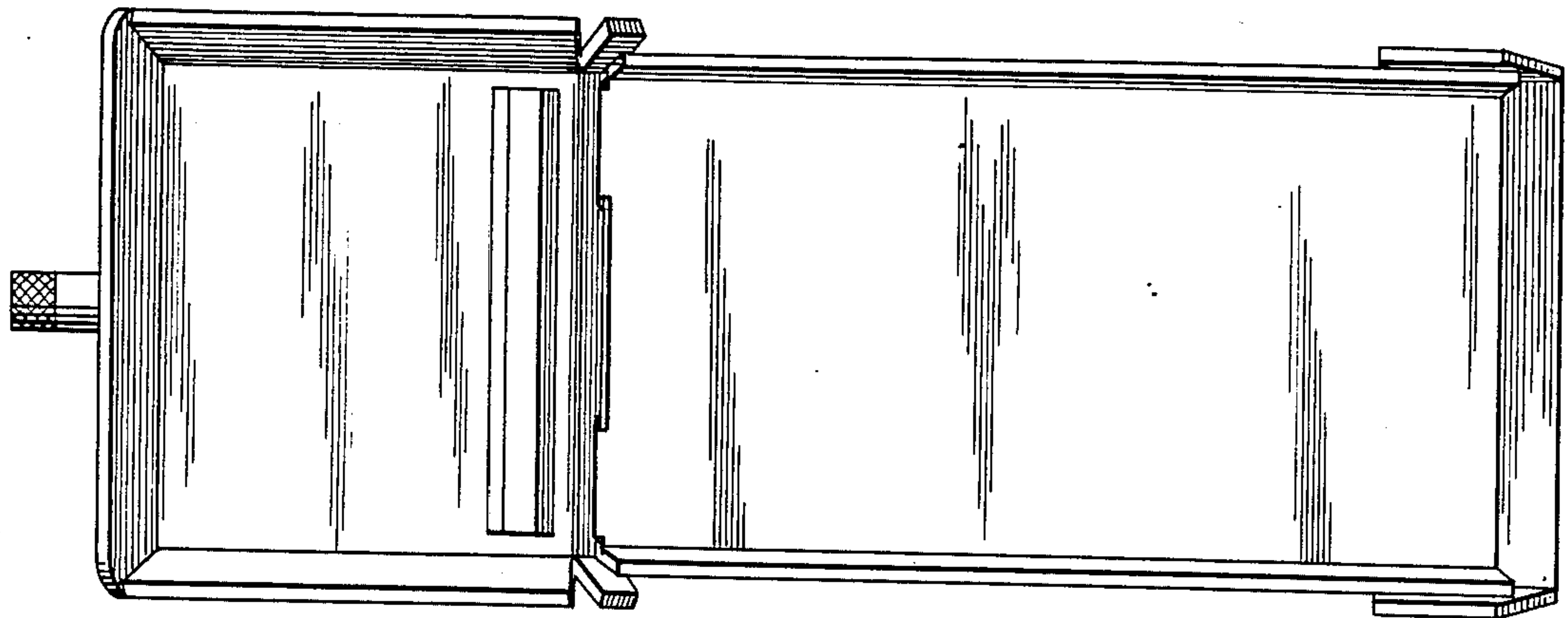

FIG. 6

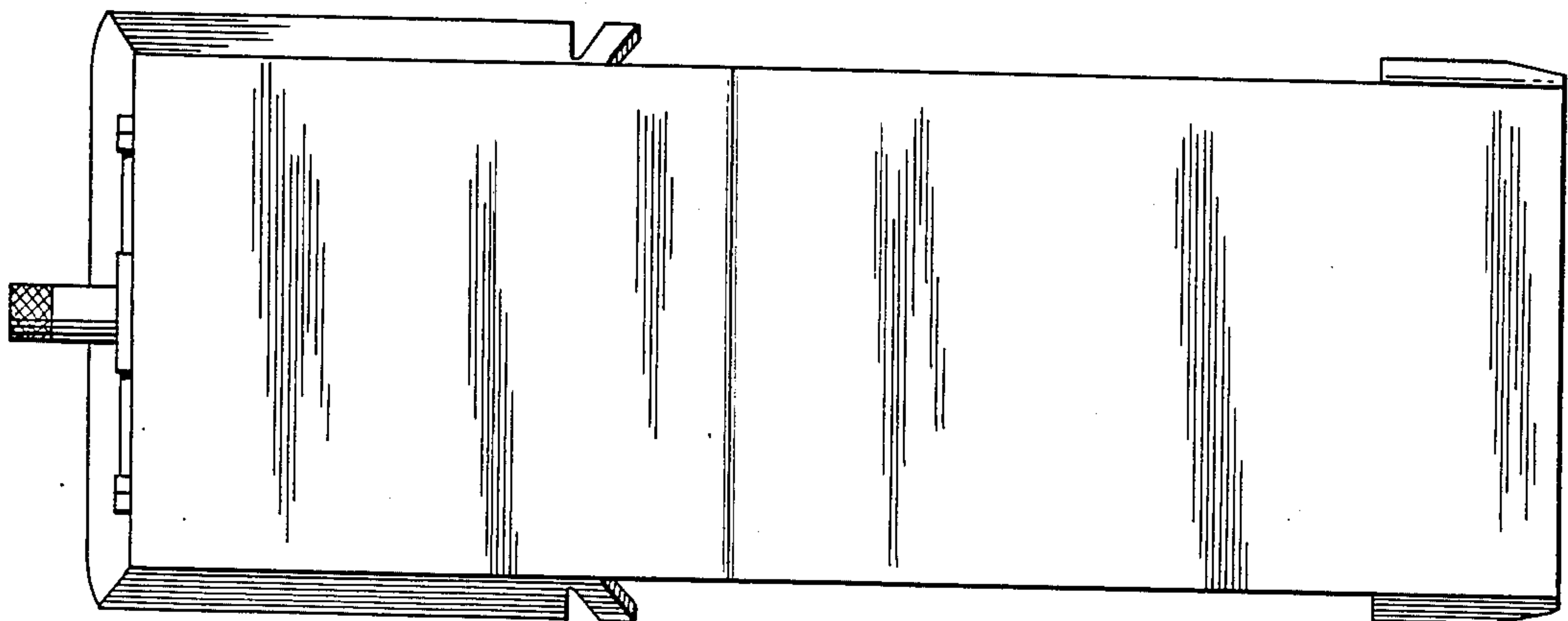

FIG. 7

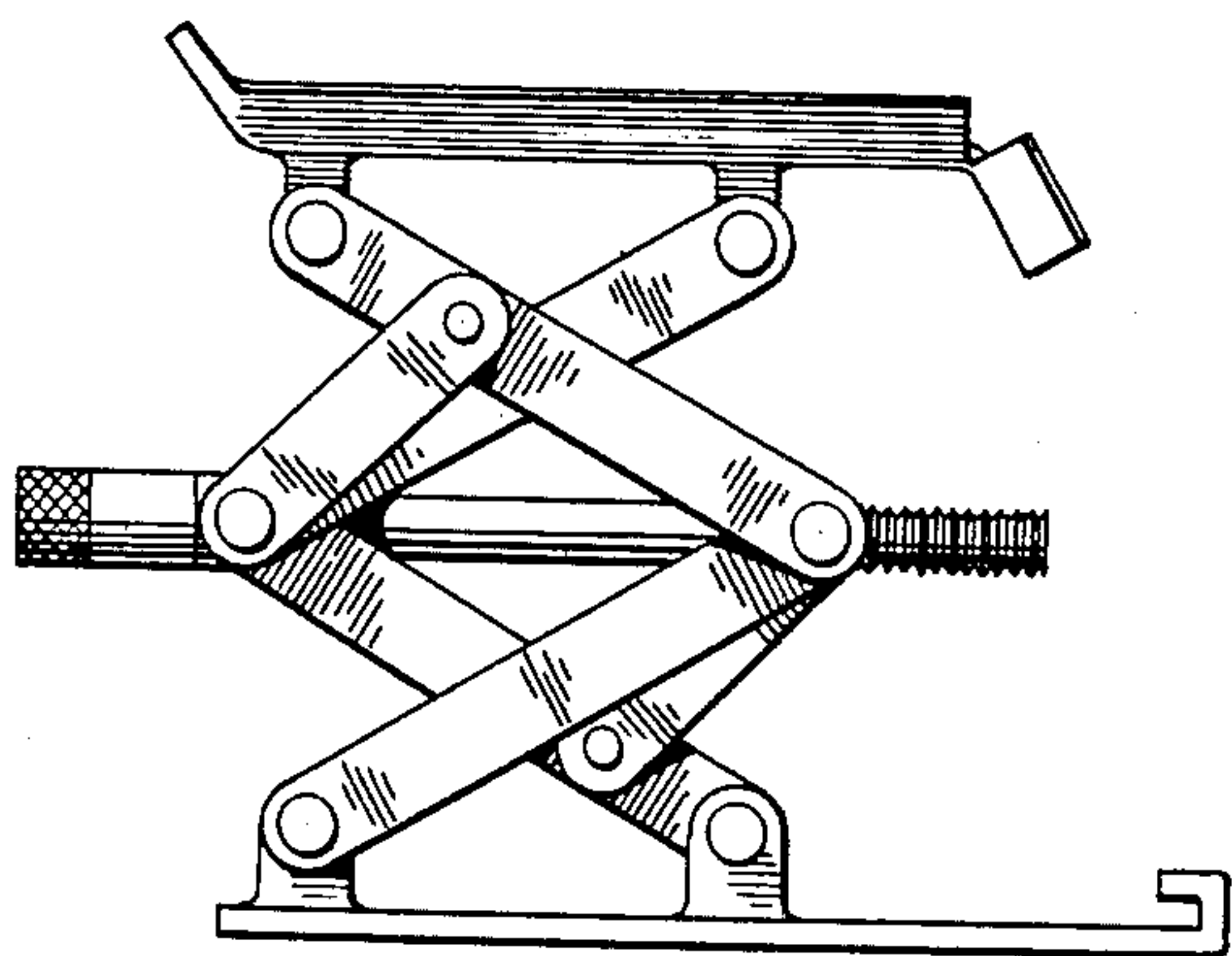

FIG. 8

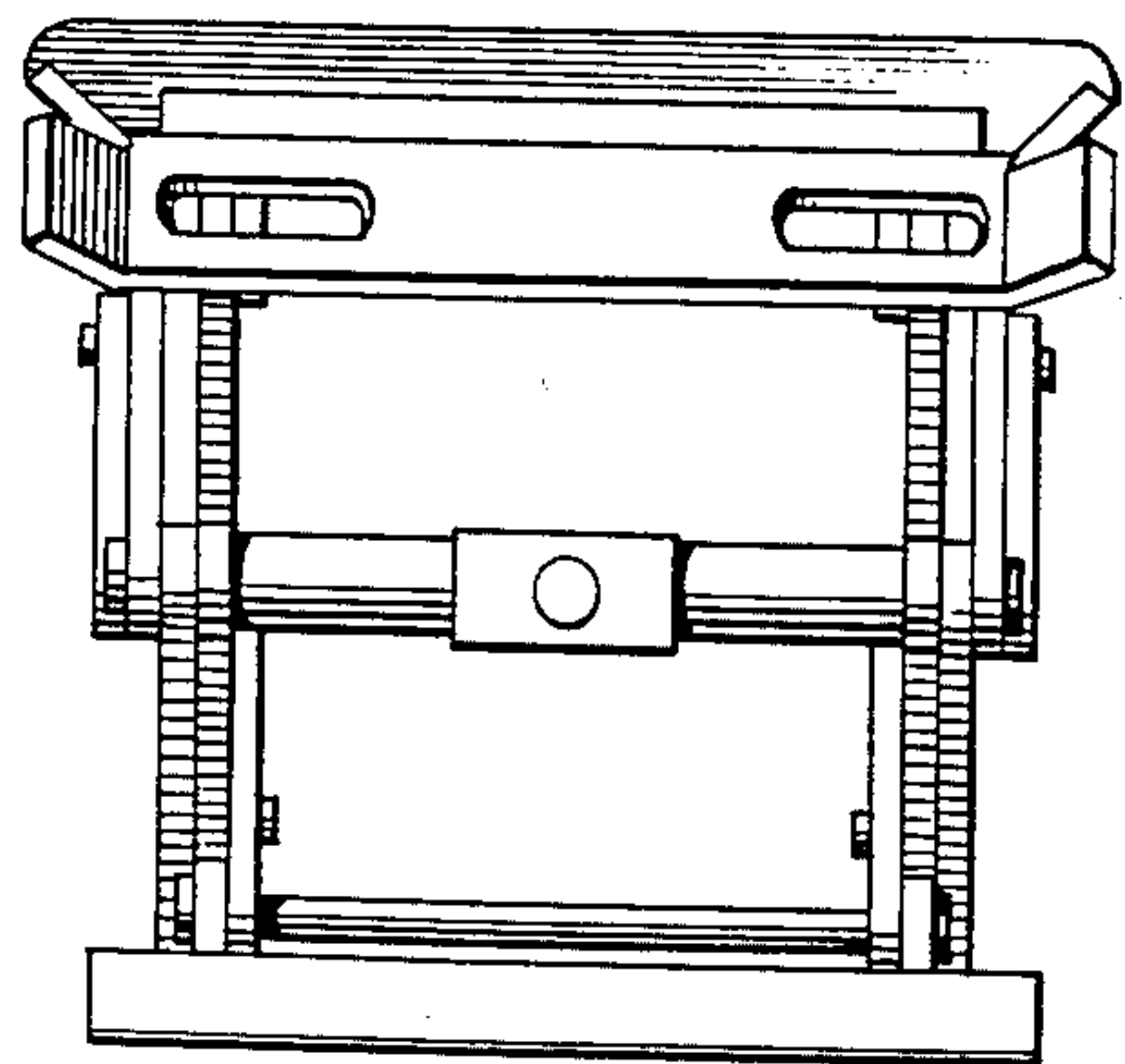

Fig. 9

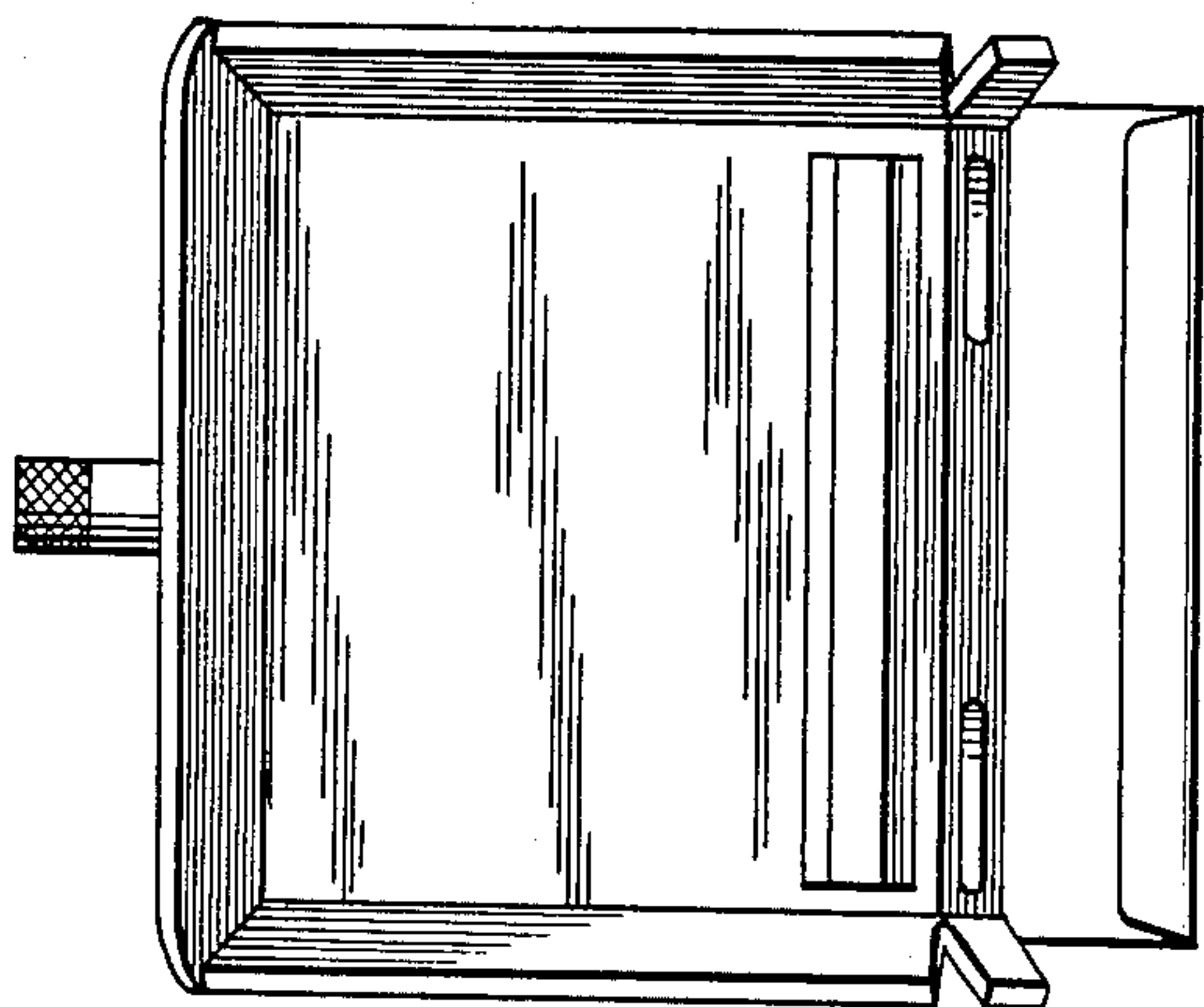

Fig. 10

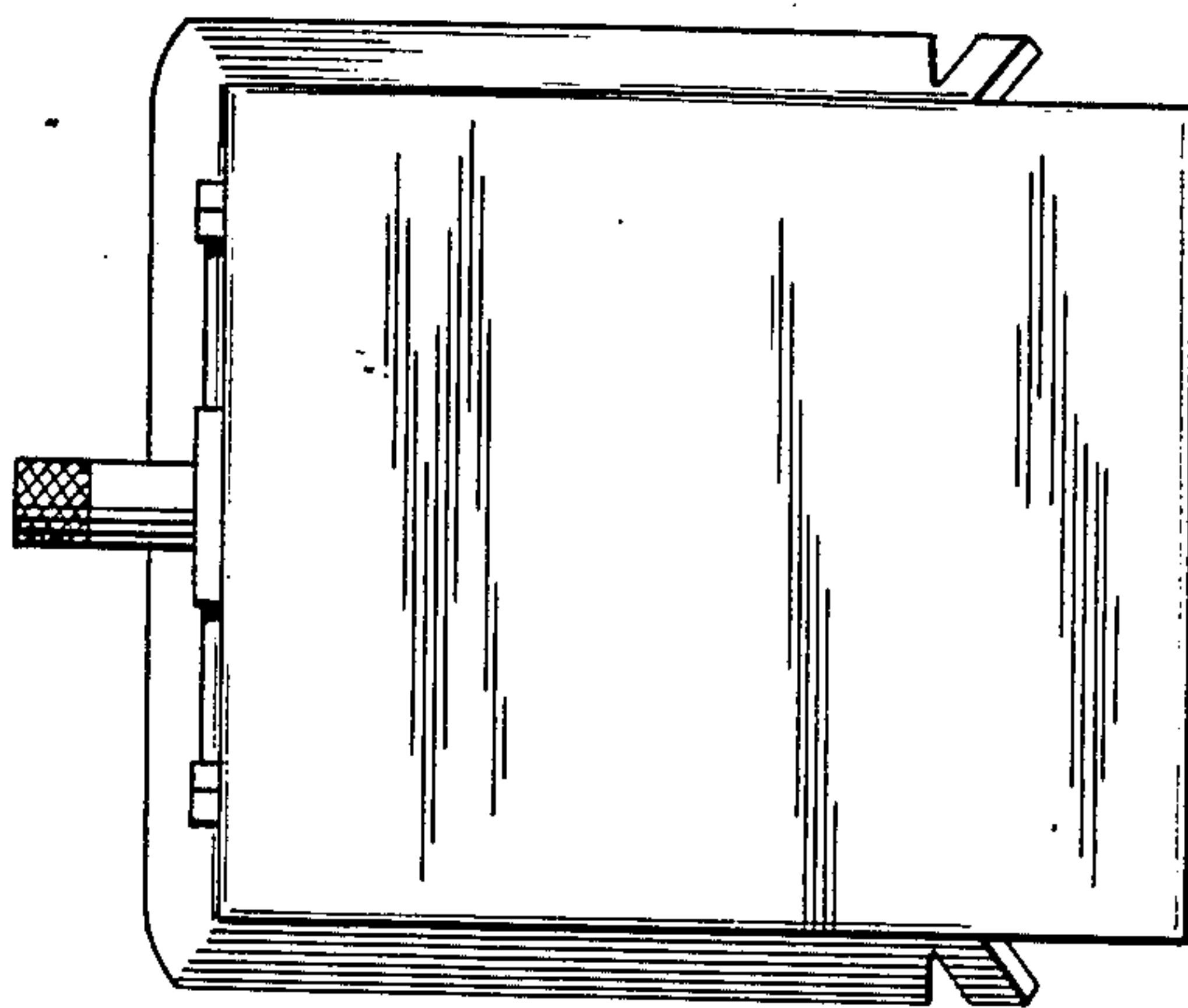

Fig. 11

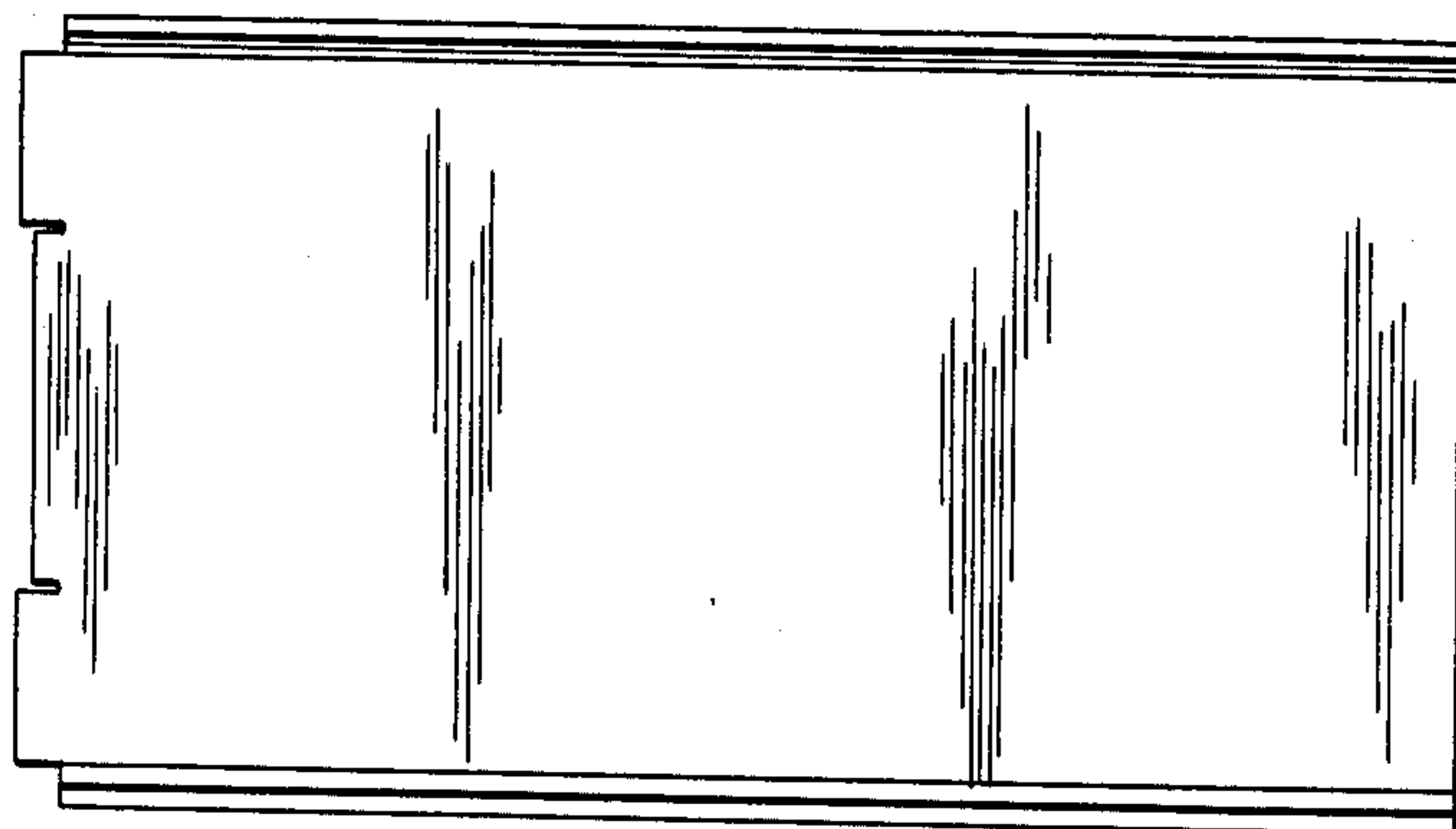

Fig. 12

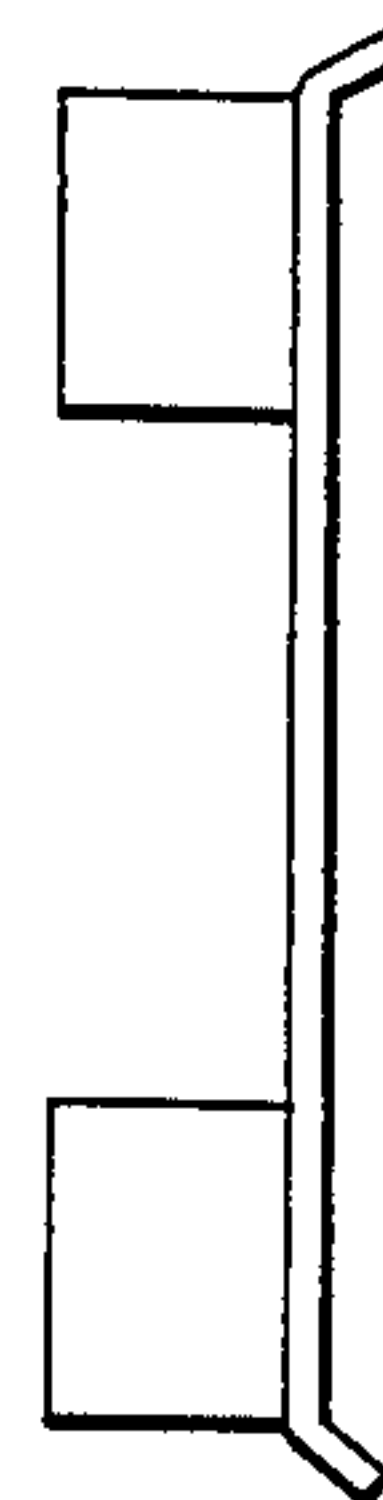
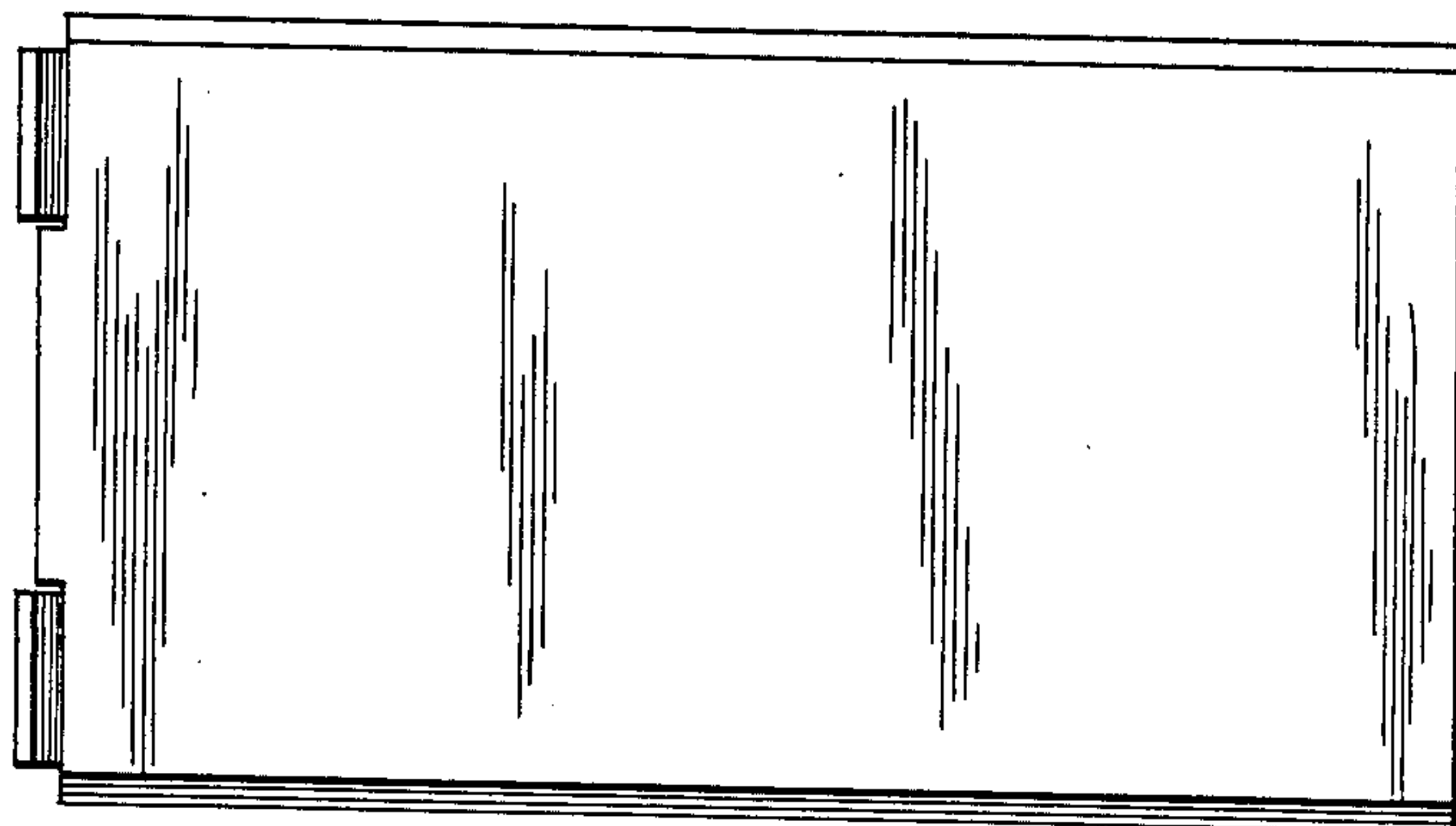
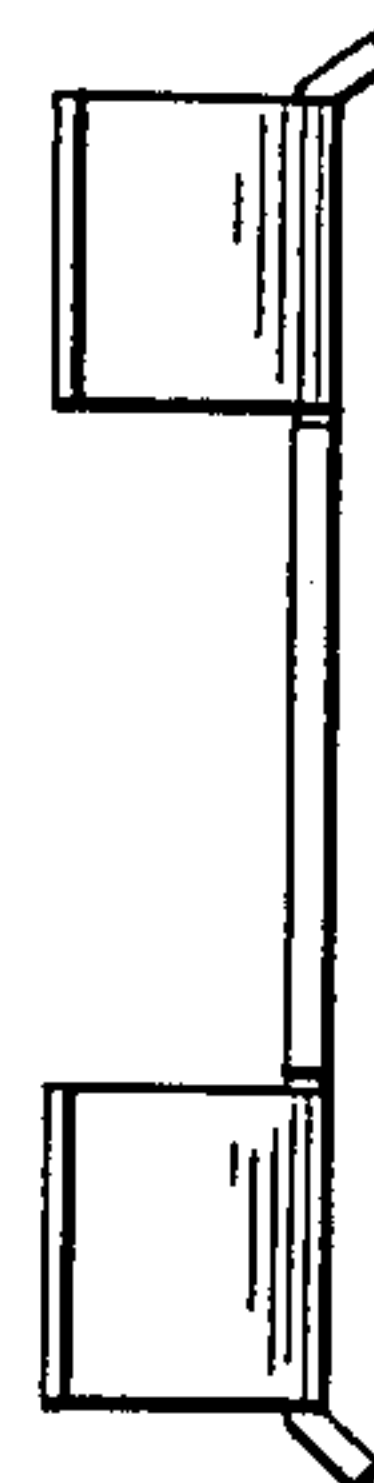

Fig. 13

Fig. 14

FIG. 15

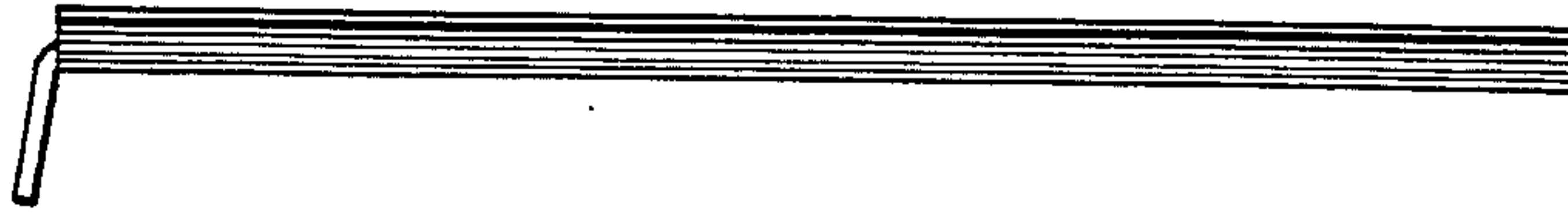

FIG. 16



FIG. 17

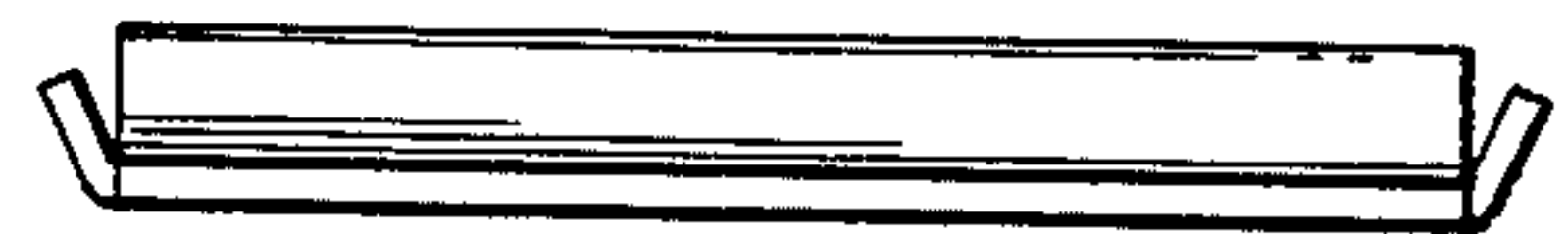
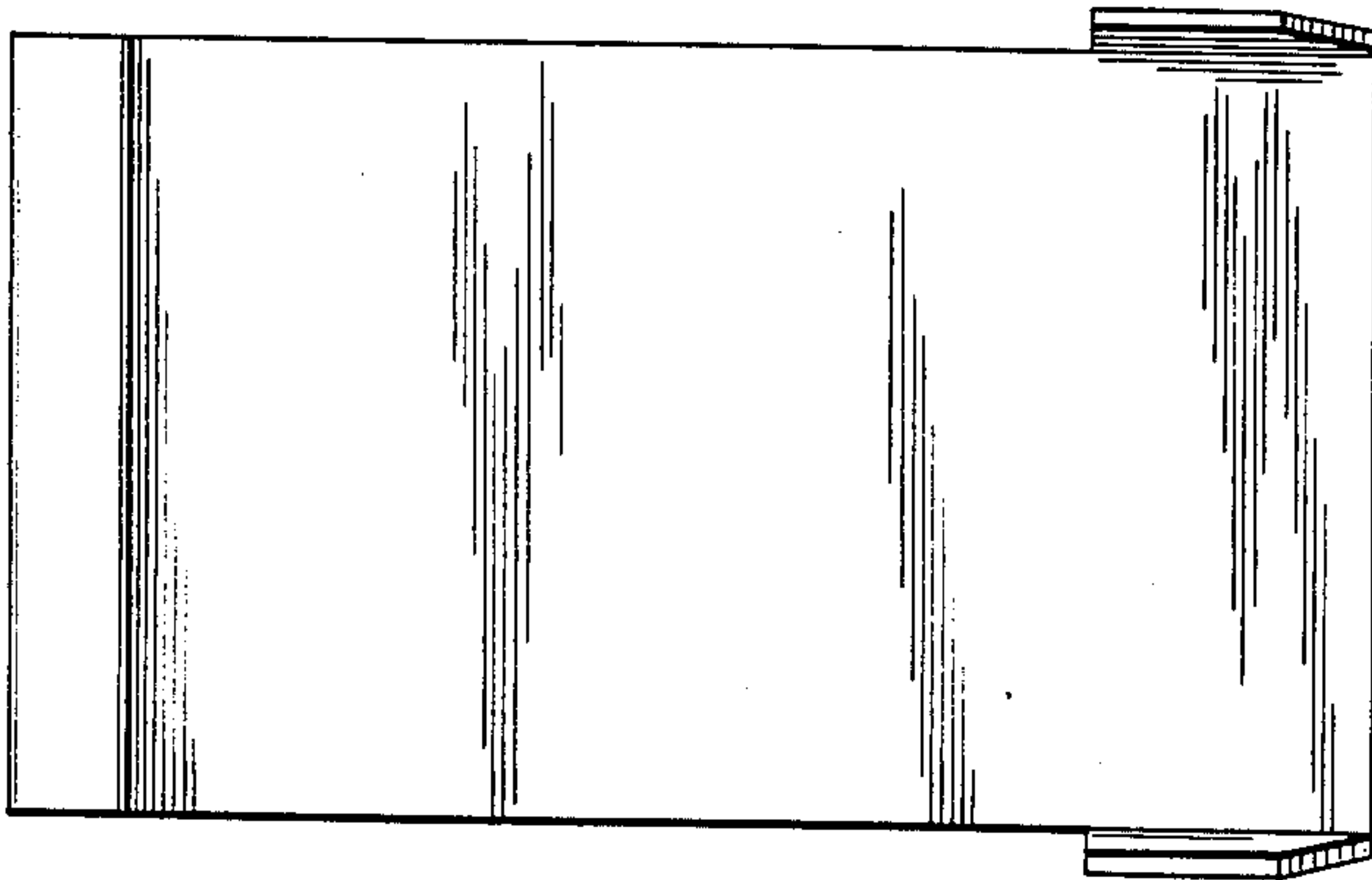

FIG. 19

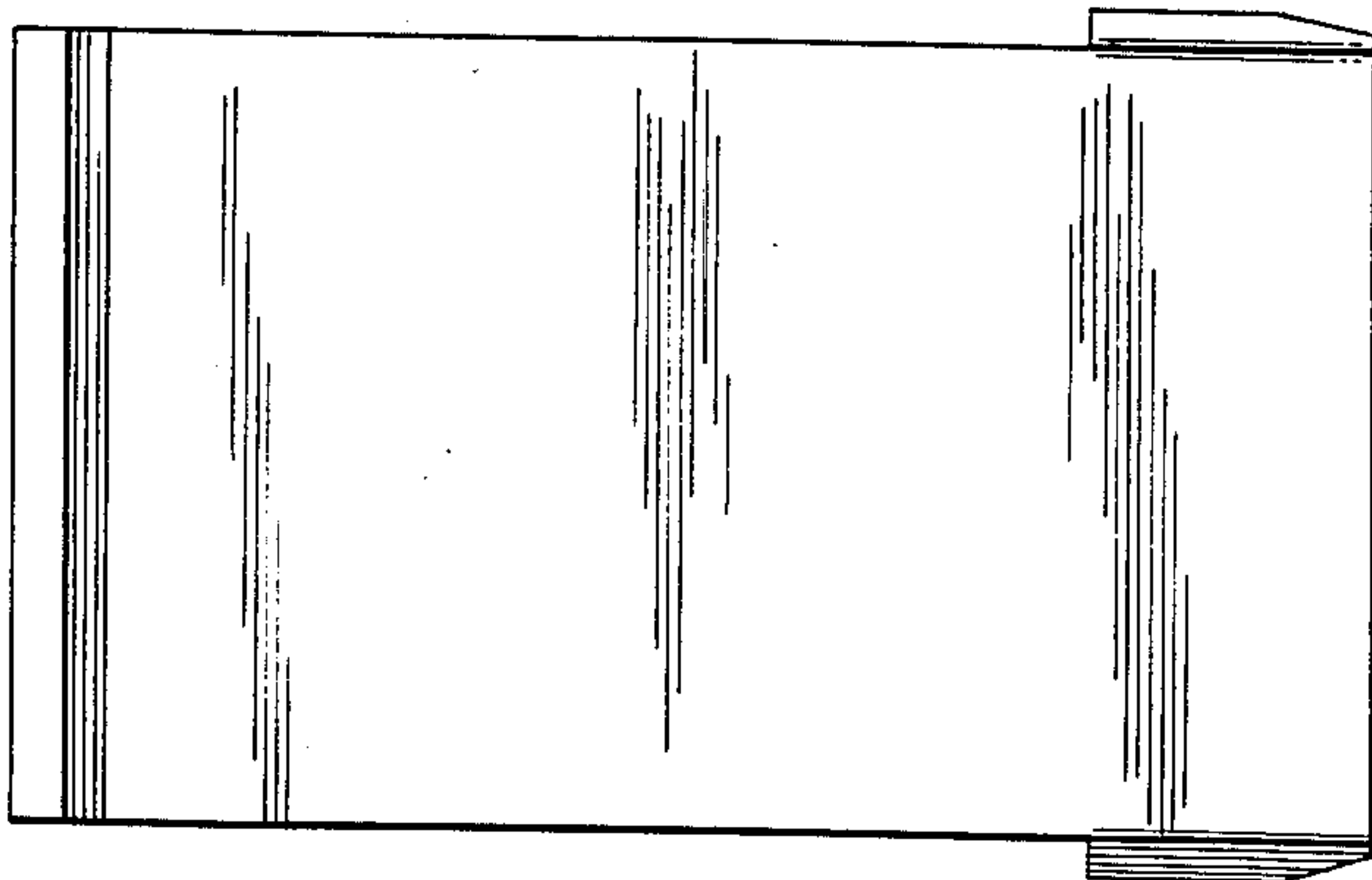

FIG. 20

FIG. 18