

[54] PERCUSSION MUSICAL INSTRUMENT

3,551,580 12/1970 Glenn et al. 84/1.14 X
4,179,974 12/1979 Trankle 84/411 P

[76] Inventors: Richard A. Benson; Peter A. Scott,
both of "Green Hedges" Wrotham
Road, Meopham, Kent, DA13
OHW, England

[**] Term: 14 Years

[21] Appl. No.: 916,859

[22] Filed: Oct. 8, 1986

[30] Foreign Application Priority Data

Aug. 23, 1985 [GB] United Kingdom 1028801

[52] U.S. Cl. D17/22

[58] Field of Search D17/22, 99; 84/411,
84/411 A, 411 M, 411 P, 419, 420, 421

[56] References Cited

U.S. PATENT DOCUMENTS

2,722,860 11/1955 Pace 84/411 P
3,113,480 12/1963 Giarratano 84/422 X
3,186,290 6/1965 Gould et al. 84/411 P

OTHER PUBLICATIONS

Grossman Music Corp. Catalog ©1967, p. 89, bottom
right-Delux Pad.

Primary Examiner—Bernard Ansher
Assistant Examiner—Theodore M. Shooman
Attorney, Agent, or Firm—Banner, Birch, McKie &
Beckett

[57] CLAIM

The ornamental design for percussion musical instru-
ment, as shown.

DESCRIPTION

FIG. 1 is a top, front and right side perspective view of
a percussion musical instrument showing our new de-
sign;

FIG. 2 is a bottom, rear and left side perspective view
thereof; and

FIG. 3 is a sectional view thereof taken along line 3—3
of FIG. 2.

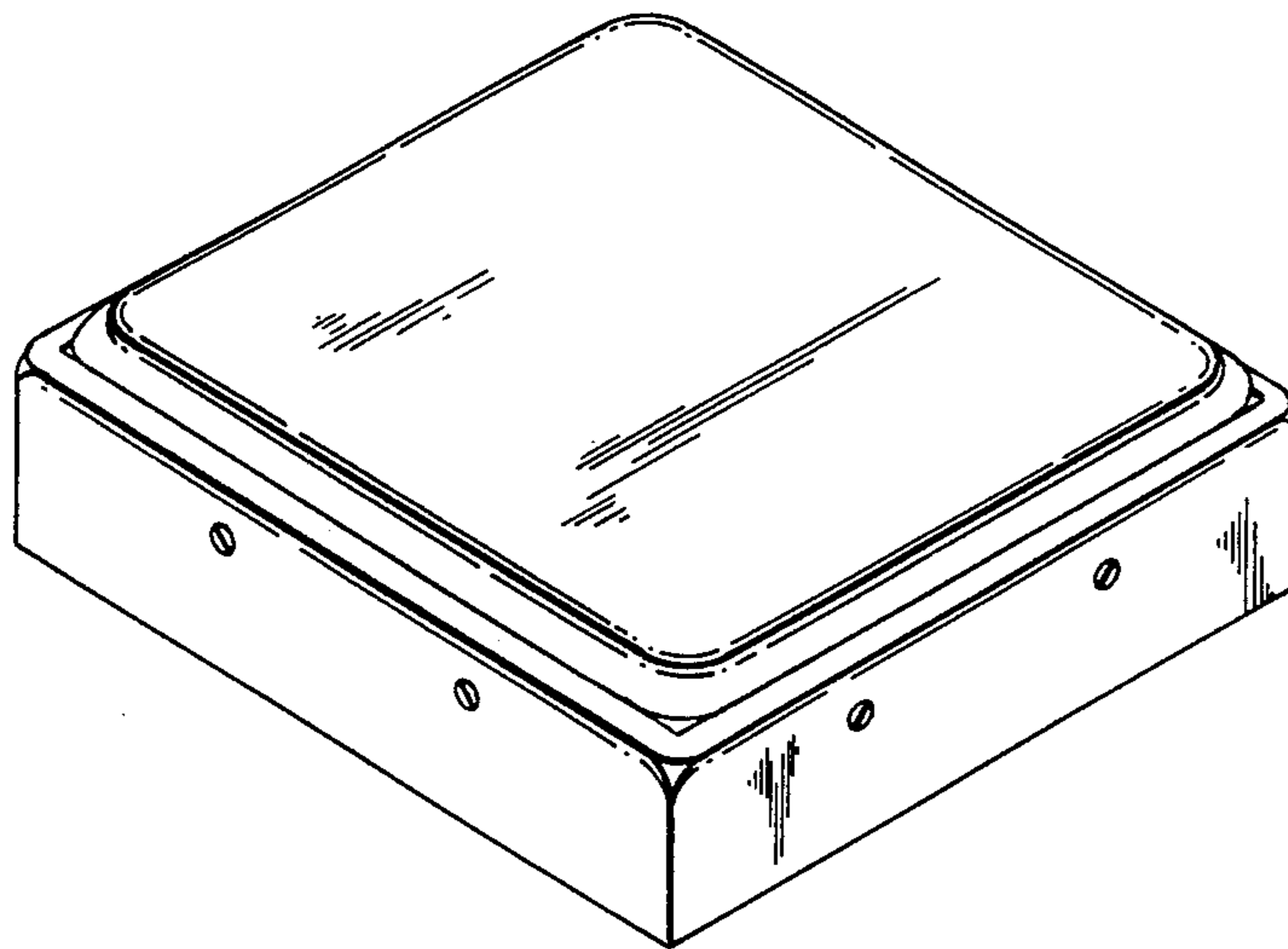

Fig. 1.

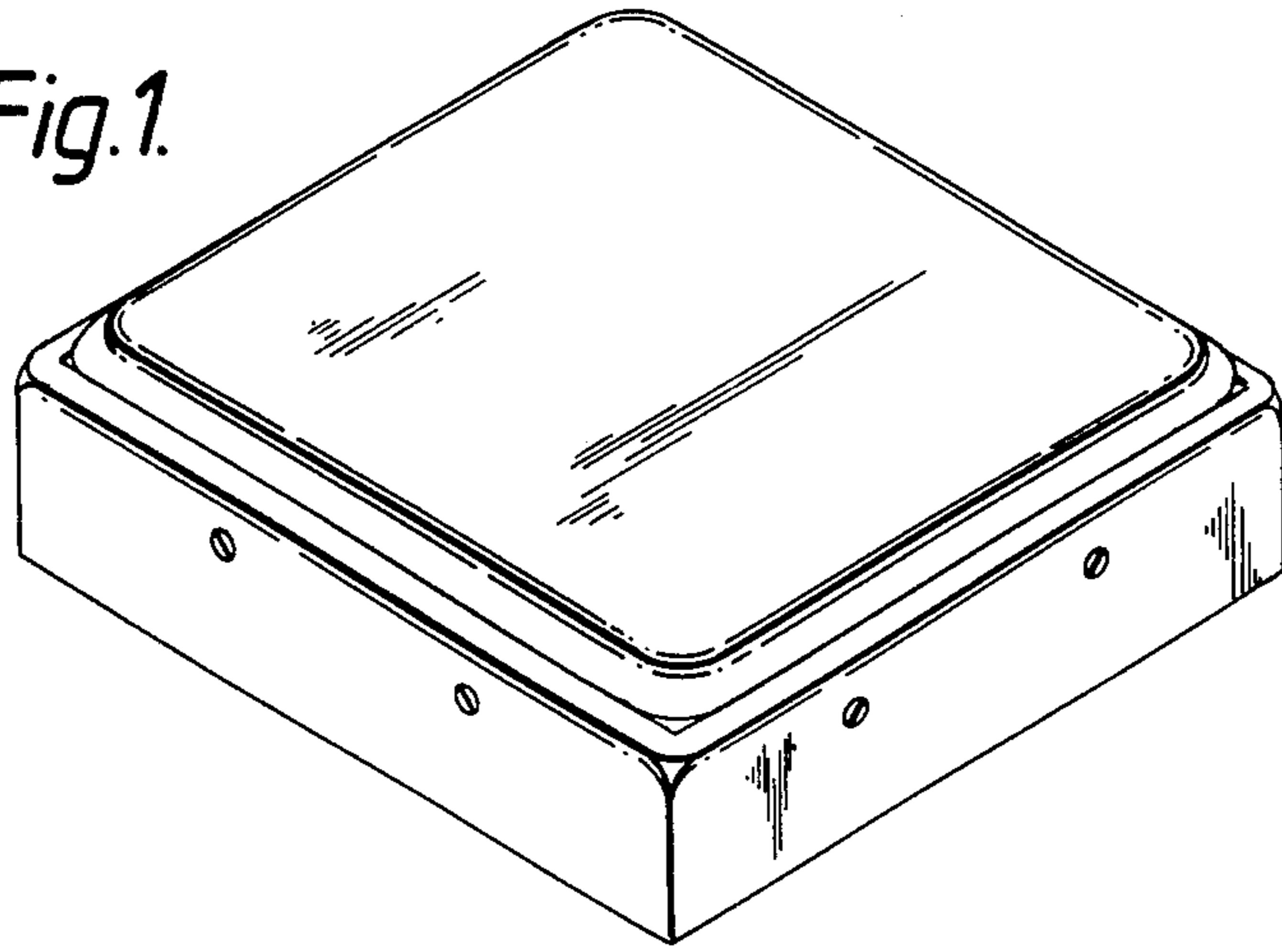

Fig. 2.

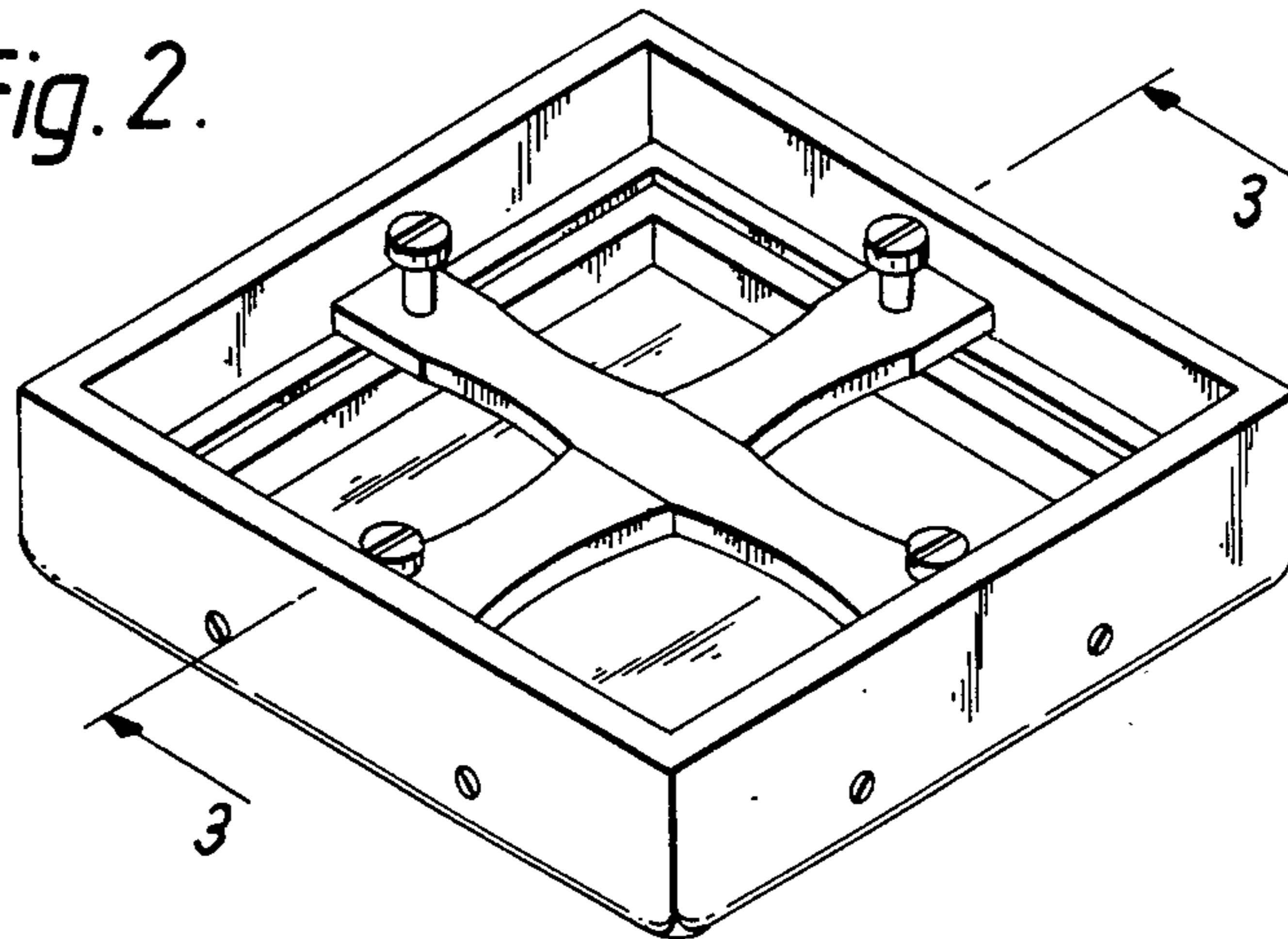

Fig. 3.

