

[54] WATER CRAFT

3,989,002 11/1976 Peterson ..... 114/270

[75] Inventors: Leon Raiter, St. Cloud, Minn.; John Mor, Vernon, Canada; Devlin Hunt, Brainard, Minn.

FOREIGN PATENT DOCUMENTS

940388 1/1974 Canada ..... 114/270  
2172866 10/1986 United Kingdom ..... 114/270

[73] Assignee: Ski-Free Marine, Inc., Calgary, Canada

OTHER PUBLICATIONS

Brochure "Ski-Free Here Comes the Most Revolutionary Machine in Water Ski History", Nov. 1985, by Ski-Free Marine Corporation.

[\*\*] Term: 14 Years

Primary Examiner—Wallace R. Burke  
Assistant Examiner—Kay H. Chin  
Attorney, Agent, or Firm—Vidas & Arrett

[21] Appl. No.: 905,938

[22] Filed: Sep. 10, 1986

[52] U.S. Cl. .... D21/228; D12/307

[58] Field of Search ..... D12/300, 306, 307, 305; 114/56, 289-291, 270; 440/38, 87, 88, 89, 85, 67; D21/236, 228, 229

[57] CLAIM

The ornamental design for a water craft, as shown and described.

[56] References Cited

U.S. PATENT DOCUMENTS

- D. 216,342 12/1969 Lapointe ..... D12/307
- D. 264,698 6/1982 Tindal ..... D12/306
- D. 271,964 12/1983 Judd ..... D12/307
- D. 293,429 12/1987 Franyutti et al. .... D12/307
- 3,339,514 9/1967 Skuce, II ..... D12/307
- 3,608,612 9/1971 Thompson ..... D21/228
- 3,828,717 8/1974 Nichols et al. .... 440/85
- 3,842,786 10/1974 Uroshevich ..... 440/67

DESCRIPTION

FIG. 1 is a left side perspective view of a water craft showing our new design;  
FIG. 2 is a right side perspective view thereof;  
FIG. 3 is a front perspective view thereof;  
FIG. 4 is a rear perspective view thereof;  
FIG. 5 is a top perspective view thereof; and  
FIG. 6 is a bottom plan view thereof.

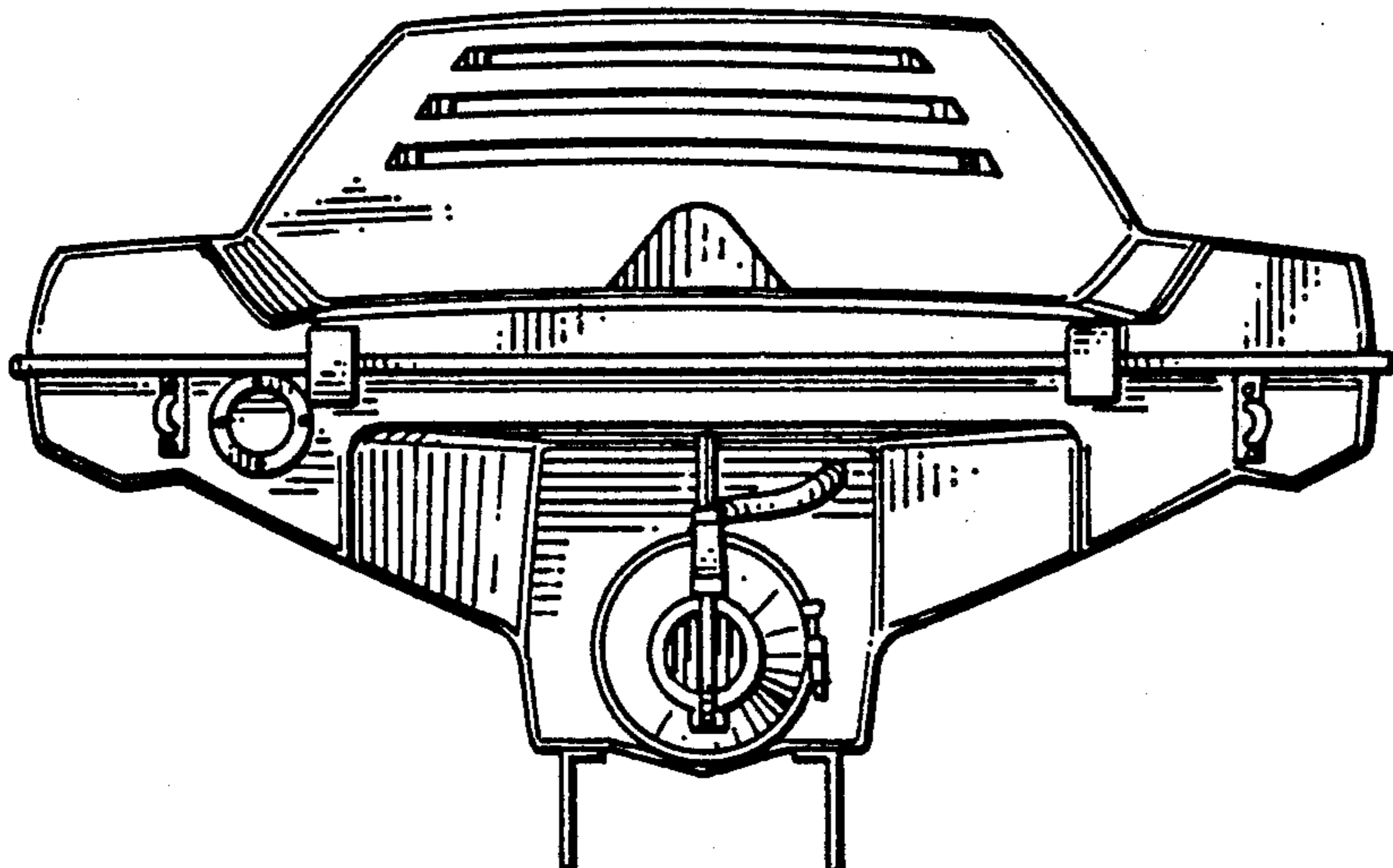
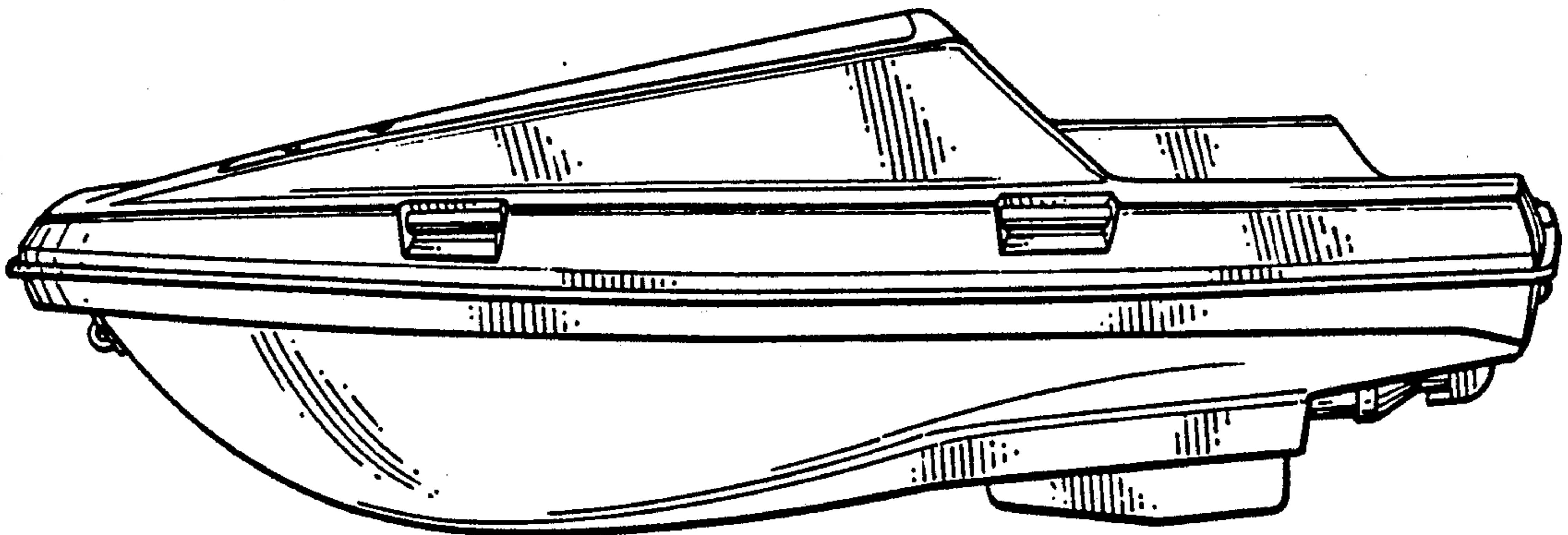

**Fig. 1**

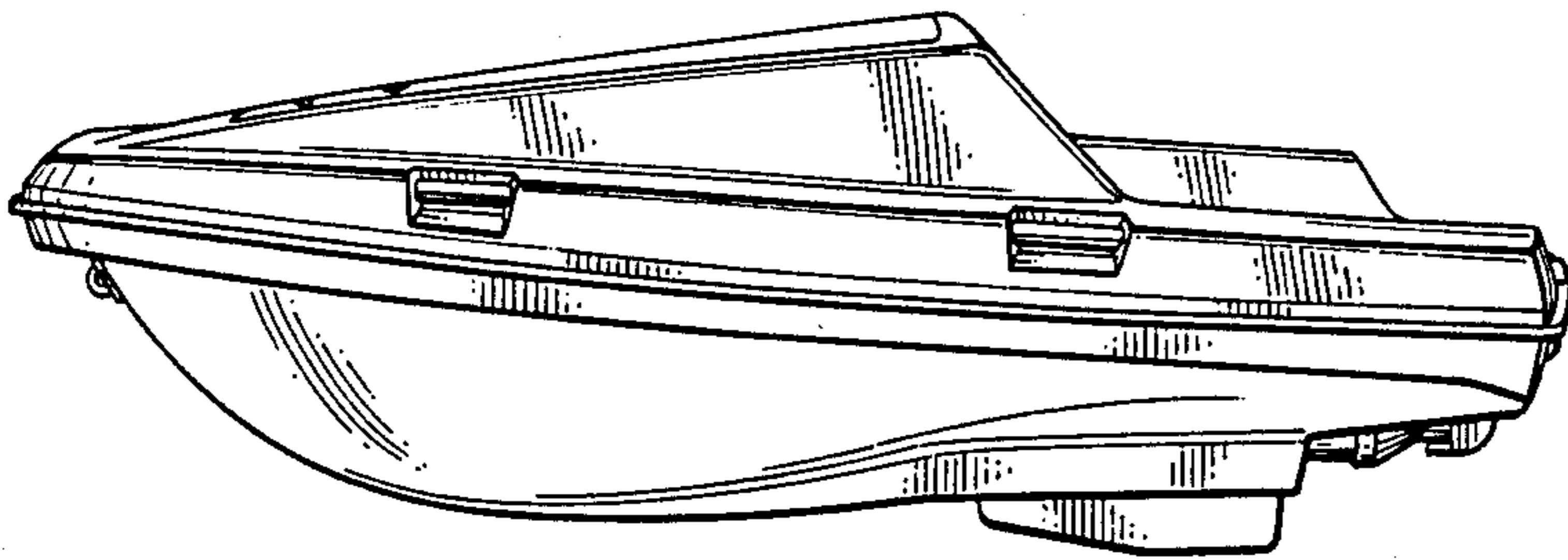

**Fig. 2**

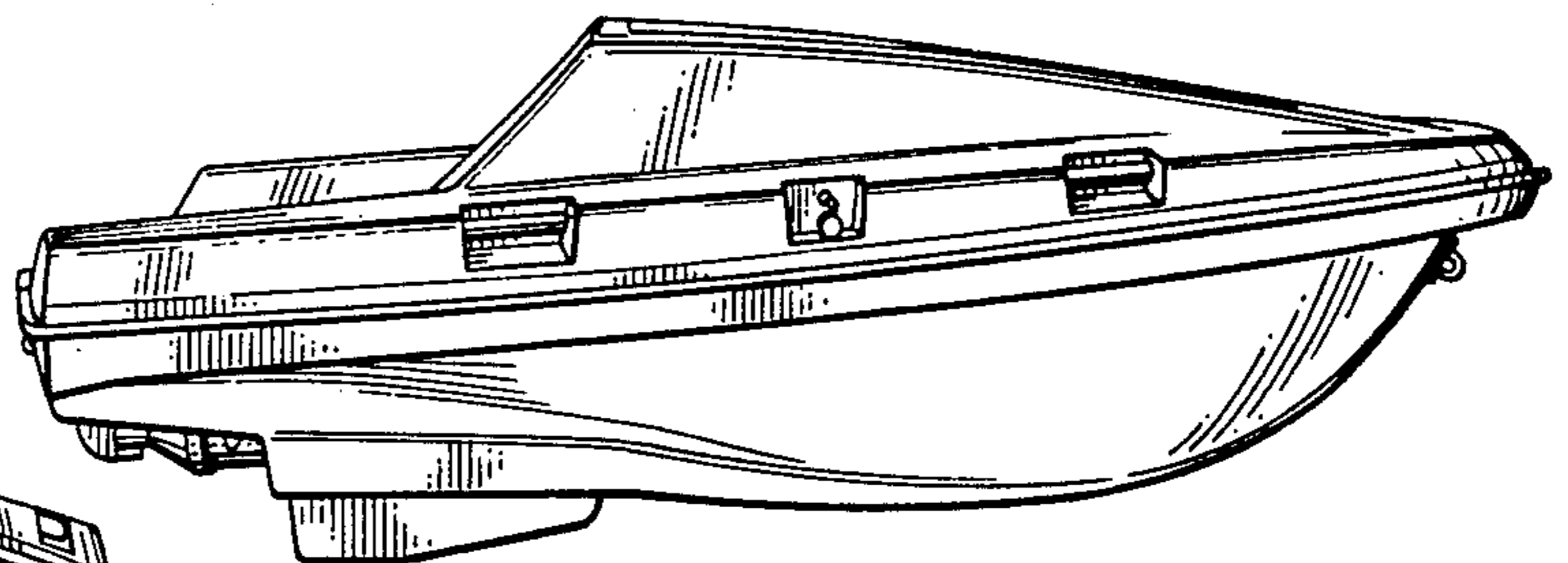

**Fig. 3**

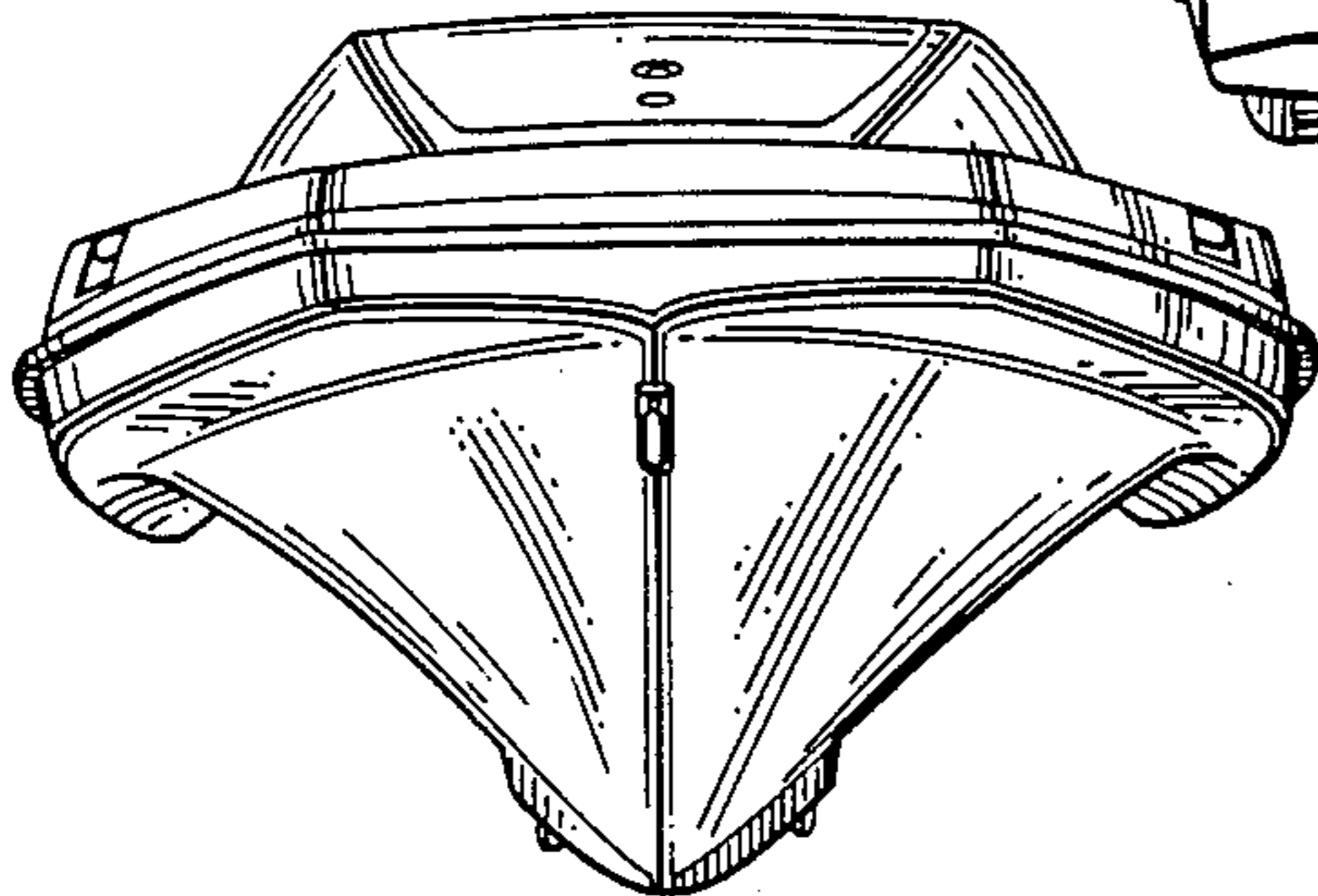

**Fig. 4**

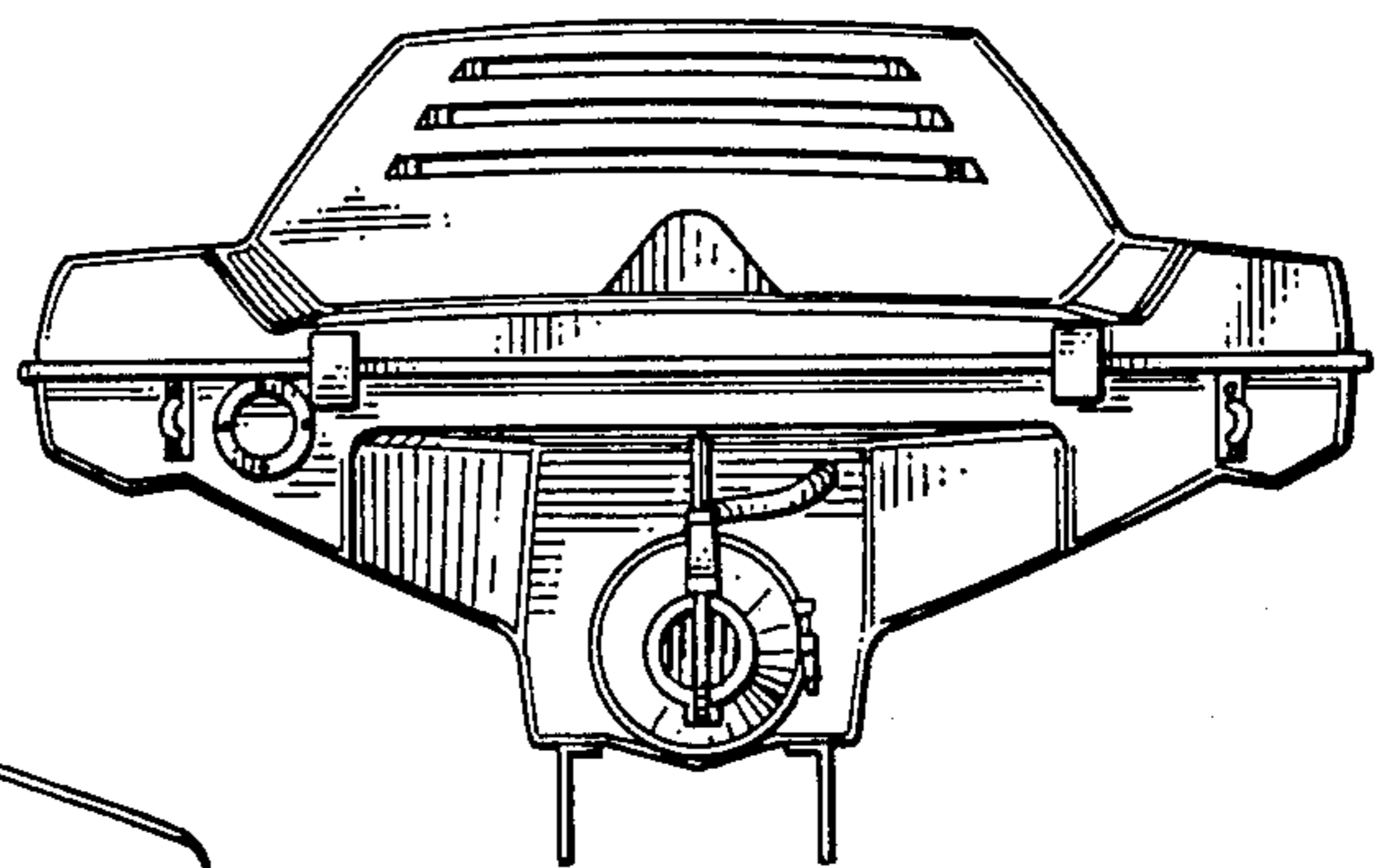

**Fig. 6**

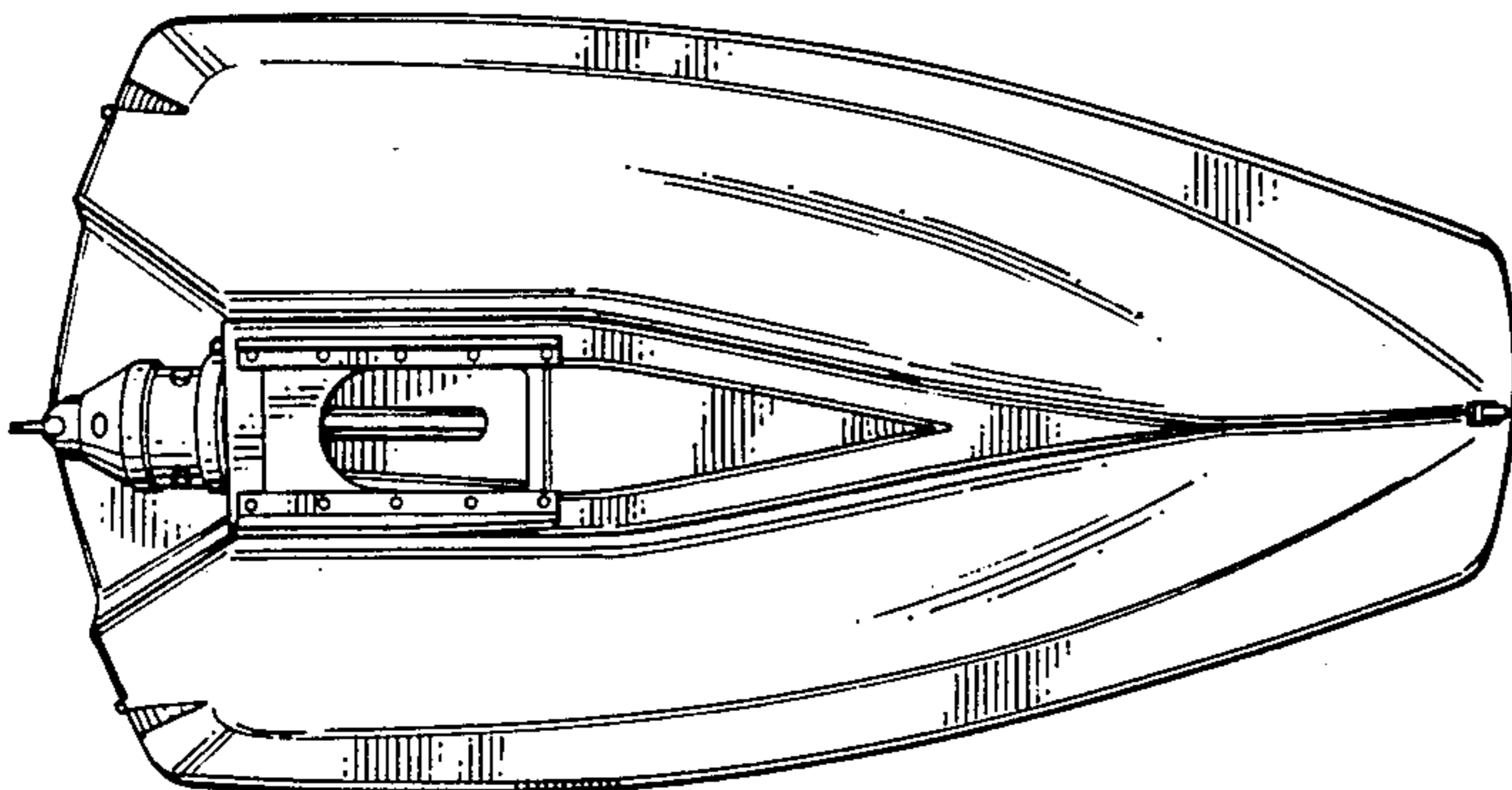

**Fig. 5**

