

[54] **ROBOTIC ARM**

[75] **Inventor: Timothy J. Jones, London, England**

[73] **Assignee: Universal Machine Intelligence Limited, London, England**

[**] **Term: 14 Years**

[21] **Appl. No.: 758,799**

[22] **Filed: Jul. 25, 1985**

[30] **Foreign Application Priority Data**

May 10, 1985 [GB] United Kingdom 1026718
[52] **U.S. Cl. D15/199; D15/122**
[58] **Field of Search D15/122, 199; 414/729, 414/730, 732, 737, 738, 739, 740, 741, 744 R, 744 A, 744 B, 744 C; 901/14-16**

[56] **References Cited**

U.S. PATENT DOCUMENTS

D. 274,182 6/1984 Kato D15/199
D. 279,571 7/1985 Arai et al. D15/122
D. 280,203 8/1985 Shibayama et al. D15/122
3,476,266 11/1969 Devol 414/739
3,883,009 5/1975 Swoboda et al. 414/740
4,594,049 6/1986 Terauchi 414/744 R

Primary Examiner—B. J. Bullock
Attorney, Agent, or Firm—Watson, Cole, Grindle & Watson

[57] **CLAIM**

The ornamental design for a robotic arm, substantially as shown and described.

DESCRIPTION

FIG. 1 is a left side view showing my new design;
FIG. 2 is a front view;
FIG. 3 is a rear view;
FIG. 4 is a right side view; and
FIG. 5 is a top view.

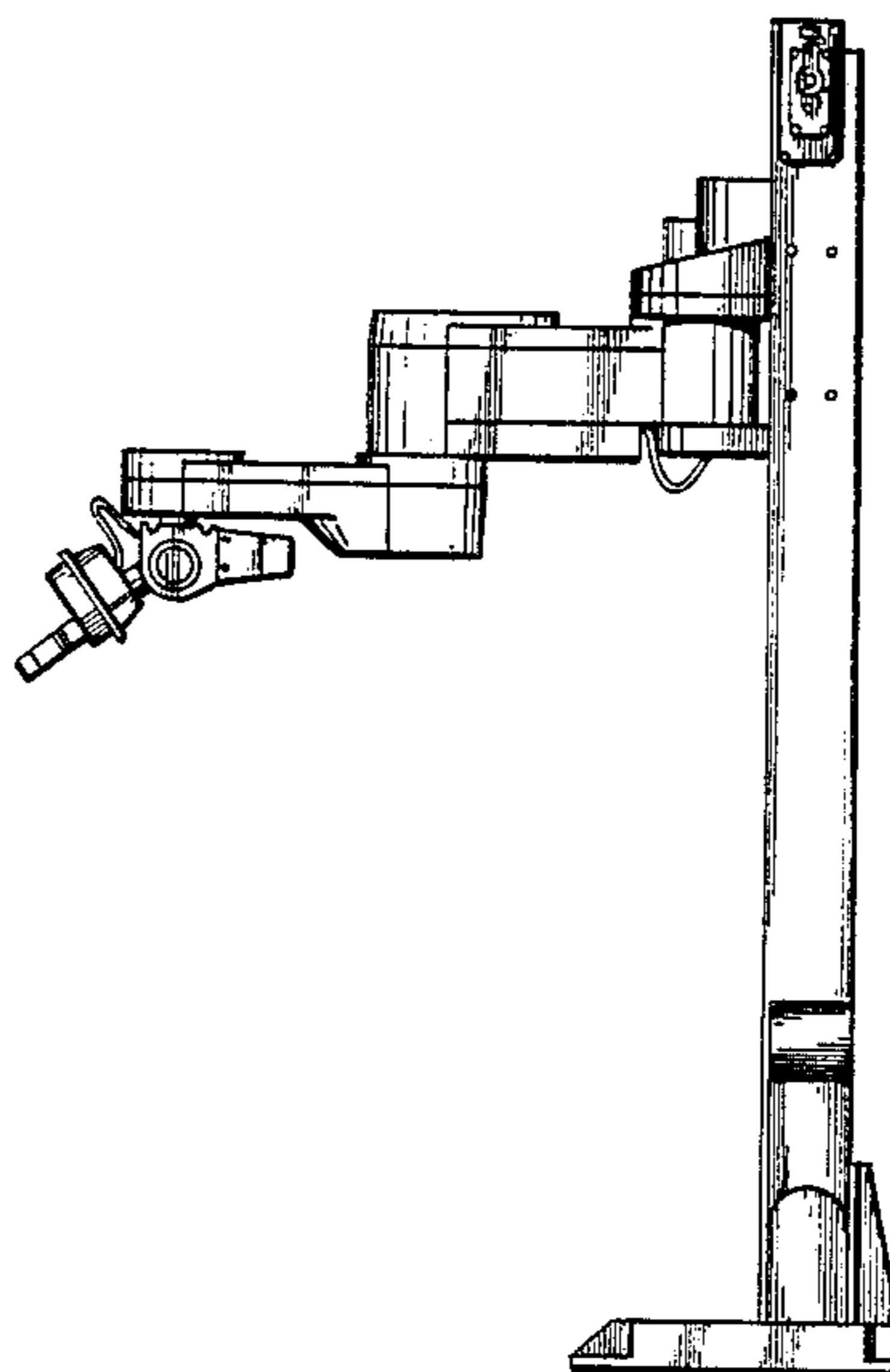
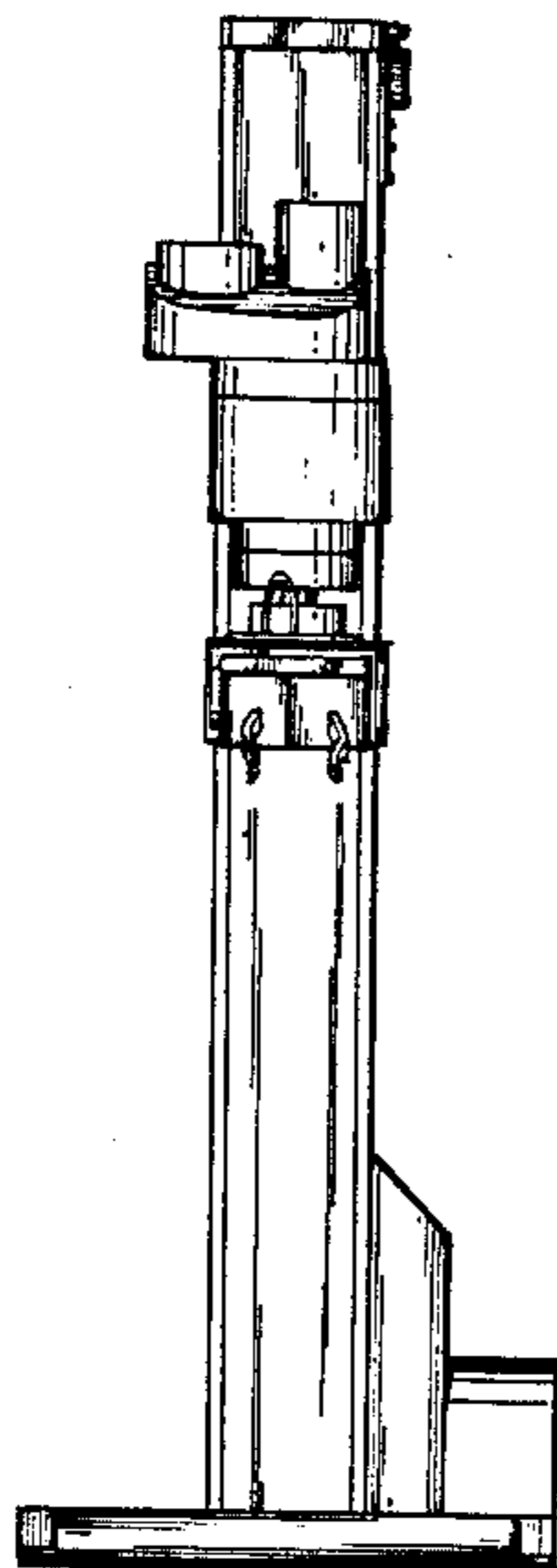

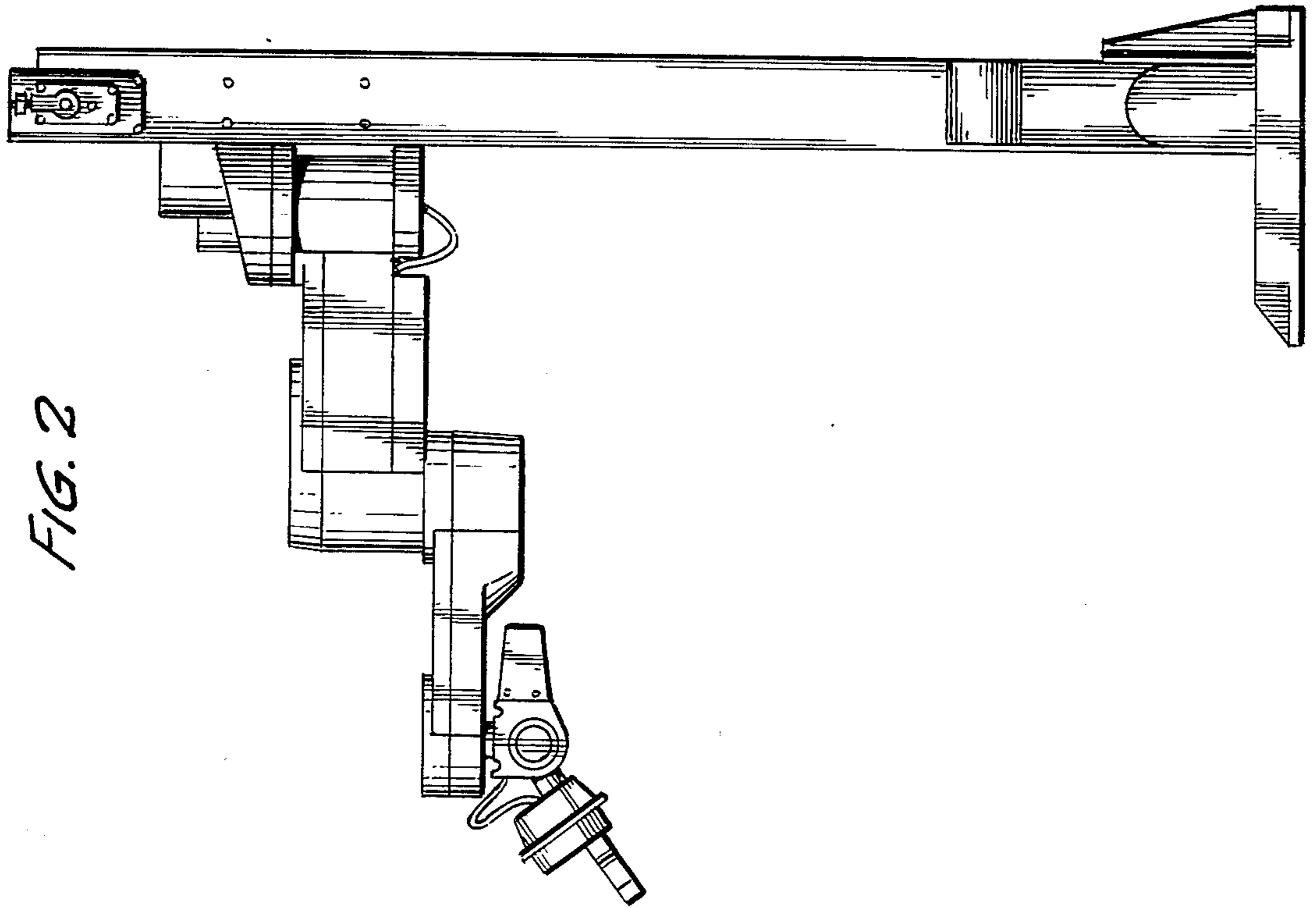

FIG. 2

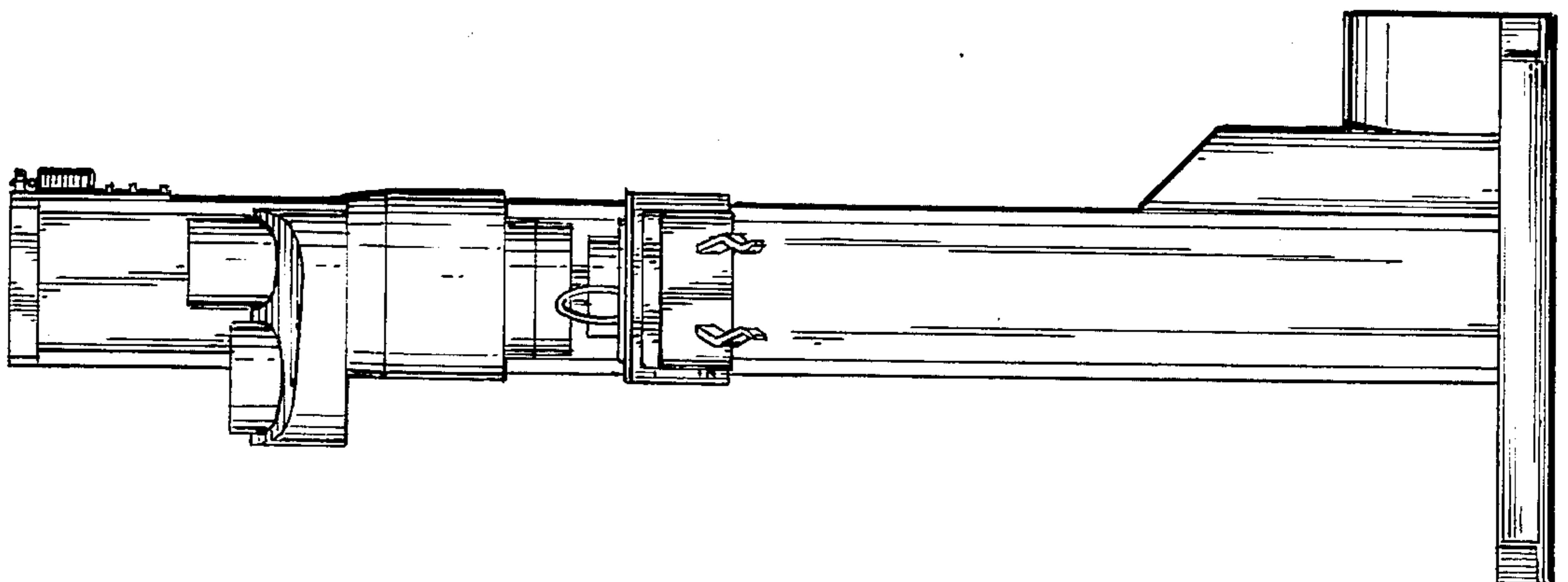

FIG. 1

FIG. 4

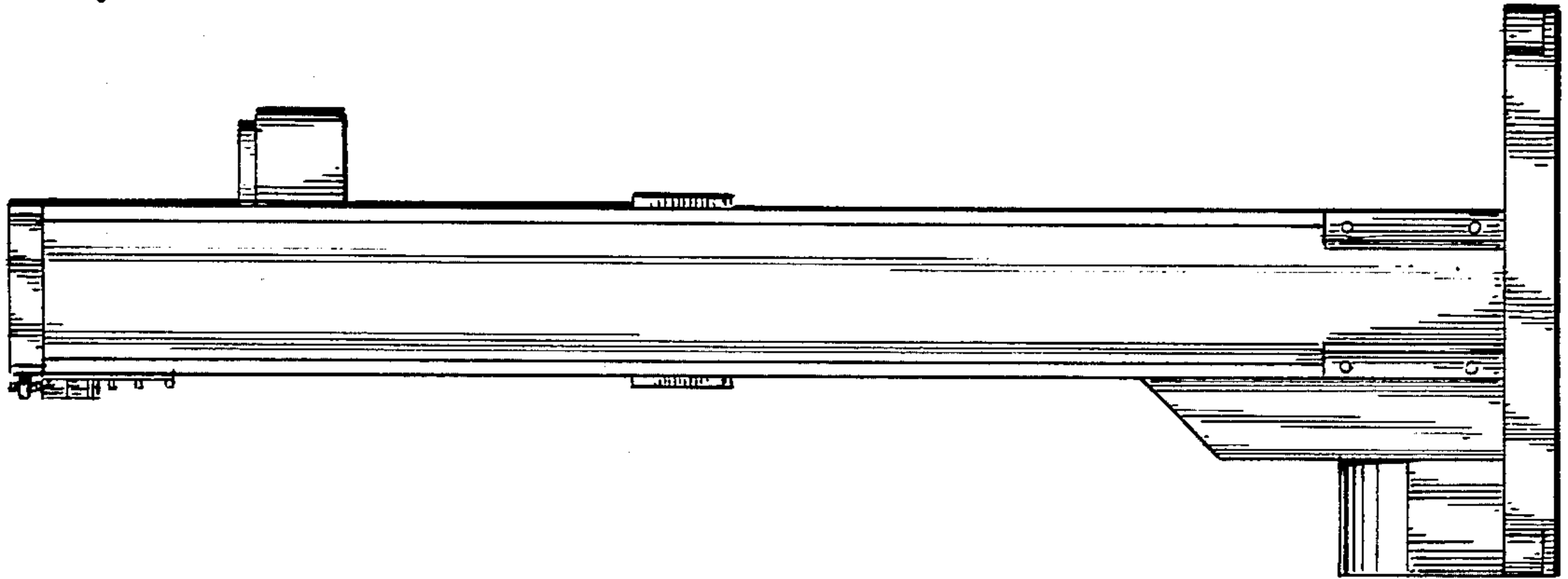

FIG. 3

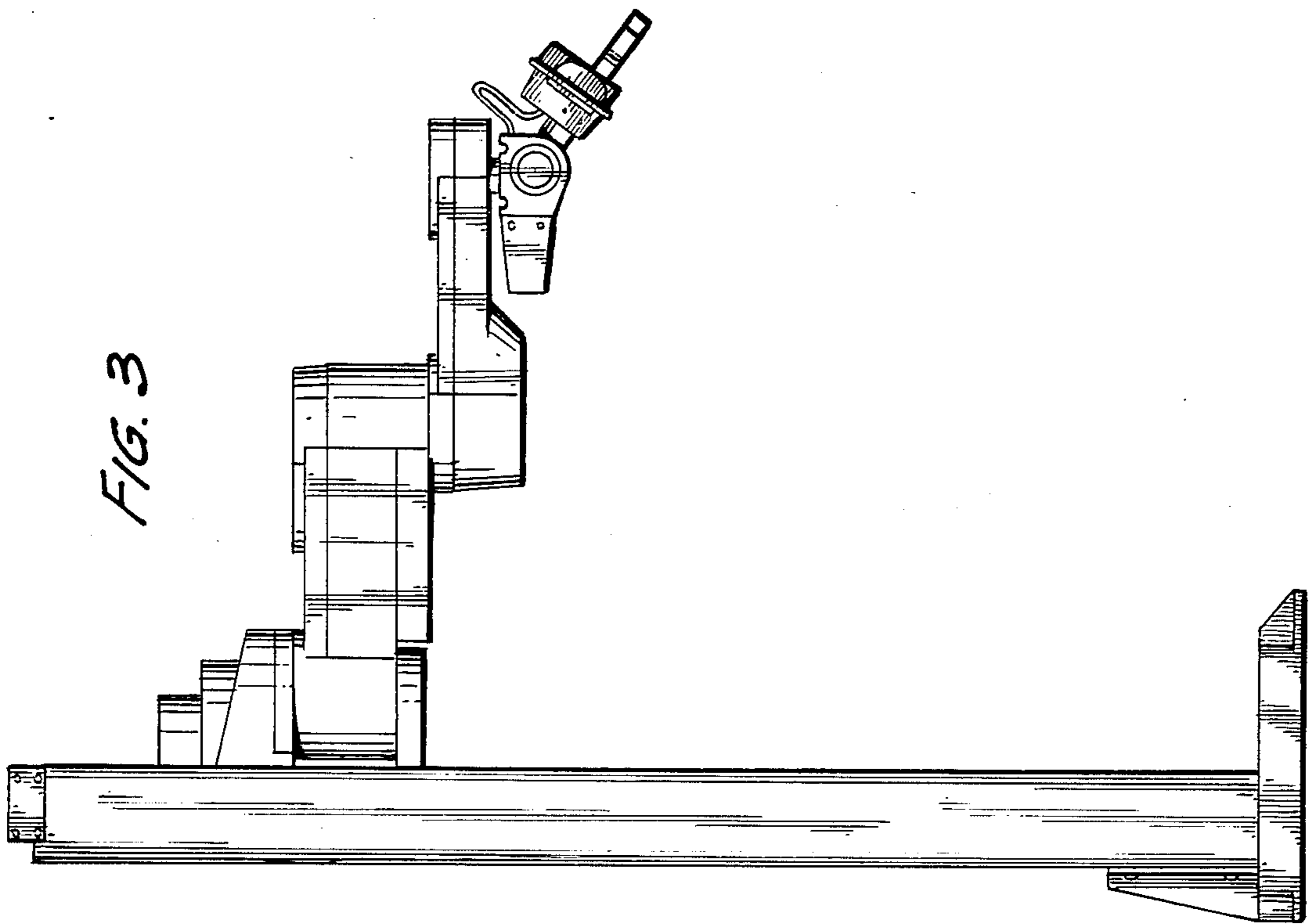

FIG. 5

