

[54] LIFT TRUCK BODY

[75] Inventors: Warner K. Brown; Robert L. Kirby, both of Battle Creek, Mich.; Dennis M. Lanci, Renton, Wash.; Jay J. Reinhart, Battle Creek, Mich.

[73] Assignee: Clark Equipment Company, South Bend, Ind.

[**] Term: 14 Years

[21] Appl. No.: 745,553

[22] Filed: Jun. 17, 1985

[52] U.S. Cl. D34/37

[58] Field of Search D34/28, 34, 37; D12/14; 180/89.14, 89.17, 89.18; D15/30, 22, 23, 24, 26; 187/9 R; 296/190

[56] References Cited

U.S. PATENT DOCUMENTS

D. 240,294	6/1976	De Priester	D34/37
D. 257,432	10/1980	Erlacher	D34/34
D. 271,720	12/1983	Brown et al.	D34/37
D. 272,956	3/1984	Kirby et al.	D34/37
D. 276,757	12/1984	Haswell	D34/34
3,992,042	11/1976	Helmick et al.	D15/26
4,120,375	10/1978	Shinoda et al.	180/89.14

Primary Examiner—James M. Gandy
Assistant Examiner—Kay H. Chin
Attorney, Agent, or Firm—John C. Wiessler

[57] CLAIM

The ornamental design for a lift truck body, substantially as shown and described.

DESCRIPTION

FIG. 1 is a front perspective view of a lift truck body showing our new design;
FIG. 2 is a right side elevational view thereof;
FIG. 3 is a left side elevational view thereof;
FIG. 4 is a front elevational view thereof;
FIG. 5 is a rear elevational view thereof;
FIG. 6 is a top plan view thereof;
FIG. 7 is a rear perspective view thereof;
FIG. 8 is a front perspective view of a lift truck body showing a second embodiment;
FIG. 9 is a right side elevational view of FIG. 8;
FIG. 10 is a left side elevational view of FIG. 8;
FIG. 11 is a front elevational view of FIG. 8;
FIG. 12 is a rear elevational view of FIG. 8;
FIG. 13 is a top plan view of FIG. 8;
FIG. 14 is a rear perspective view of FIG. 8.
The broken lines shown in FIGS. 1 through 15 are for illustrative purposes only and form no part of the claimed design

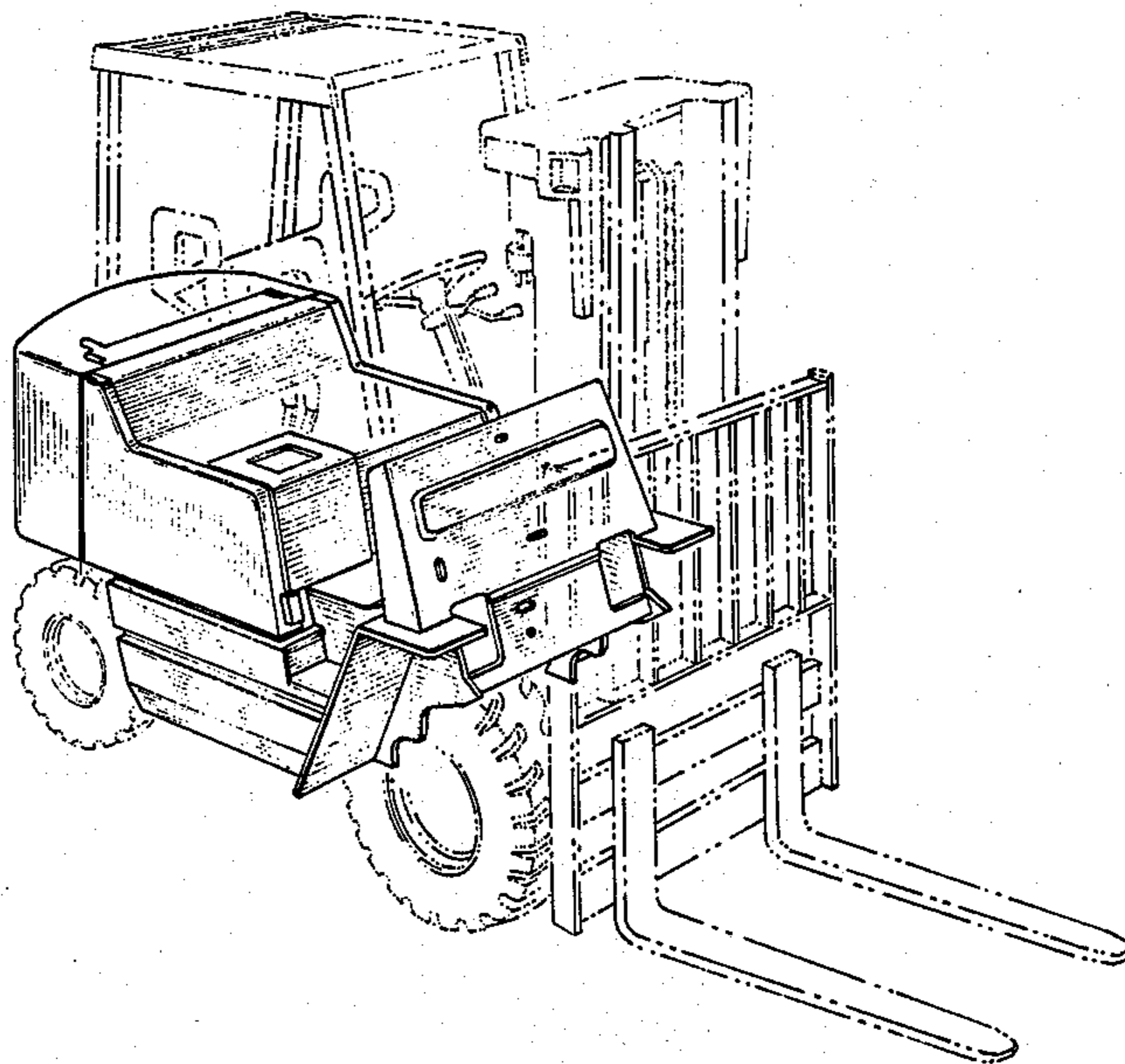

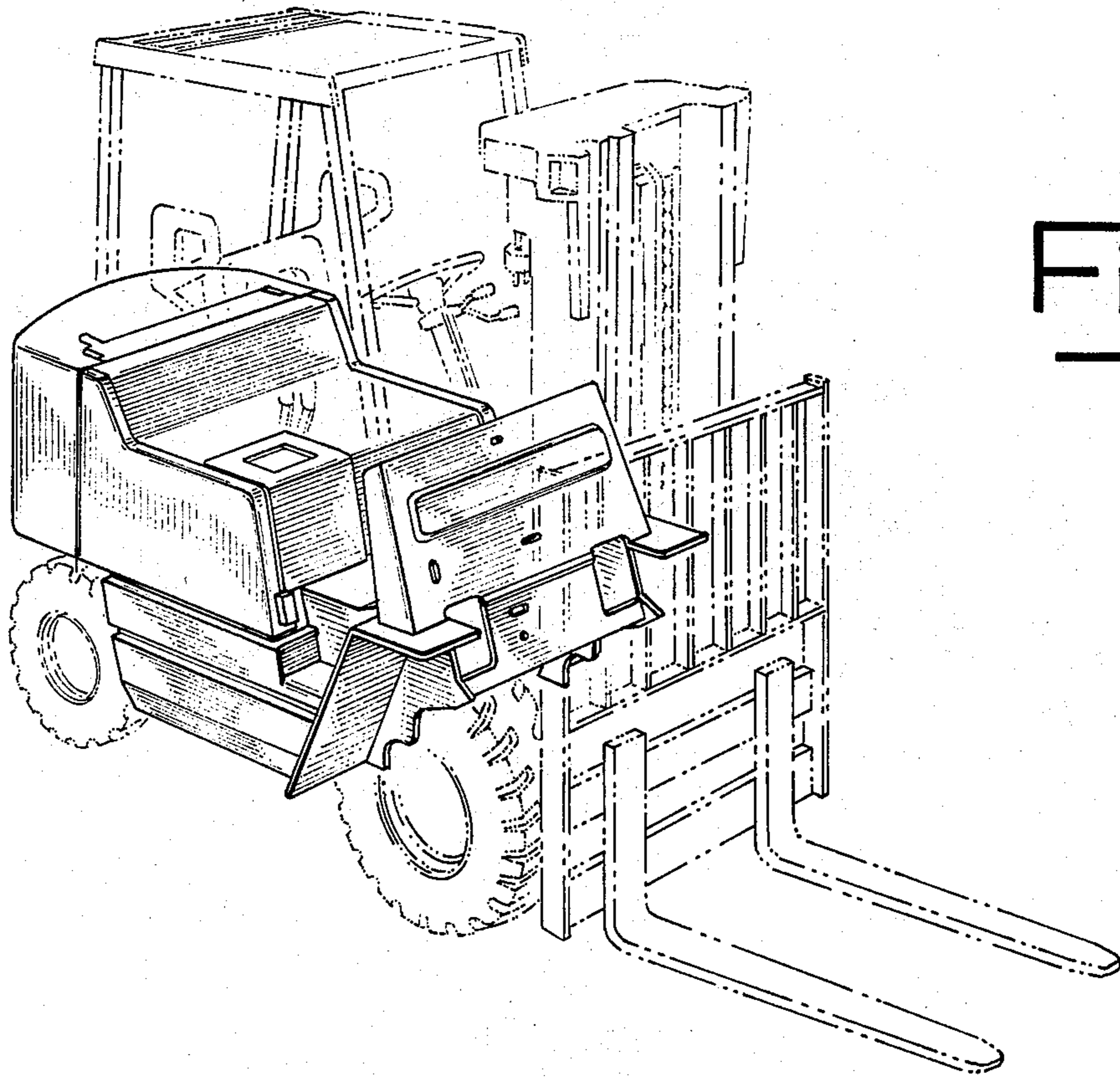

Fig. 1

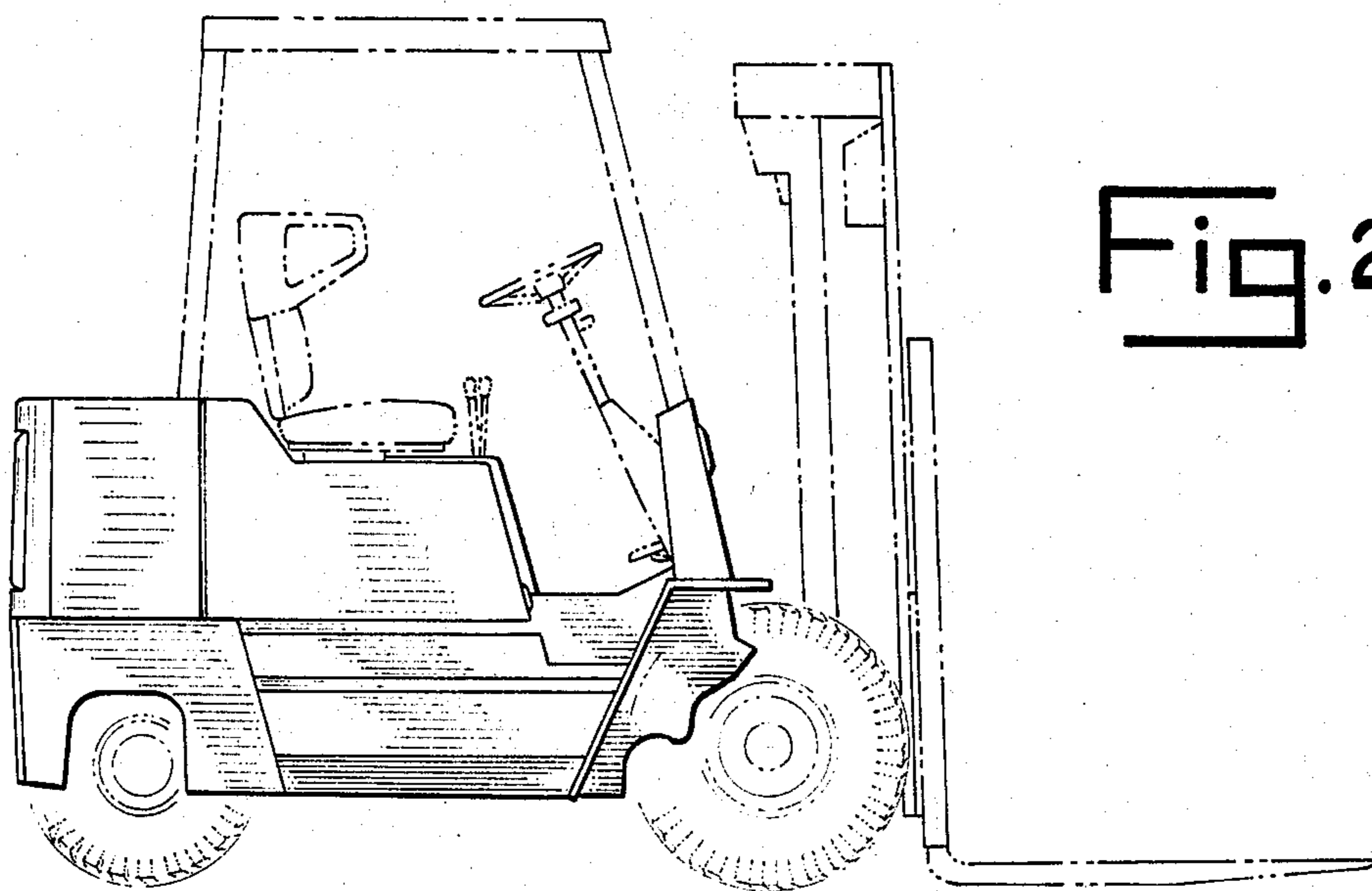

Fig. 2

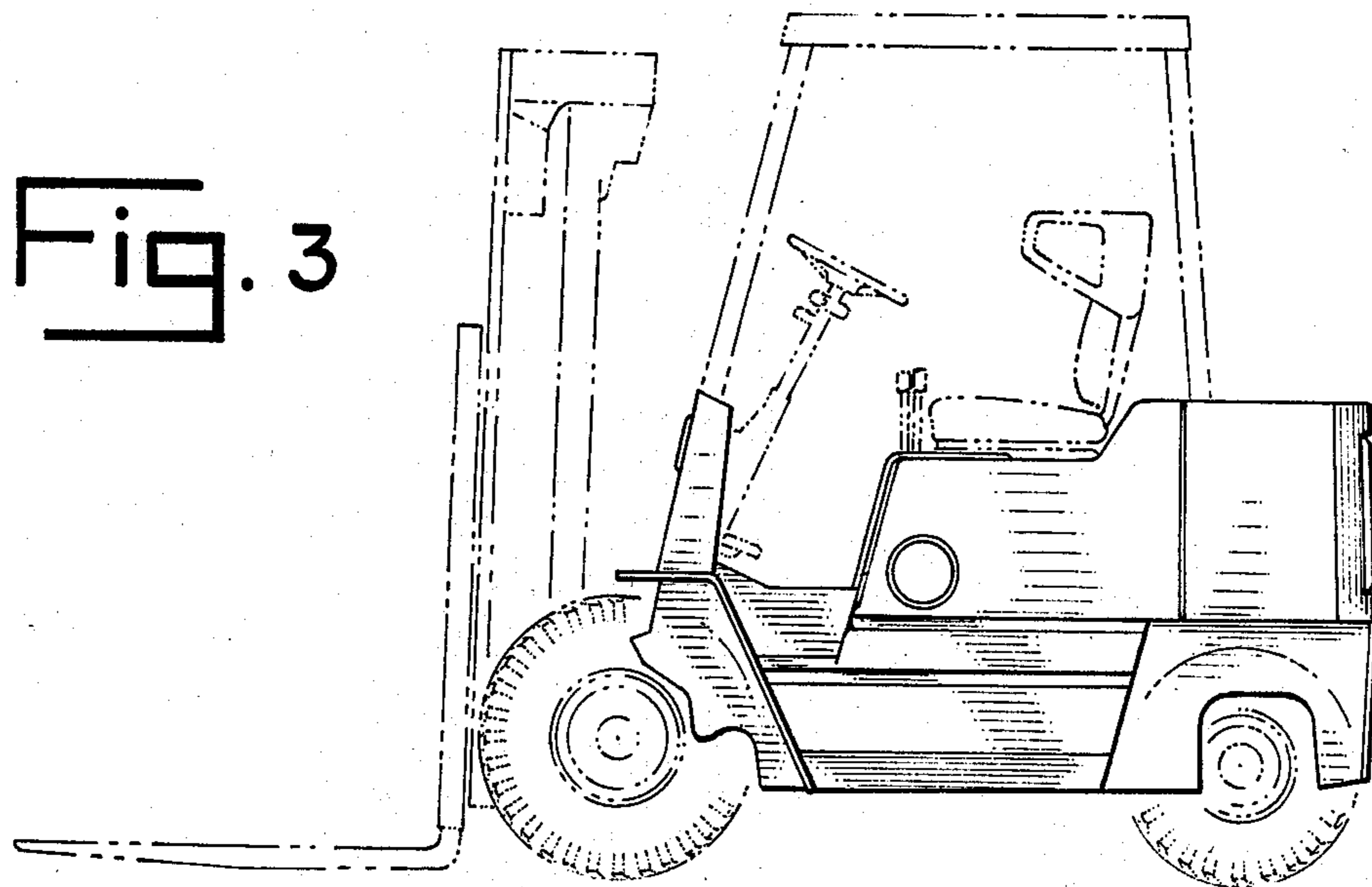

Fig. 4

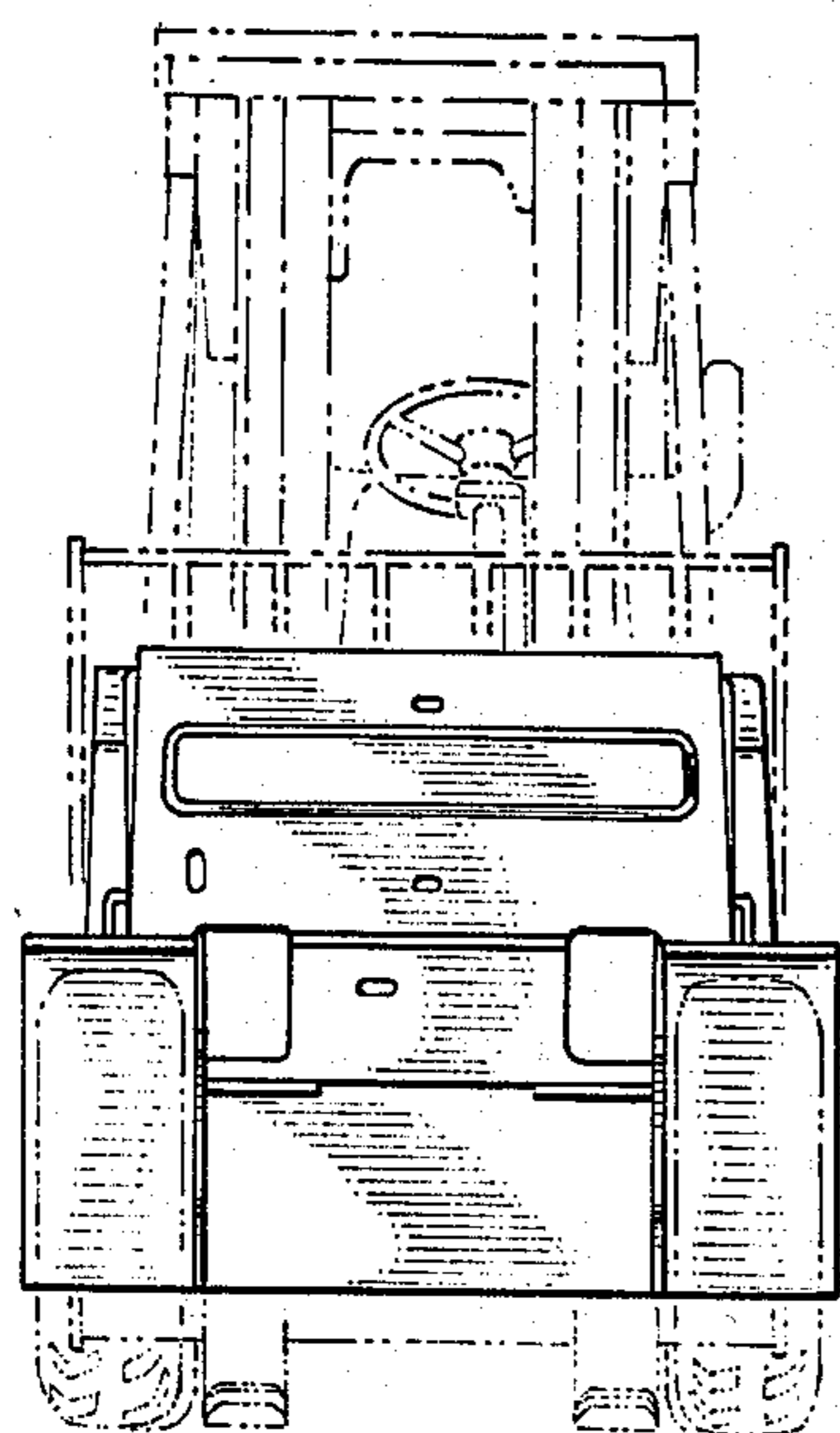

Fig. 5

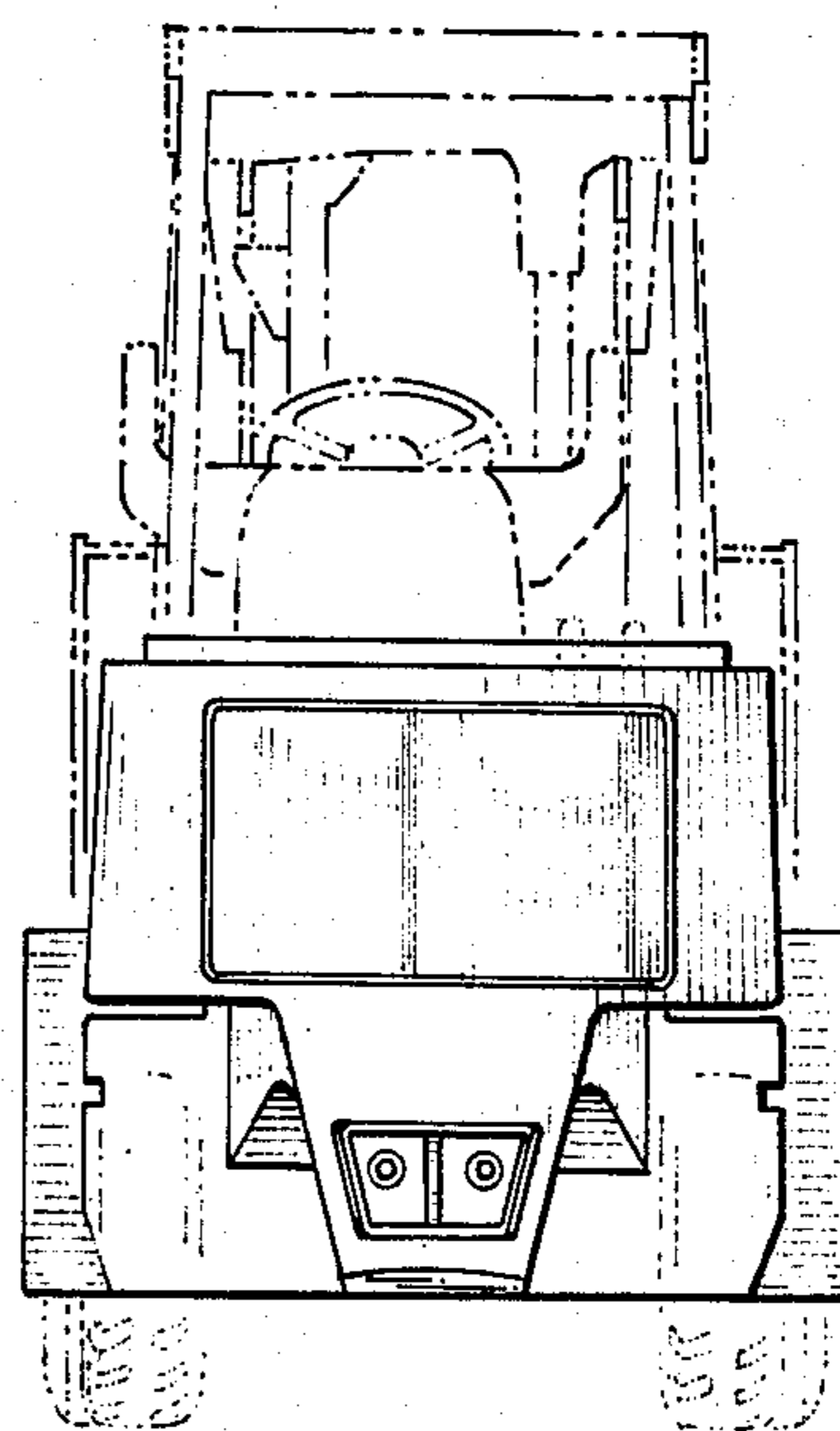

Fig. 6

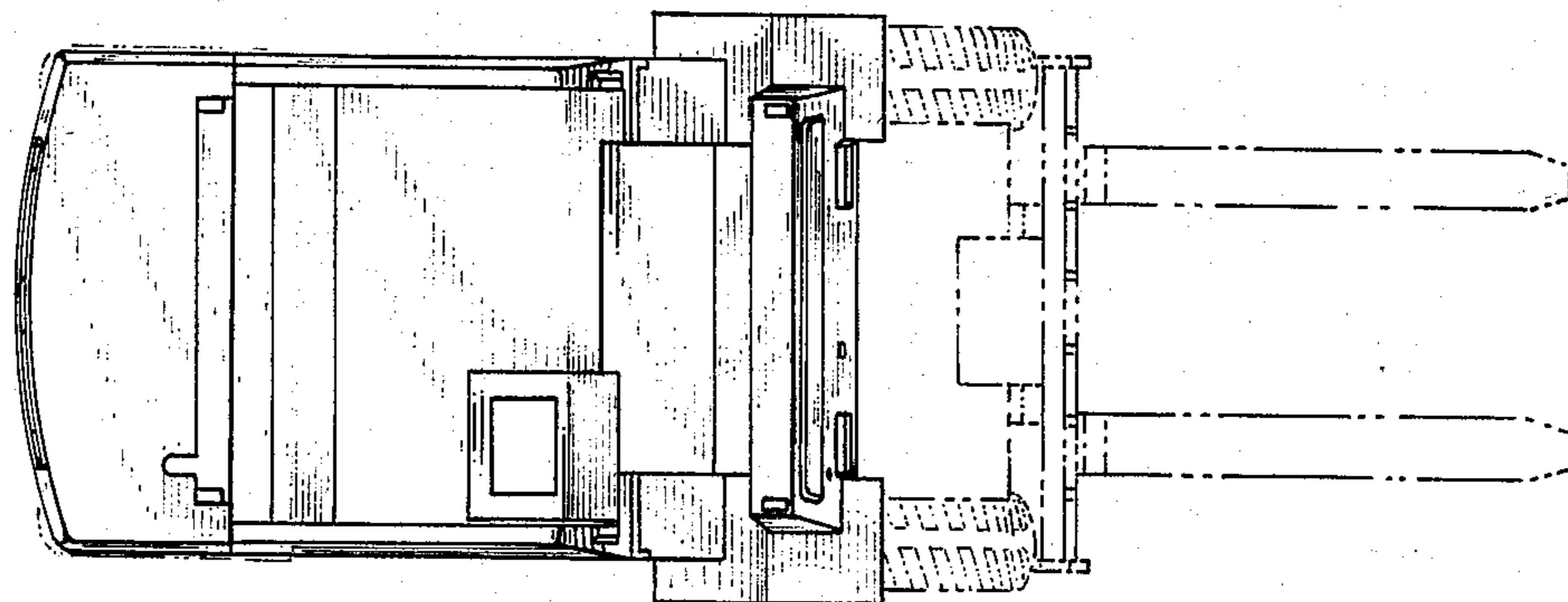
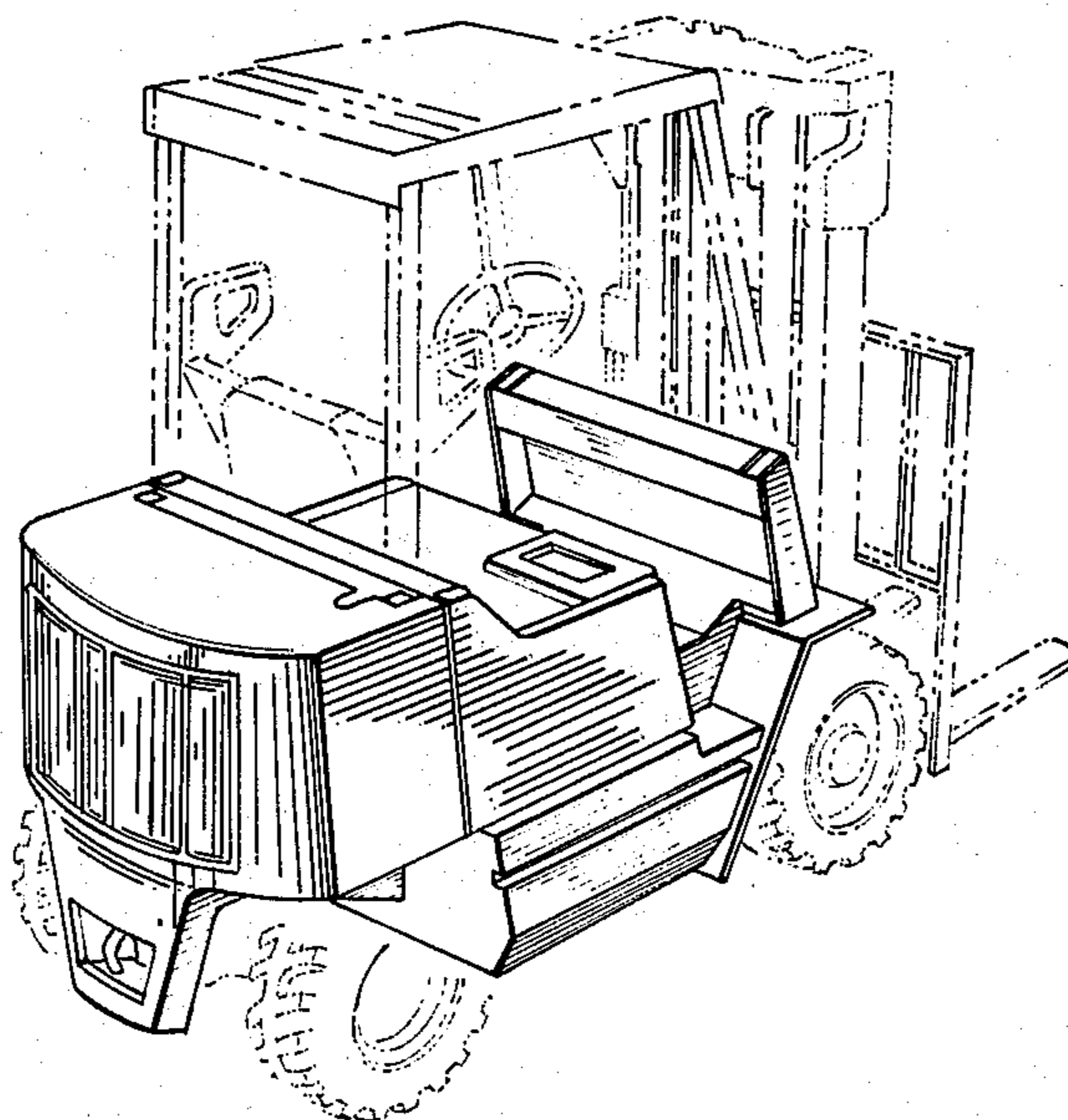

Fig. 7



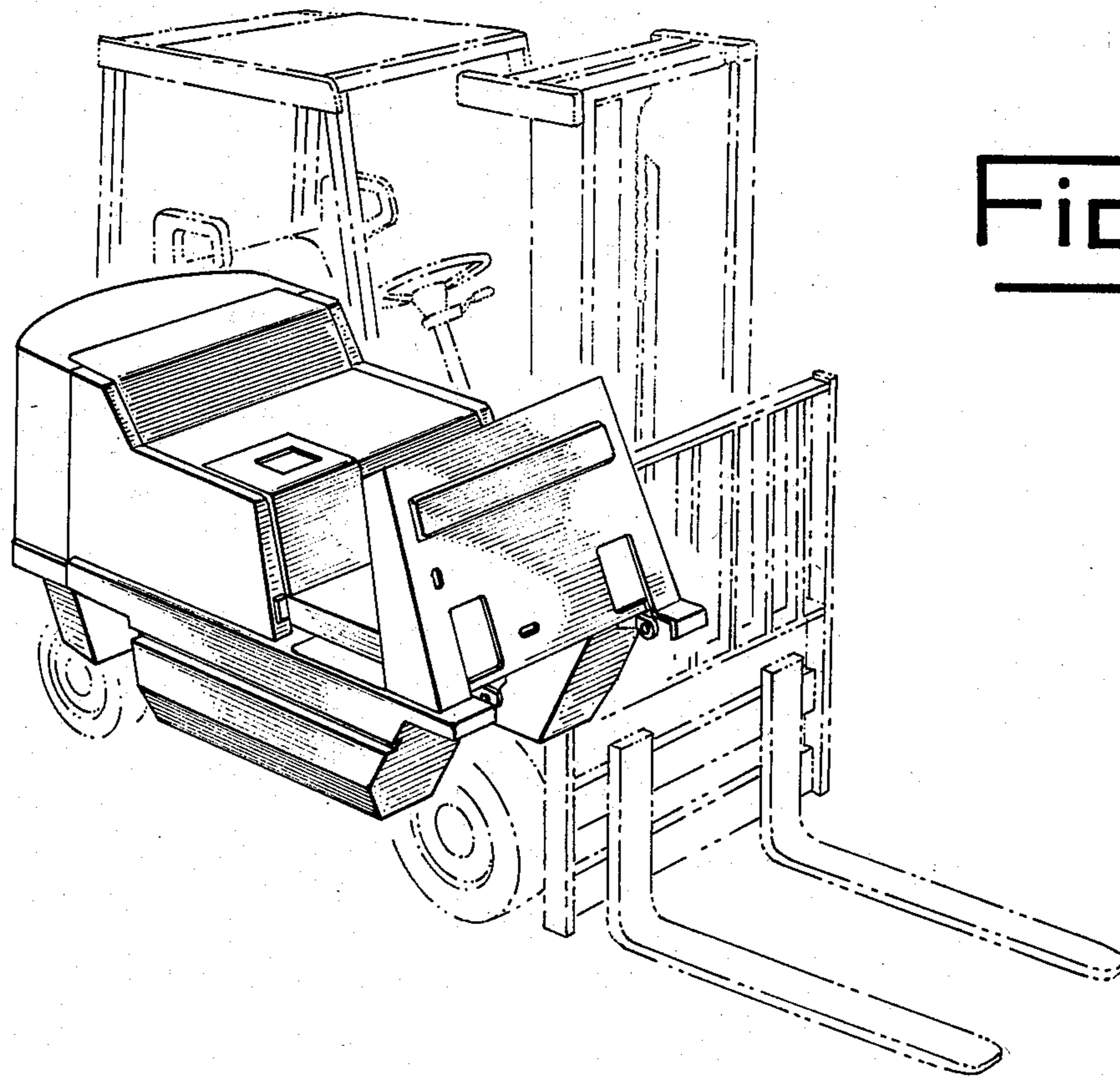

Fig. 8

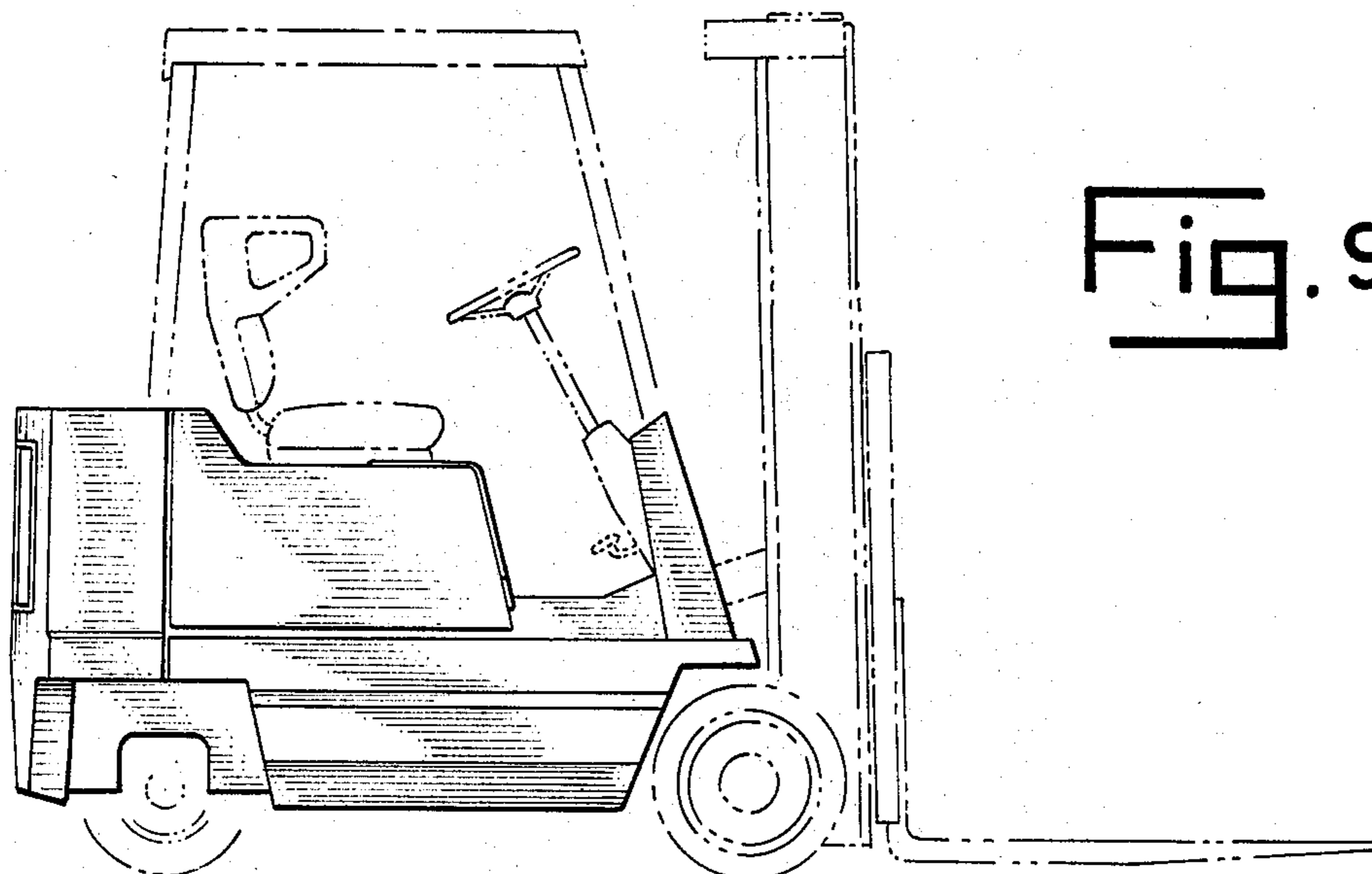

Fig. 9

Fig. 10

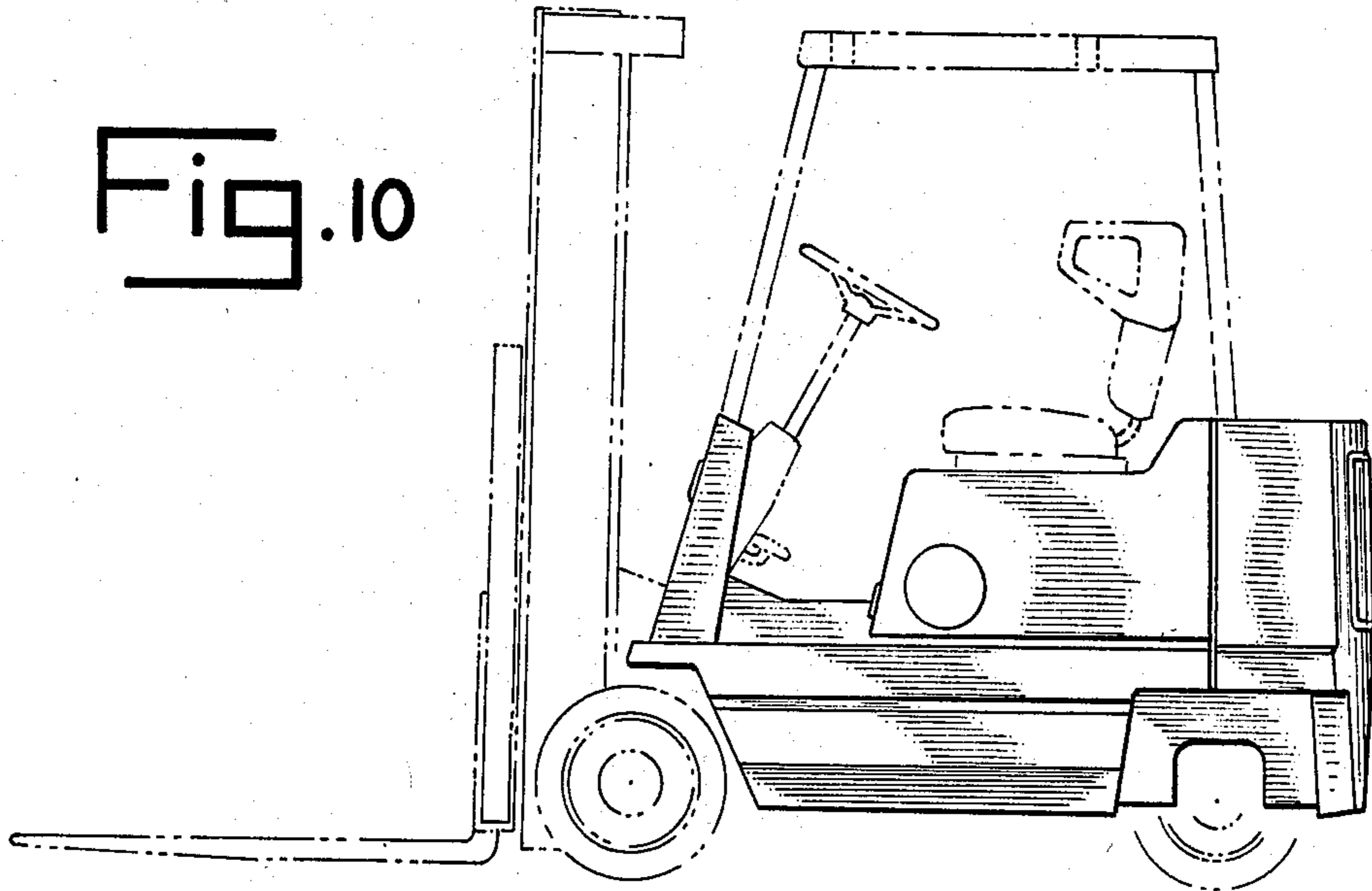

Fig. 11

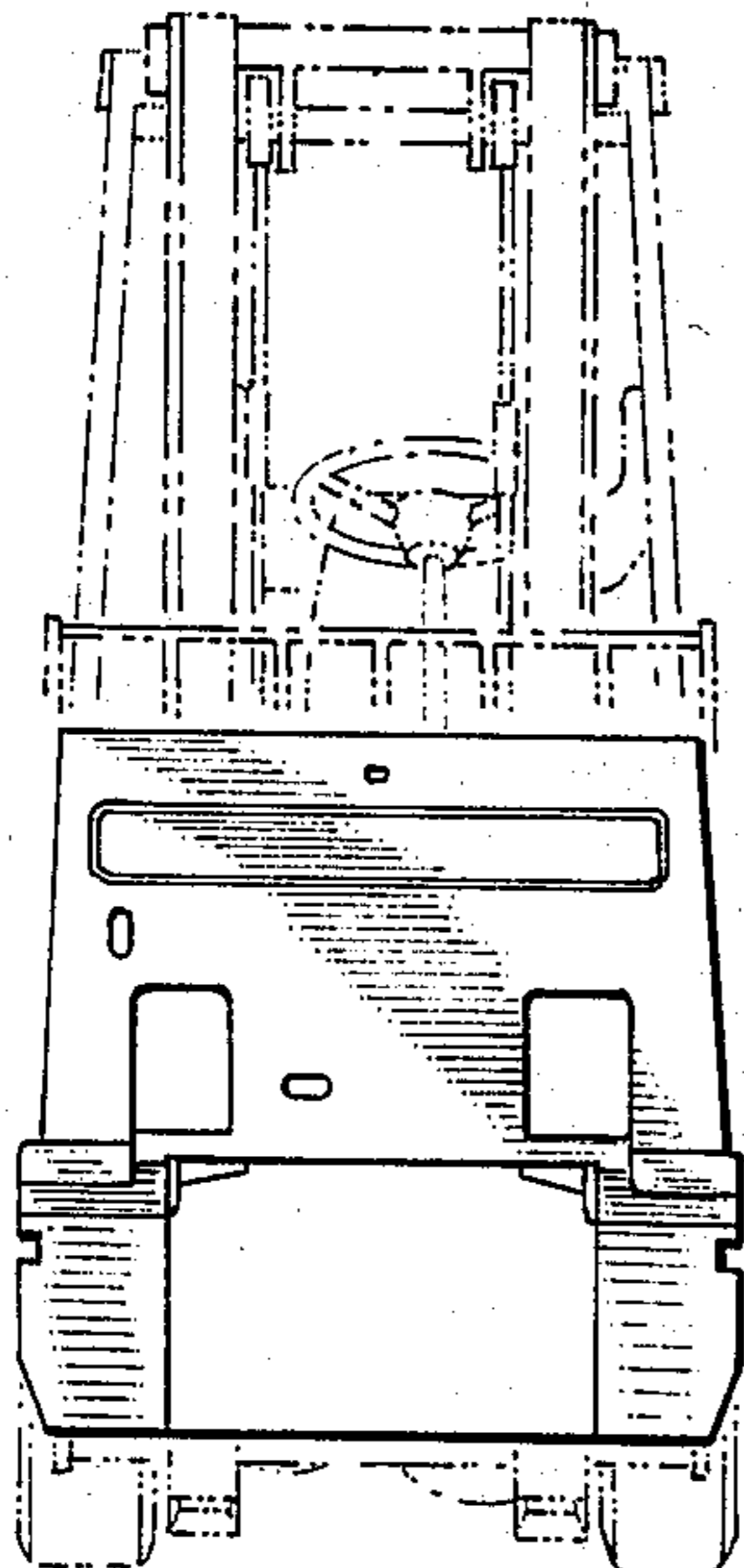

Fig. 12

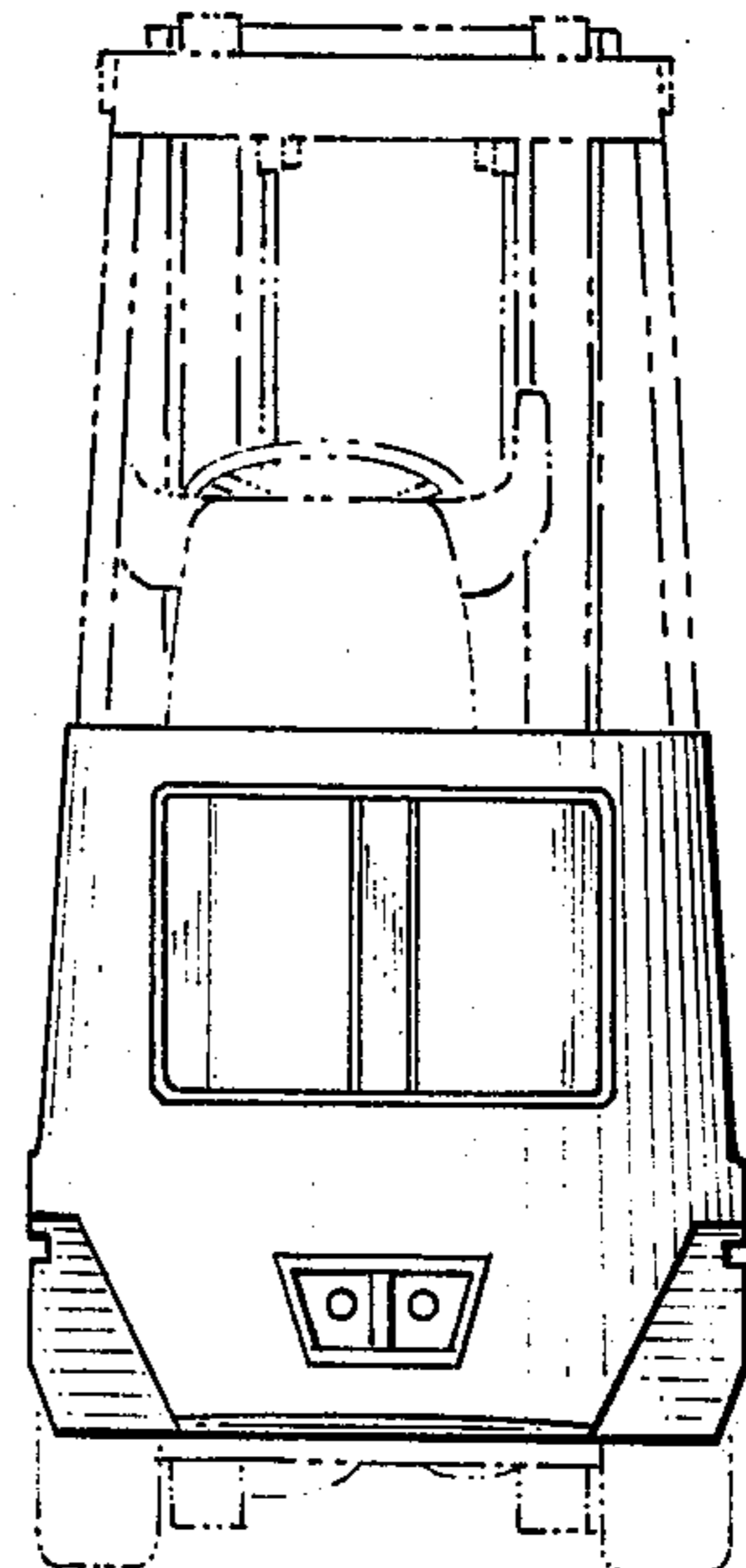

Fig. 13

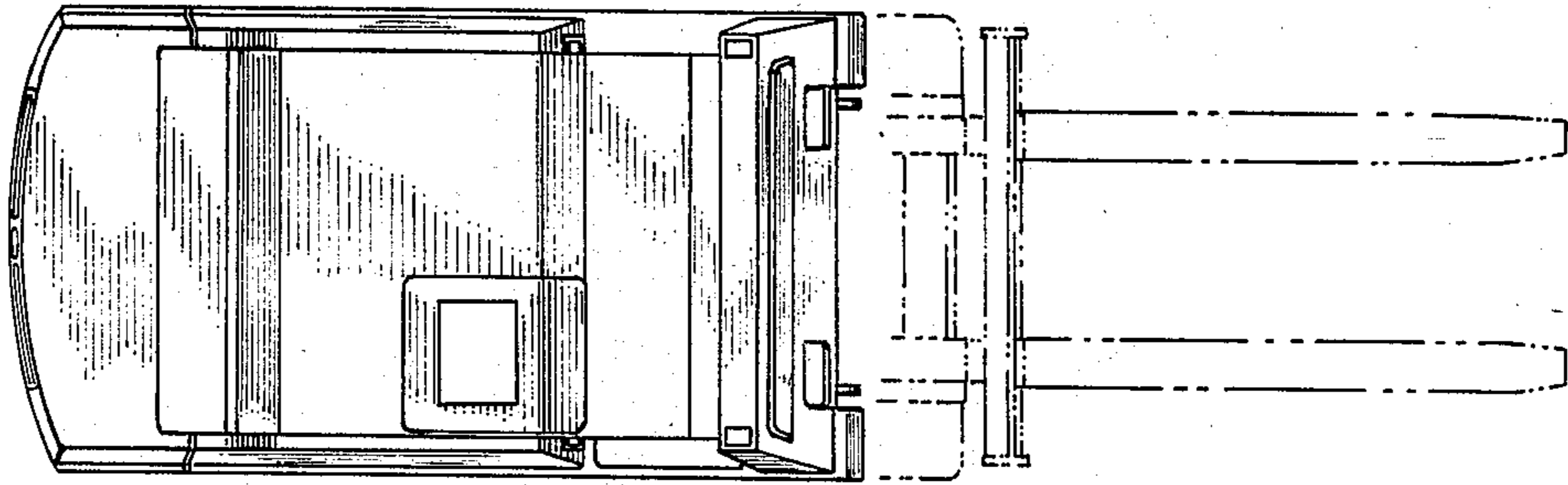

Fig. 14

