

- [54] **IDLER WHEEL FOR A TRACK VEHICLE**  
 [75] Inventors: Charles E. Grawey; Robert J. Grob; Cullen P. Hart, all of Peoria, Ill.  
 [73] Assignee: Caterpillar Inc., Peoria, Ill.  
 [\*\*] Term: 14 Years  
 [21] Appl. No.: 732,475  
 [22] Filed: May 9, 1985  
 [52] U.S. Cl. .... D15/28; D12/210; D12/212  
 [58] Field of Search ..... D15/10, 22-25, D15/28; 152/453, 523, 28.1, 209 B, 209 R, 209 NT, 209 WT, 209 D; 301/37 R, 37 P, 37 TC, 64 SD, 65; D12/210, 212, 204, 209

[56] **References Cited**

**U.S. PATENT DOCUMENTS**

D. 107,515	12/1937	Grange et al. ....	D12/135
D. 218,739	9/1970	Swisher, Jr. et al. ....	D15/25
D. 224,705	9/1972	Mattson .....	D12/204
1,297,104	3/1919	Colahan .	
1,411,523	4/1922	Schlueter .	
1,412,366	4/1922	Muret .	
1,684,070	9/1928	Pennington .	
2,338,817	1/1944	Mayne .....	305/10
2,350,076	5/1944	Smith et al. ....	305/10
2,429,242	10/1947	Slemmons .....	305/10
2,452,671	11/1948	Merrill .....	305/9
2,461,849	2/1949	Slemmons et al. ....	305/10
2,476,460	7/1949	Smith .....	305/10
2,476,828	7/1949	Skromme .....	305/10
2,494,065	1/1950	Slemmons .....	305/10
2,531,111	11/1950	Daniels .....	305/10
2,537,745	1/1951	Daniels .....	305/8
2,644,539	7/1953	Gazda .....	180/5
2,830,637	4/1958	Deuring et al. ....	152/49
2,898,965	8/1959	Eddy .....	152/175
2,937,904	5/1960	Barnes .....	301/37 TC
2,998,998	9/1961	Hylar et al. ....	305/31
3,105,536	10/1963	Cappa .....	152/183
3,323,811	6/1967	Nelson .....	280/104.5
3,369,622	2/1968	Thomas, Sr. ....	180/5
3,451,728	6/1969	Bruneau .....	305/35 EB
3,510,174	5/1970	Lamb .....	305/27
3,606,921	9/1971	Grawey .....	152/354
3,689,122	9/1972	Mazzarins .....	305/27
3,703,321	11/1972	Schoonover .....	305/38
3,746,361	7/1973	McGee .....	280/104.5
3,773,394	11/1973	Grawey .....	305/38
3,858,948	1/1975	Johnson et al. ....	305/35

4,198,103	4/1980	Ward et al. ....	305/12
4,241,956	12/1980	Meisel, Jr. ....	305/35
4,281,882	8/1981	van der Lely .....	305/35

**FOREIGN PATENT DOCUMENTS**

678785	6/1939	Fed. Rep. of Germany .
56-4551	1/1981	Japan .
56-7591	2/1981	Japan .
56-7592	2/1981	Japan .
56-14148	4/1981	Japan .
56-31494	7/1981	Japan .
56-33817	8/1981	Japan .
56-33818	8/1981	Japan .
57-8523	2/1982	Japan .
58-51668	11/1983	Japan .
59-3014	1/1984	Japan .
7605810	11/1977	Netherlands .
278779	10/1927	United Kingdom .
2048799	12/1980	United Kingdom .
1604615	12/1981	United Kingdom .
2048800	1/1983	United Kingdom .

**OTHER PUBLICATIONS**

Agricultural Engineer; Hemingway, Price, Scott; Winter 1982, pp. 109-112, Otter Tractor Corporation advertisement.  
 Japanese advertising circular, Forrex, Inc. advertisement; Makeri 33T; pp. 1-4.  
 Loegering Mfg. Inc. advertisement; pp. 1-2.  
 Rixmann Engineering Associates advertisement; pp. 1-19.  
 American Forests, Apr. 1985, p. 28, "Truck Tracks", French advertising circular.  
*Primary Examiner*—Wallace R. Burke  
*Assistant Examiner*—Ruth Takemoto  
*Attorney, Agent, or Firm*—Joseph W. Keen

[57] **CLAIM**

The ornamental design for an idler wheel for a track vehicle, as shown.

**DESCRIPTION**

FIG. 1 is a right side elevational view of an idler wheel for a track vehicle showing our new design; FIG. 2 is a left side elevational view thereof; FIG. 3 is a front elevational view thereof; FIG. 4 is a rear elevational view thereof; FIG. 5 is a top plan view thereof; FIG. 6 is a bottom plan view thereof; and, FIG. 7 is a sectional view thereof, taken along lines 7-7 in FIG. 1.

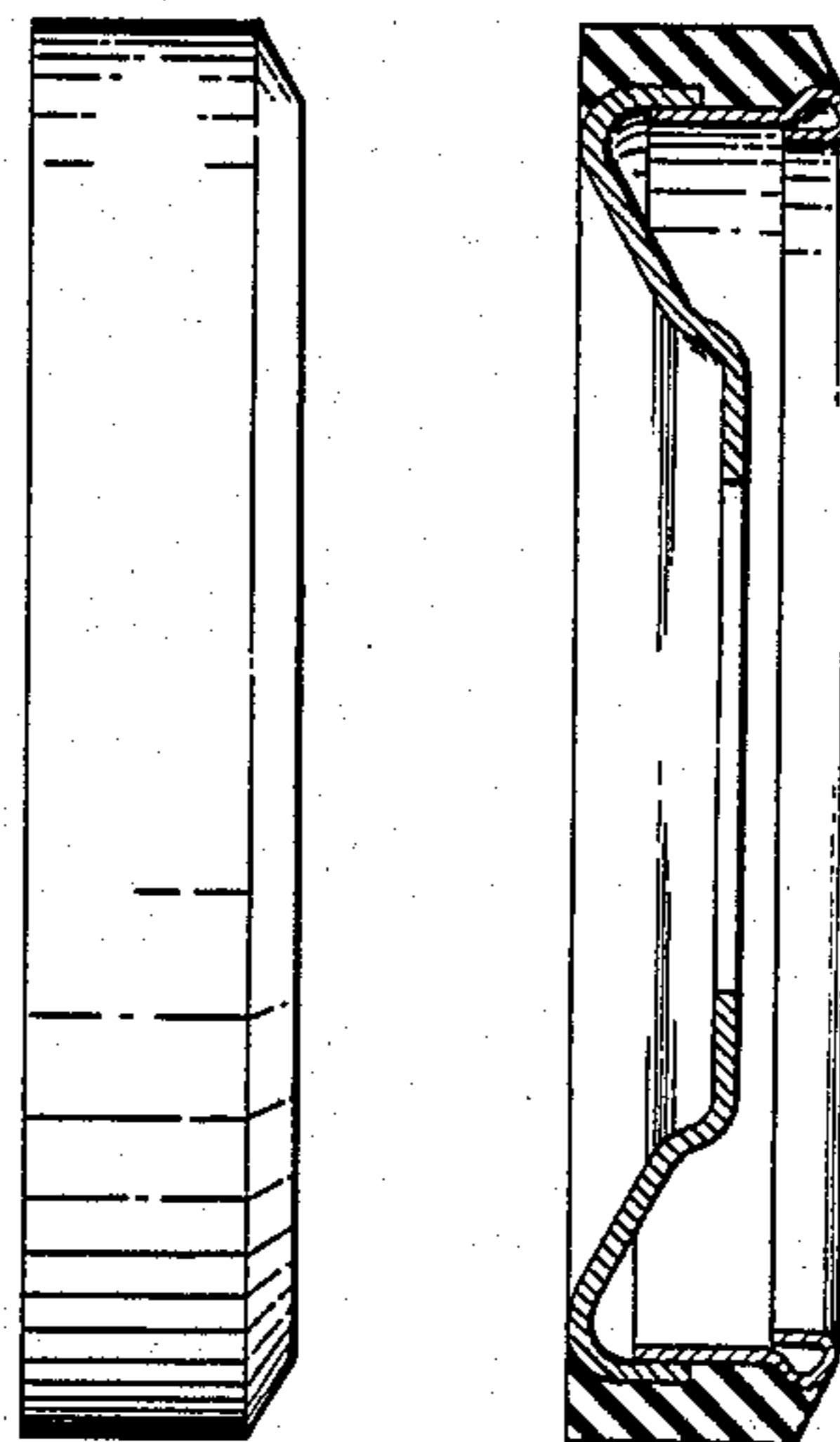
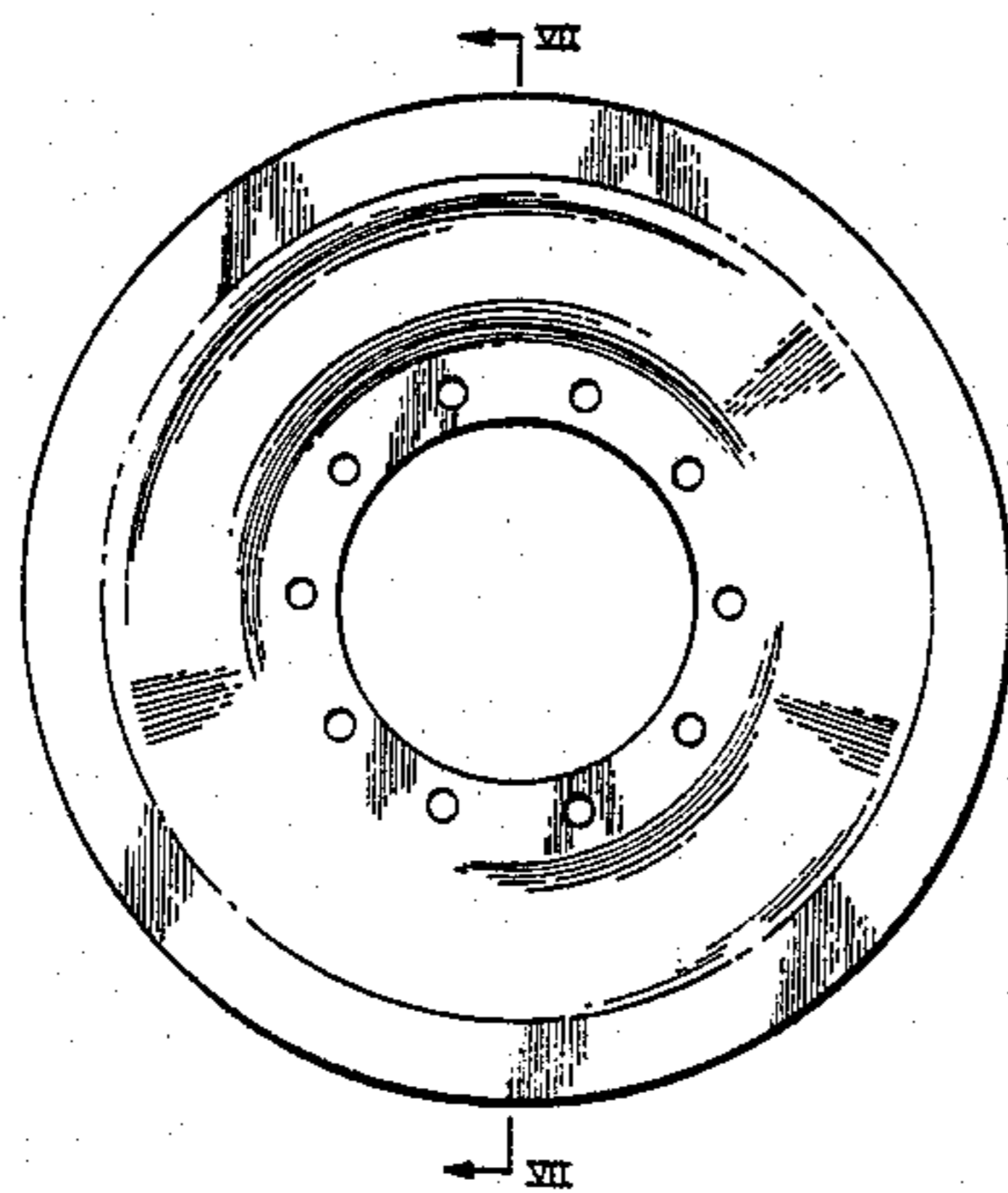

FIG 1

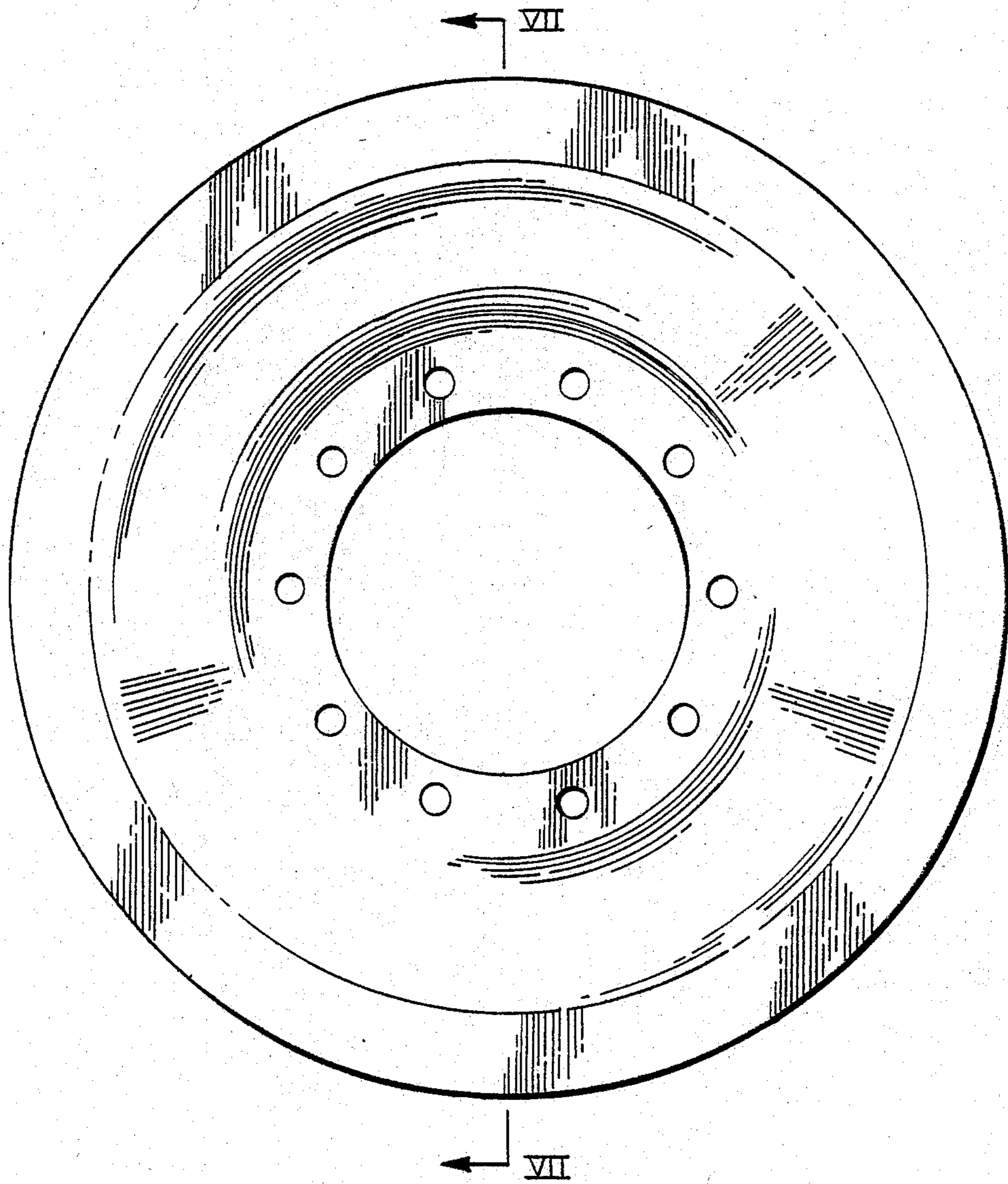



FIG. 2

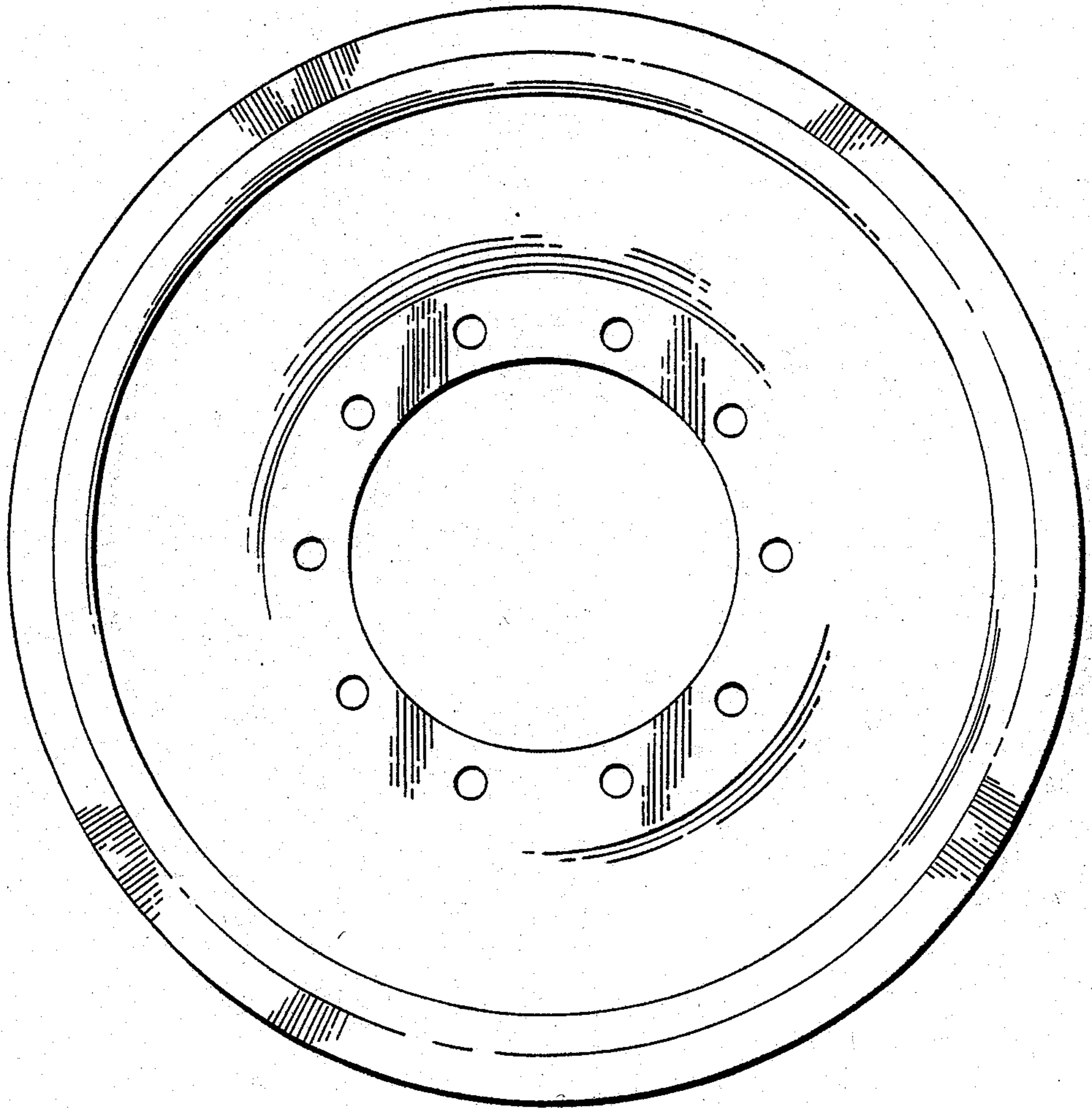

FIG. 3

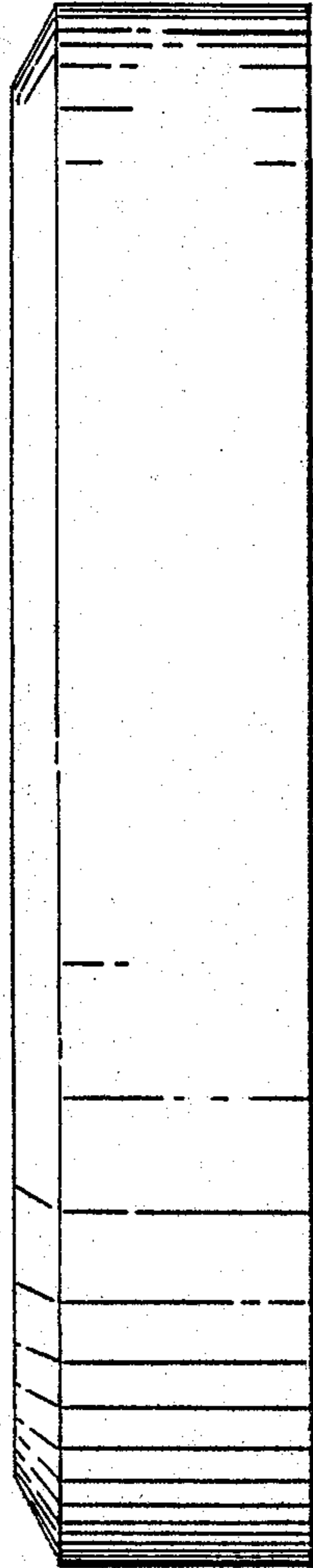

FIG. 4

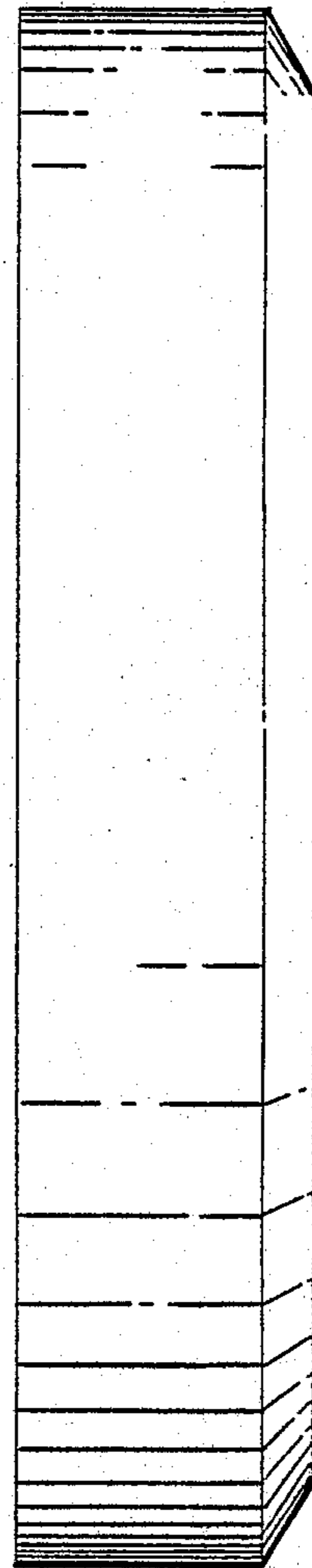

FIG-5

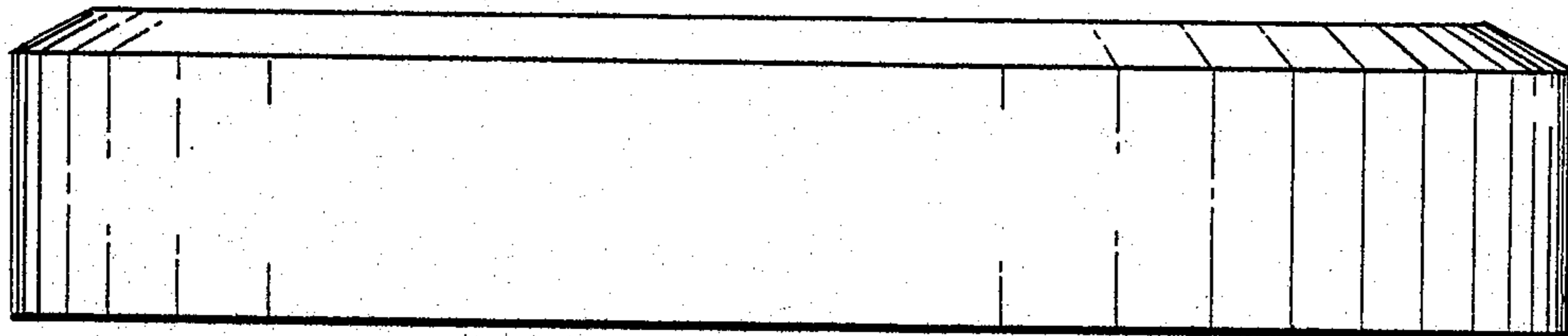

FIG-6

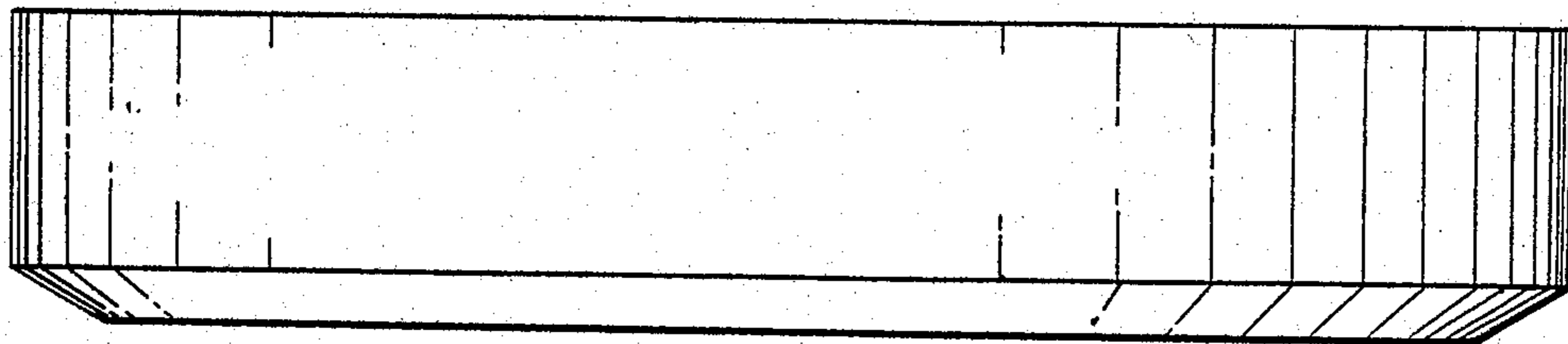

FIG. 7

