

[54] RETRACTABLE MARINE THRUST MOTOR

[75] Inventor: Derrick C. Richfield, Poole, England

[73] Assignee: Richfield Marine Thrusters Limited, Poole, England

[**] Term: 14 Years

[21] Appl. No.: 790,336

[22] Filed: Oct. 23, 1985

[30] Foreign Application Priority Data

Apr. 23, 1985 [GB] United Kingdom 1026368

[52] U.S. Cl. D15/4

[58] Field of Search D15/4; 440/6, 53-54, 440/71-72, 76-78, 111-112

[56] References Cited

U.S. PATENT DOCUMENTS

- D. 283,325 4/1986 Dickson D15/4
- 4,046,096 9/1977 Liaen 440/112
- 4,226,206 10/1980 Wilson 440/112
- 4,586,907 5/1986 Florander 440/112 X

FOREIGN PATENT DOCUMENTS

- 999062 7/1981 United Kingdom .
- 1004730 8/1982 United Kingdom .

Primary Examiner—Wallace R. Burke
Assistant Examiner—Brian N. Vinson
Attorney, Agent, or Firm—Arnold, White & Durkee

[57] CLAIM

The ornamental design for a retractable marine thrust motor, substantially as shown and described.

DESCRIPTION

FIG. 1 is a top, front and left side perspective view of a retractable marine thrust motor showing my new design in the retracted position;
FIG. 2 is a rear elevational view thereof;
FIG. 3 is a bottom plan view thereof;
FIG. 4 is a side elevational view thereof, shown in the extended position;
FIG. 5 is an opposite side elevational view thereof, shown in the extended position; and
FIG. 6 is a top, front and left side elevational view thereof, shown in the extended position with a portion broken-away for clarity of illustration.

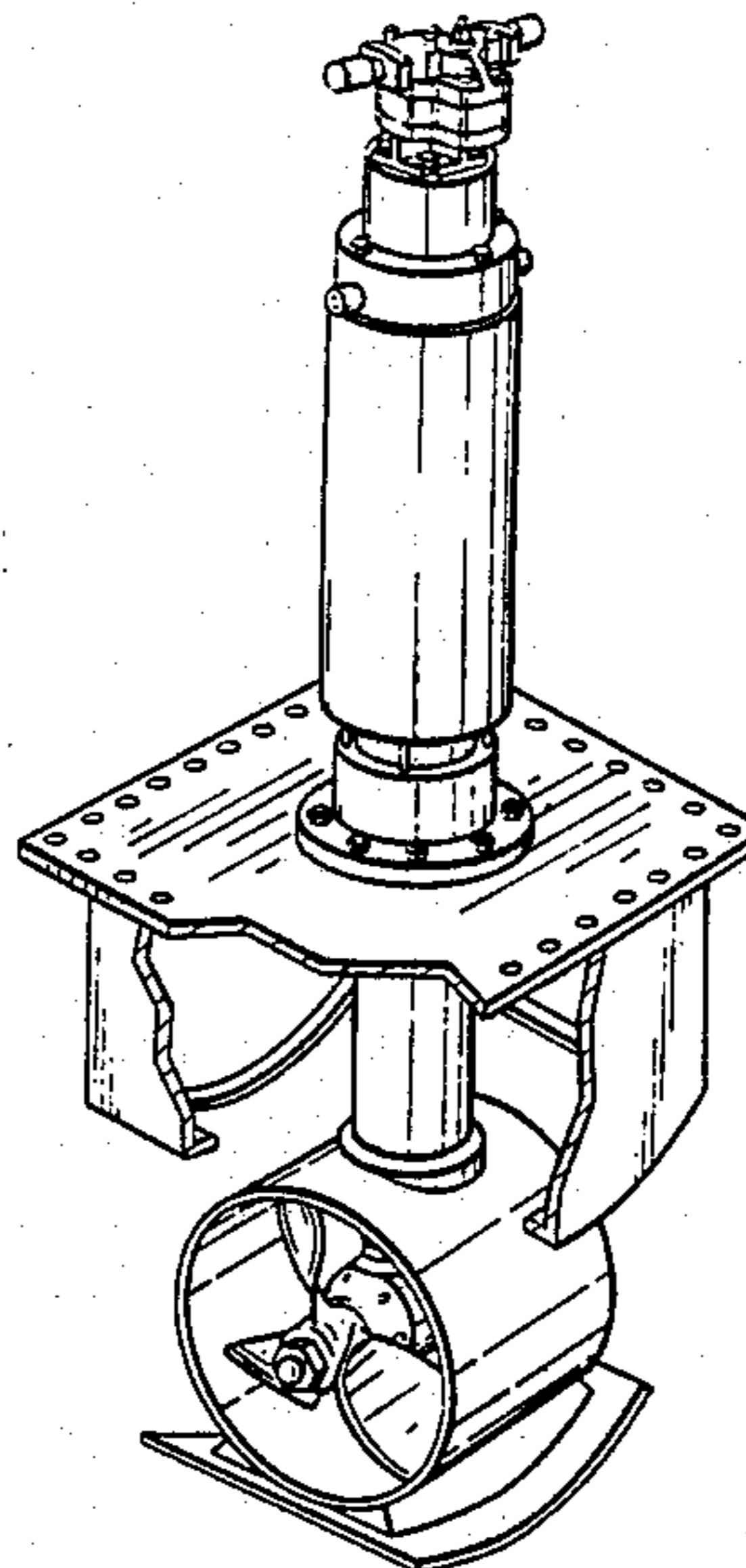
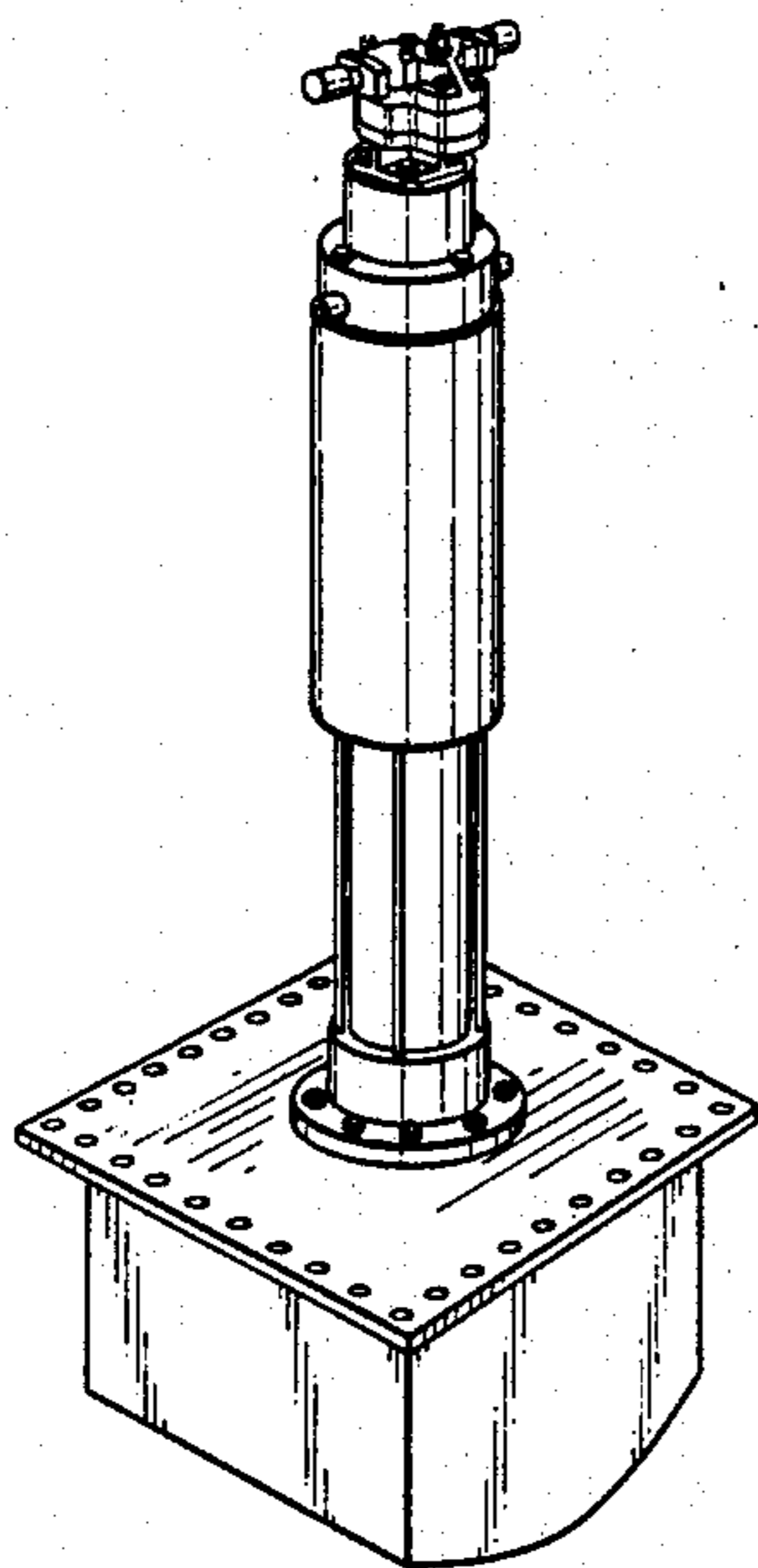

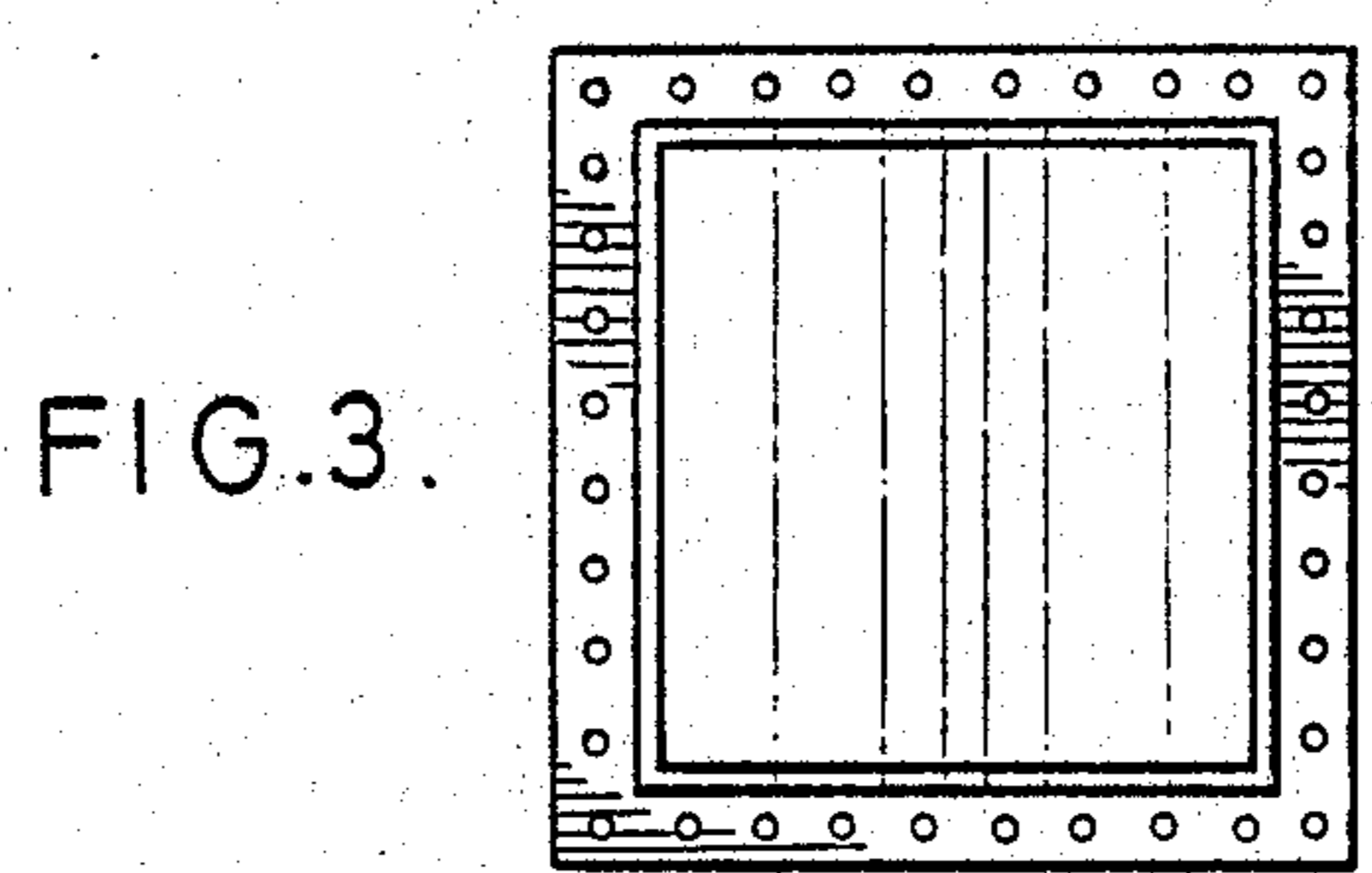
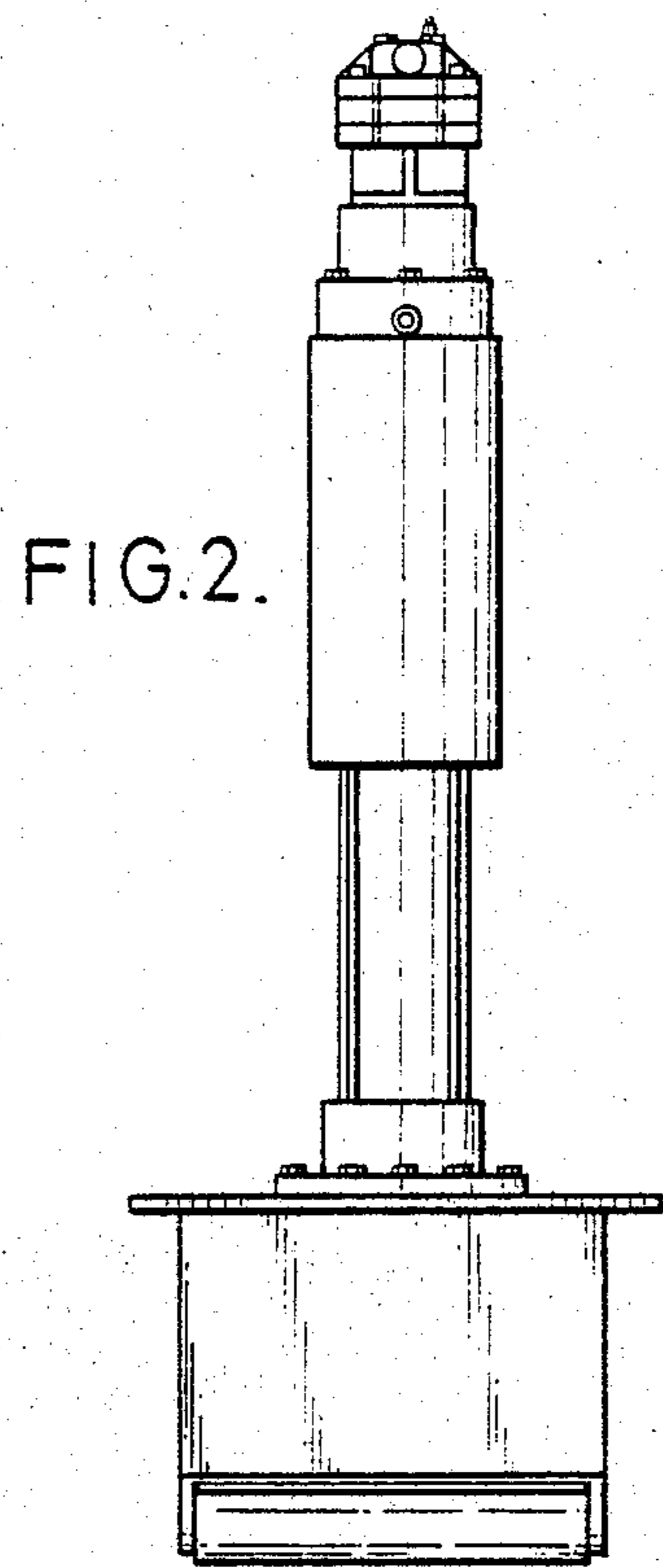
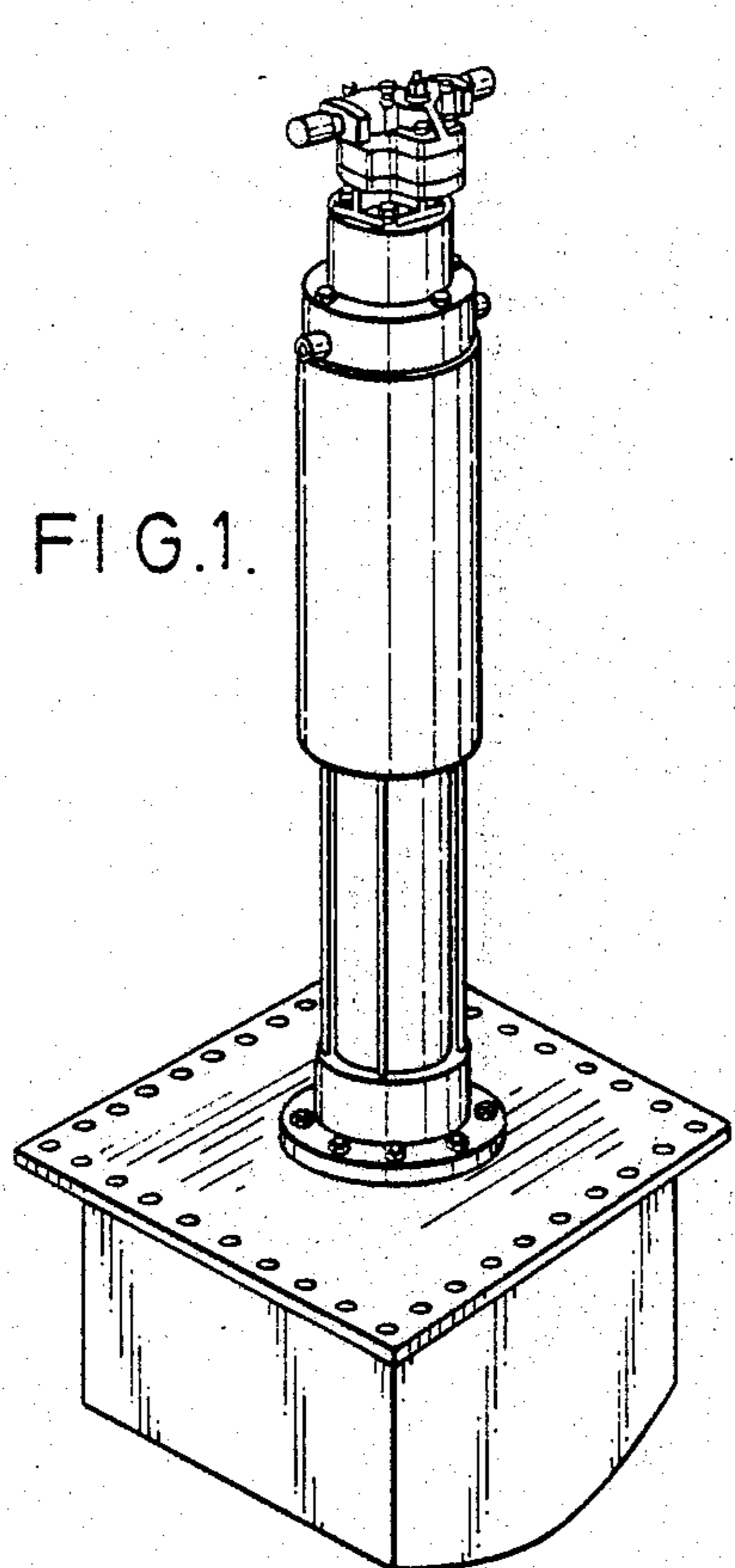

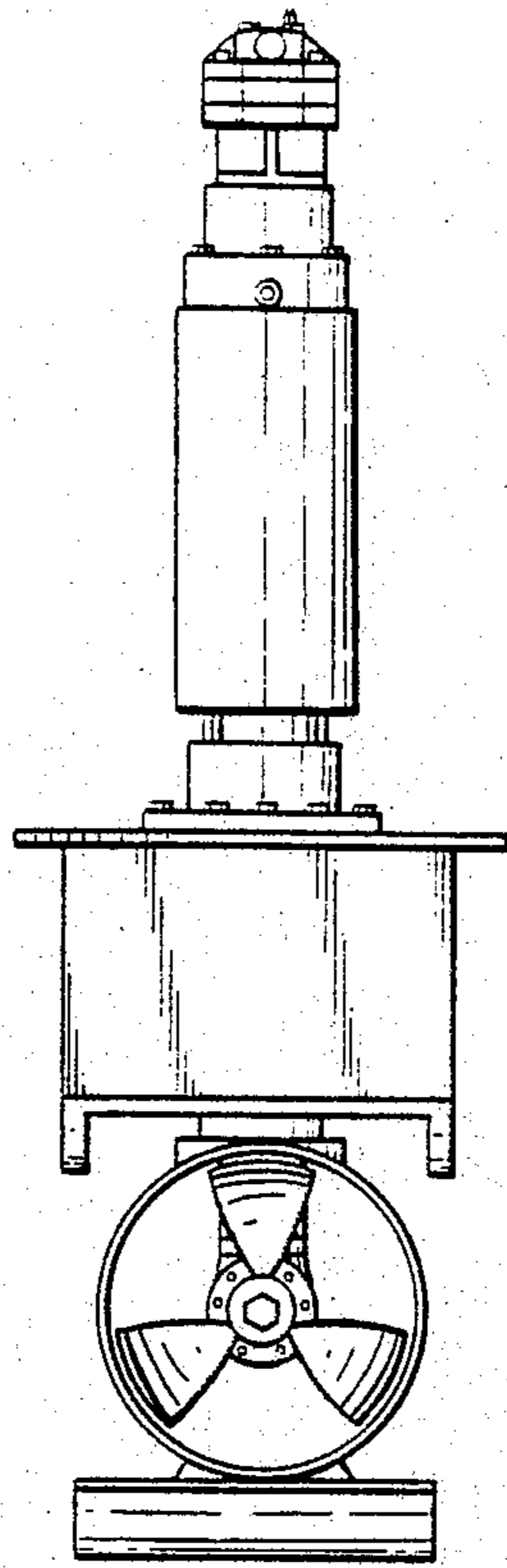

FIG. 4.

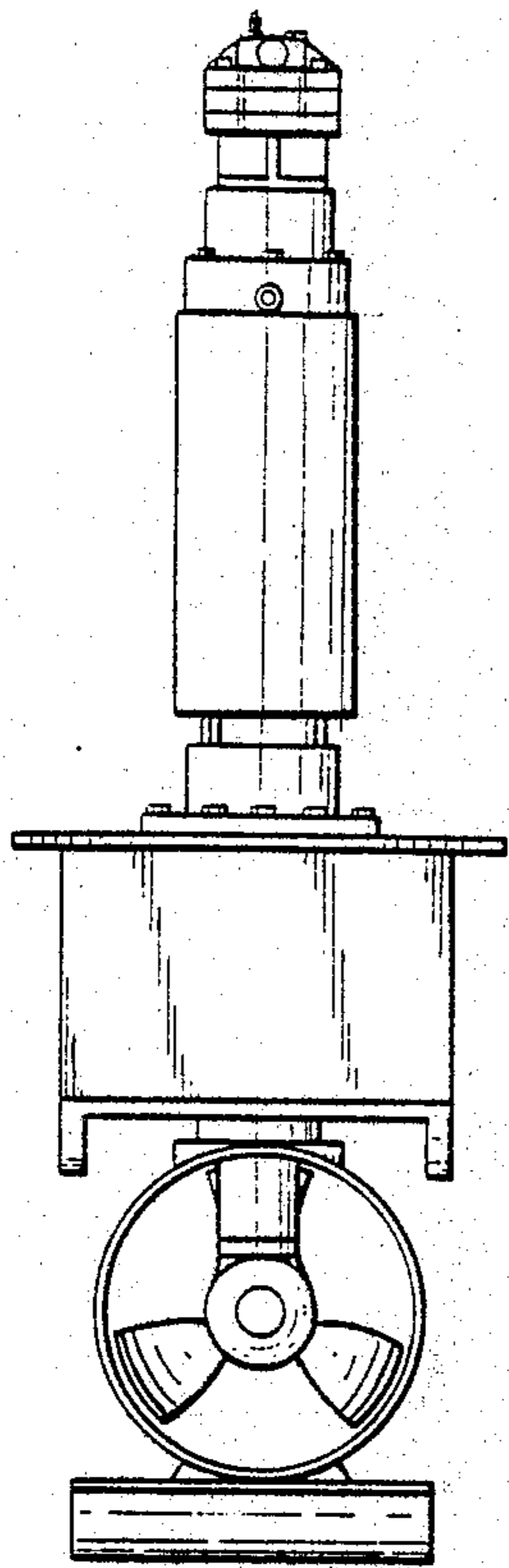

FIG. 5.

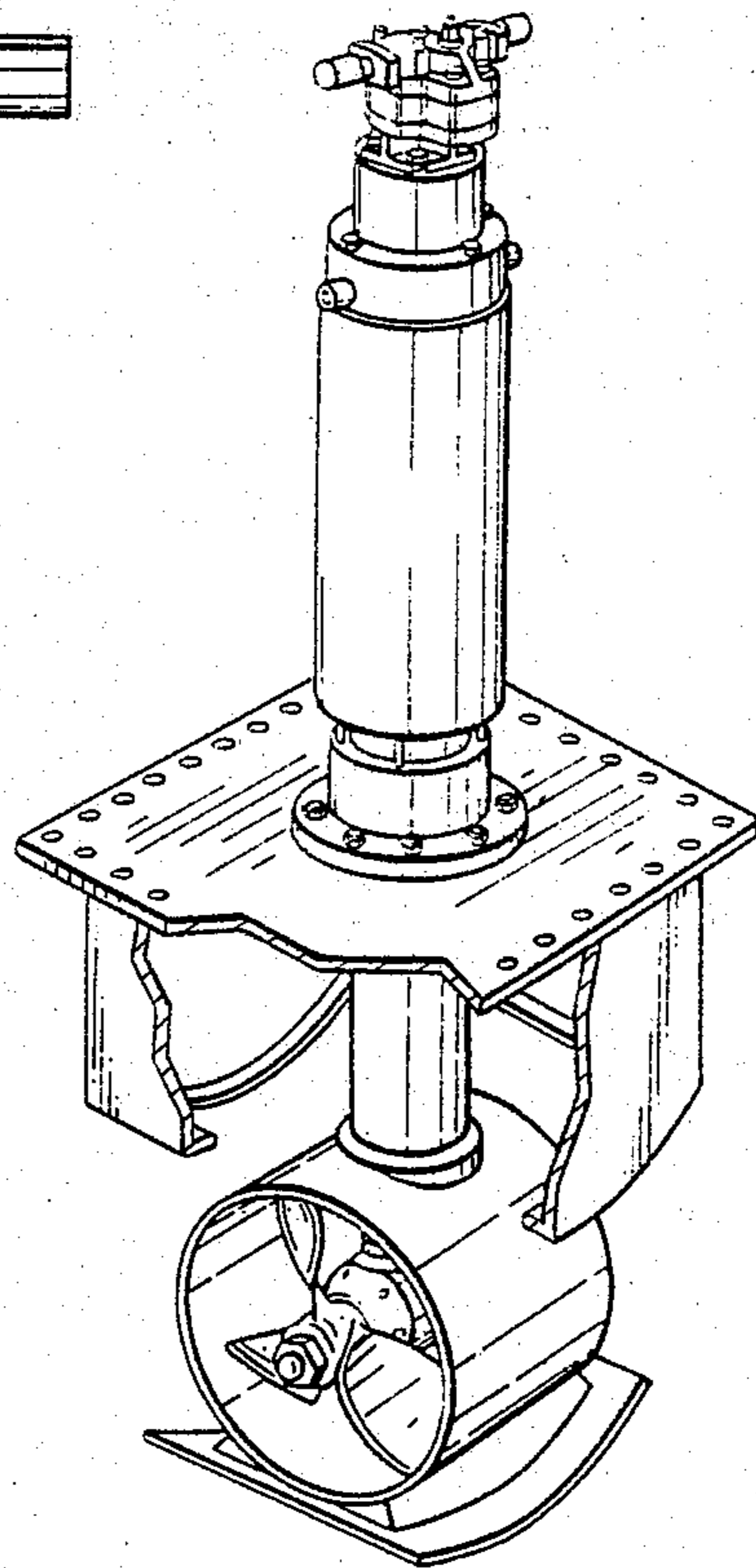

FIG. 6.