

United States Patent [19]

Masaki et al.

[11] Patent Number: **Des. 298,335**

[45] Date of Patent: **** Nov. 1, 1988**

[54] **DRUM KIT FOR
ELECTROPHOTOGRAPHIC COPIER**

[75] Inventors: **Nobuo Masaki, Kawasaki; Naoki
Tashiro, Tokyo, both of Japan**

[73] Assignee: **Canon Kabushiki Kaisha, Tokyo,
Japan**

[**] Term: **14 Years**

[21] Appl. No.: **819,309**

[22] Filed: **Jan. 16, 1986**

[30] **Foreign Application Priority Data**

Jul. 19, 1985 [JP] Japan 60-30947

[52] U.S. Cl. **D16/32**

[58] Field of Search **D16/27-32;
355/3 R, 3 DD, 3 DR, 11, 14 D, 14 R**

[56] **References Cited**

U.S. PATENT DOCUMENTS

D. 276,916 12/1984 Masaki D16/32
D. 286,297 10/1986 Clowe D16/32

D. 286,541 11/1986 Takahashi D16/32
D. 287,023 12/1986 Masaki D16/32
3,999,514 12/1976 Abbott 355/3 DD X
4,432,632 2/1984 Yokota 355/3 DD
4,530,588 7/1985 Kimura 355/3 DD X
4,657,369 4/1987 Takeuchi 355/3 DD X

Primary Examiner—Nelson C. Holtje
Attorney, Agent, or Firm—Fitzpatrick, Cella, Harper &
Scinto

[57] CLAIM

The ornamental design for a drum kit for electrophotographic copier, as shown and described.

DESCRIPTION

FIG. 1 is a front elevational view of a drum kit for electrophotographic copier showing our new design; FIG. 2 is a rear elevational view thereof; FIG. 3 is a top plan view thereof; FIG. 4 is a bottom plan view thereof; FIG. 5 is a left side elevational view thereof; FIG. 6 is a right side elevational view thereof; FIG. 7 is a top and right front perspective view thereof.

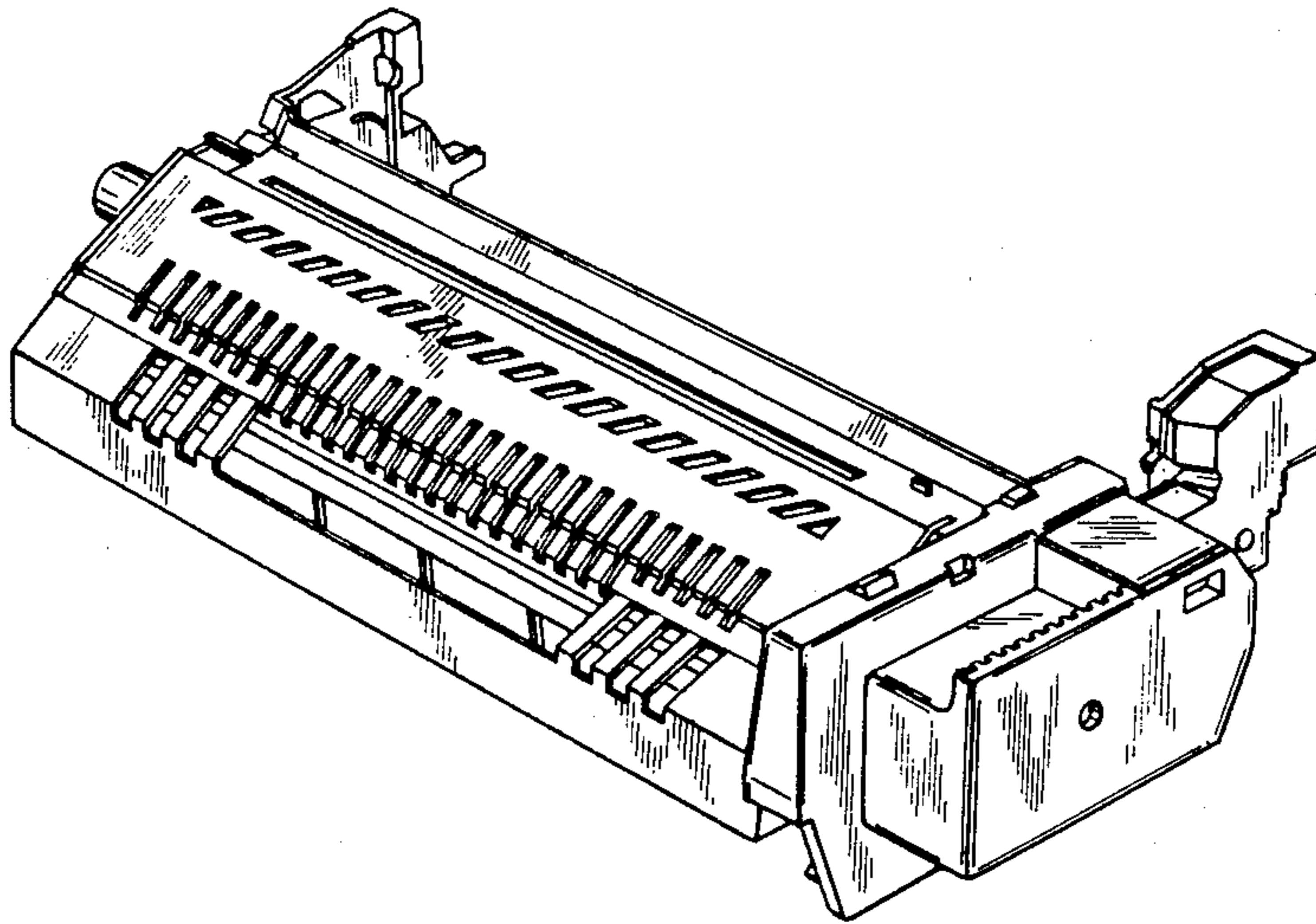

FIG. 1

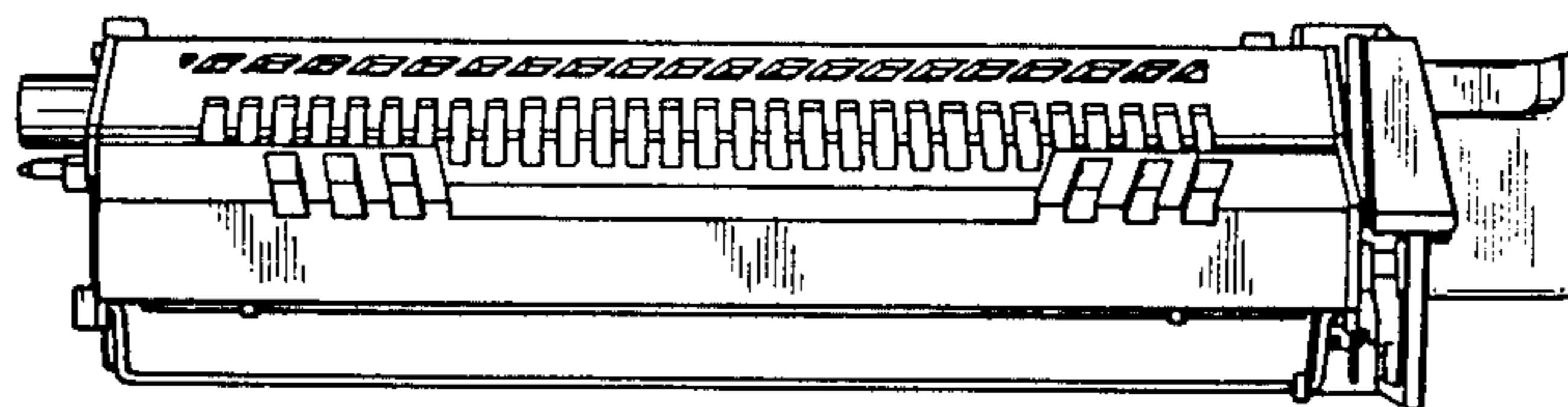

FIG. 2

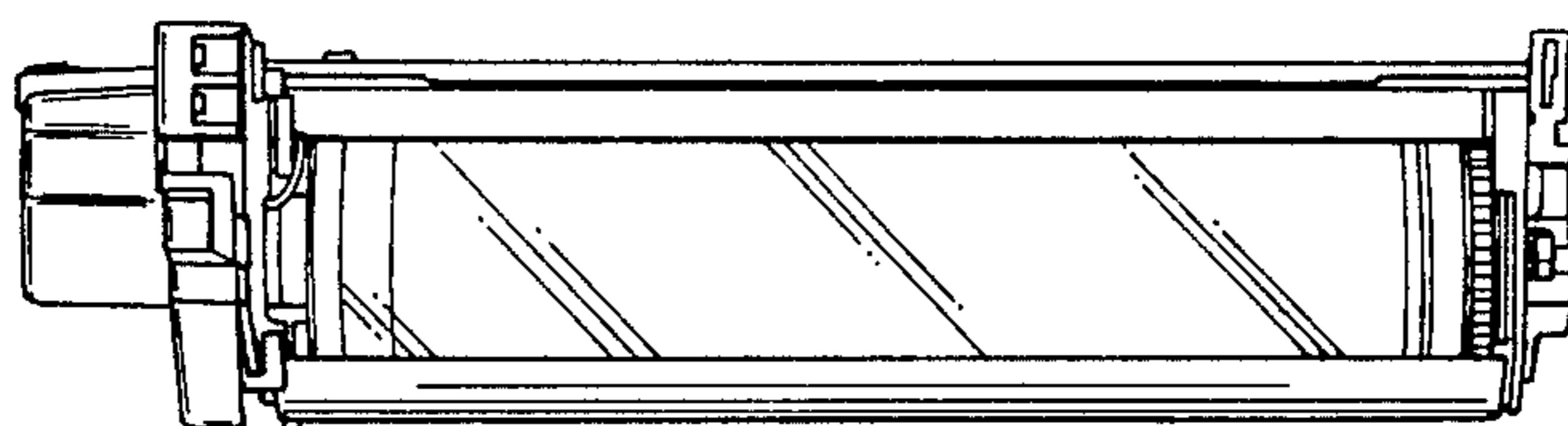

FIG. 3

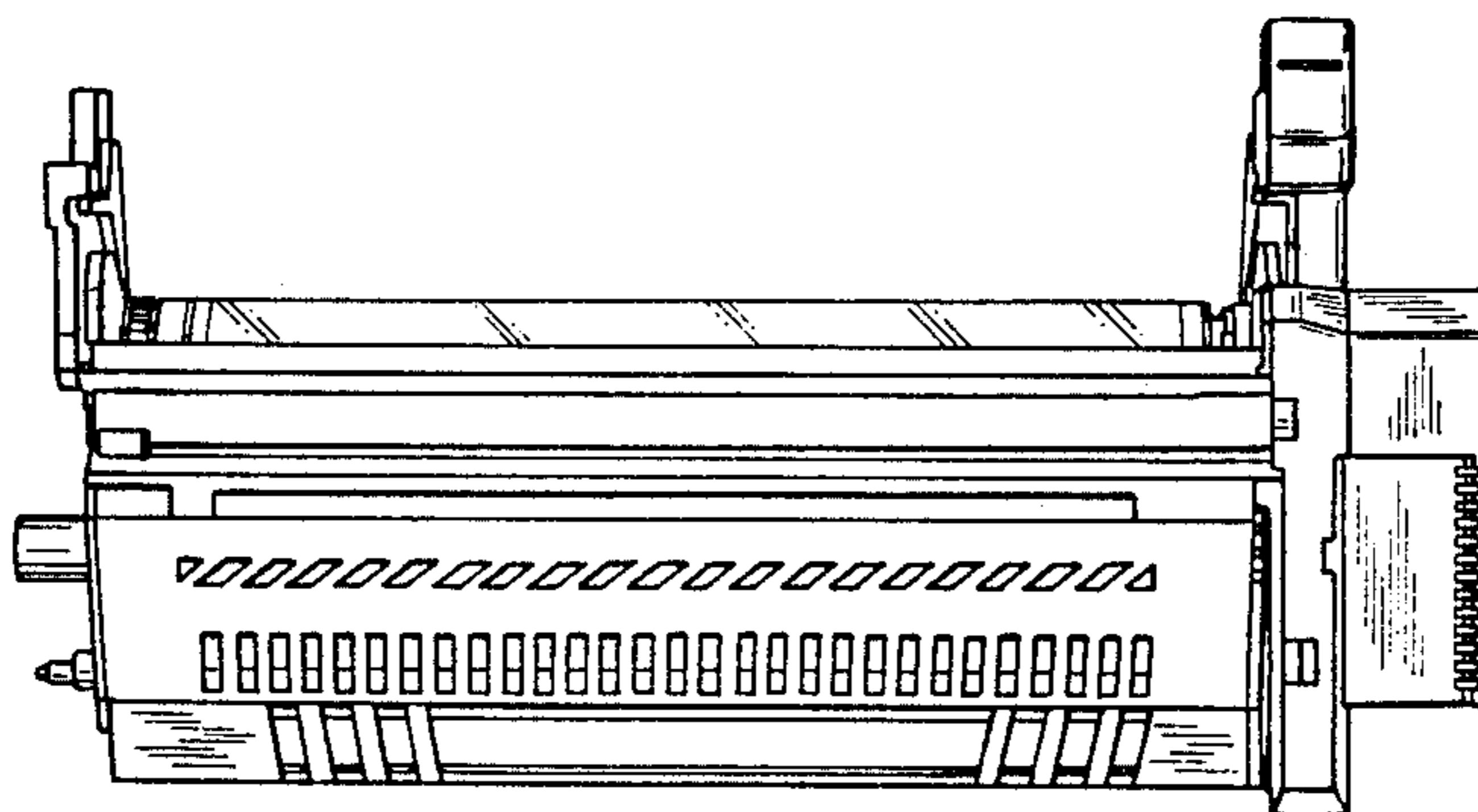

FIG. 4

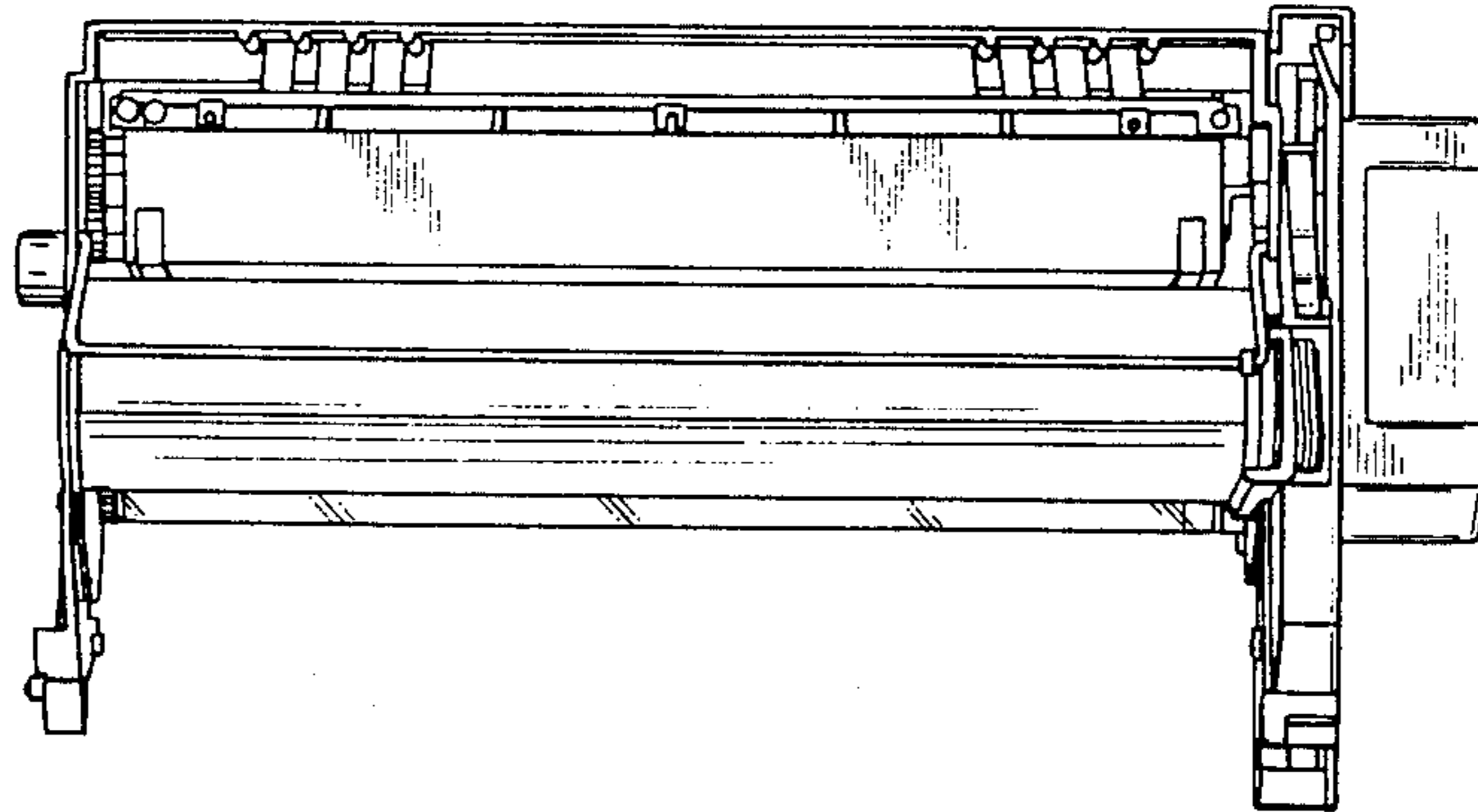

FIG. 5

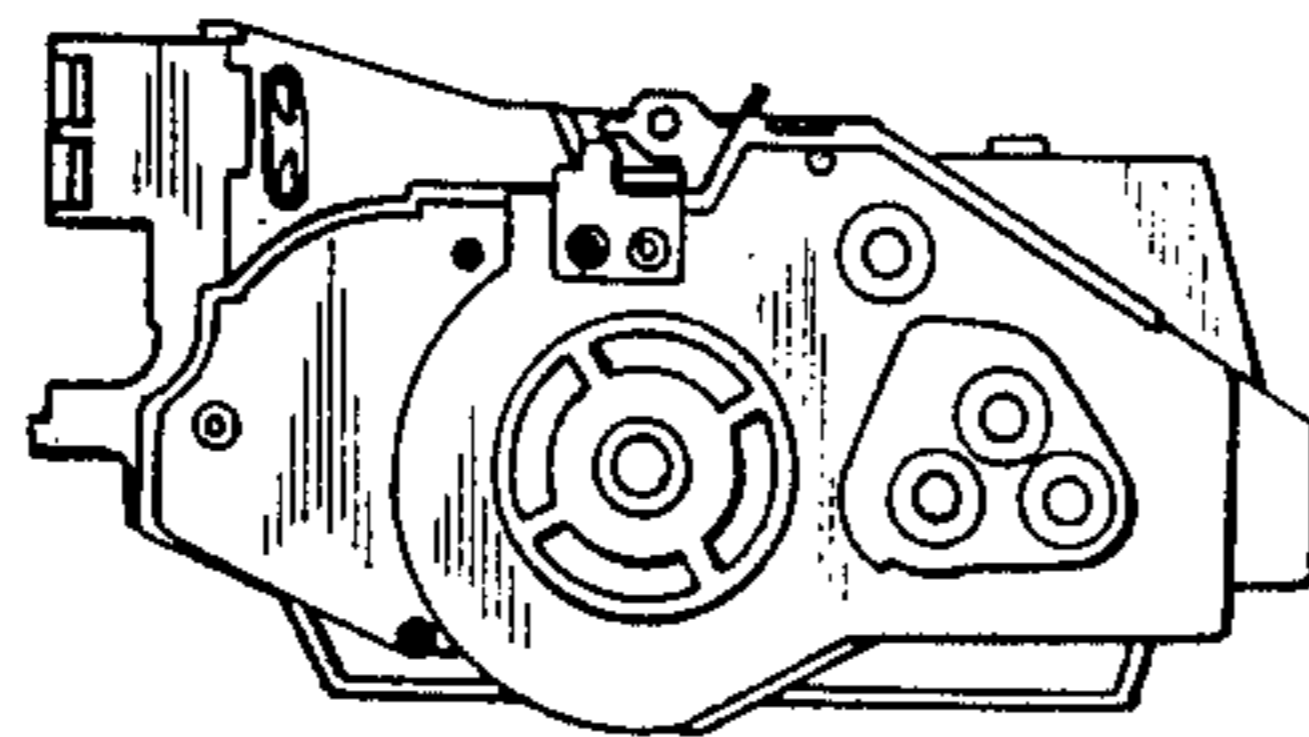

FIG. 6

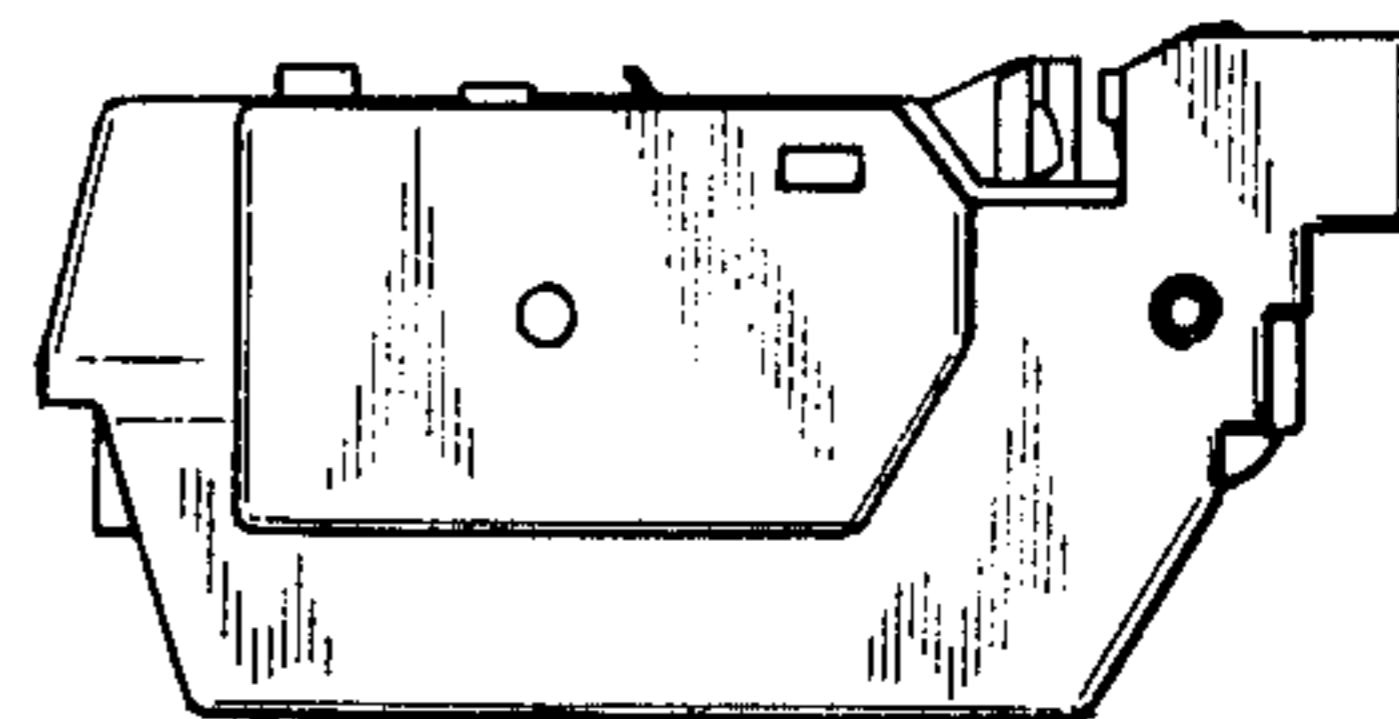

FIG. 7

