

[54] **SHIELDING FOR AGRICULTURAL BALERS**

[75] **Inventors: Robert R. Todd, Leola; Constantine J. Kermes, Lancaster, both of Pa.**

[73] **Assignee: New Holland Inc., New Holland, Pa.**

[**] **Term: 14 Years**

[21] **Appl. No.: 836,184**

[22] **Filed: Feb. 26, 1986**

[52] **U.S. Cl. D15/33**

[58] **Field of Search D15/10-13, D15/27-28, 33; 298/7, 24, 25, 26, 27**

[56] **References Cited**

U.S. PATENT DOCUMENTS

D. 174,898	6/1955	Eby et al.	D15/27
D. 182,287	3/1958	Kermes et al.	D15/27
D. 184,568	3/1959	Kermes	D15/27
D. 187,607	4/1960	Kermes et al.	D15/26
D. 188,800	9/1960	Kermes et al.	D15/27
D. 196,851	11/1963	Kermes	D15/27
D. 198,042	4/1964	McGirk et al.	D15/27
D. 199,798	12/1964	Bywater et al.	D15/27
D. 200,423	2/1965	Kermes	D15/27
D. 207,855	6/1967	Kermes	D15/27
D. 249,520	9/1978	Van Mill	D15/27
D. 284,116	6/1986	Linde	D15/13
D. 284,382	6/1986	Black et al.	D15/13
D. 294,583	3/1988	Blumer et al.	D15/27

2,774,456	12/1956	Presler	298/7
3,318,486	5/1967	Felix	298/24
3,700,283	10/1972	Birdsau	298/7
4,324,434	4/1982	Friese	D15/27

Primary Examiner—Wallace R. Burke
Assistant Examiner—Ruth Takemoto
Attorney, Agent, or Firm—Darrell F. Marquette; Frank A. Seemar; Larry W. Miller

[57] **CLAIM**

The ornamental design for shielding for agricultural balers, as shown and described.

DESCRIPTION

FIG. 1 is a perspective view of a shielding for agricultural balers showing our new design; FIG. 2 is a front elevational view thereof; FIG. 3 is a rear elevational view thereof; FIG. 4 is a right side elevational view thereof; FIG. 5 is a left side elevational view thereof; FIG. 6 is a perspective view of a second embodiment thereof; FIG. 7 is a right side elevational view thereof; FIG. 8 is a left side elevational view thereof; and FIG. 9 is a front elevational view thereof, the rear view being identical to FIG. 3. The undisclosed top is open and unornamented, and the undisclosed bottom is unornamented. The broken lines in FIGS. 1 and 6 are for illustrative purposes only and form no part of the claimed design.

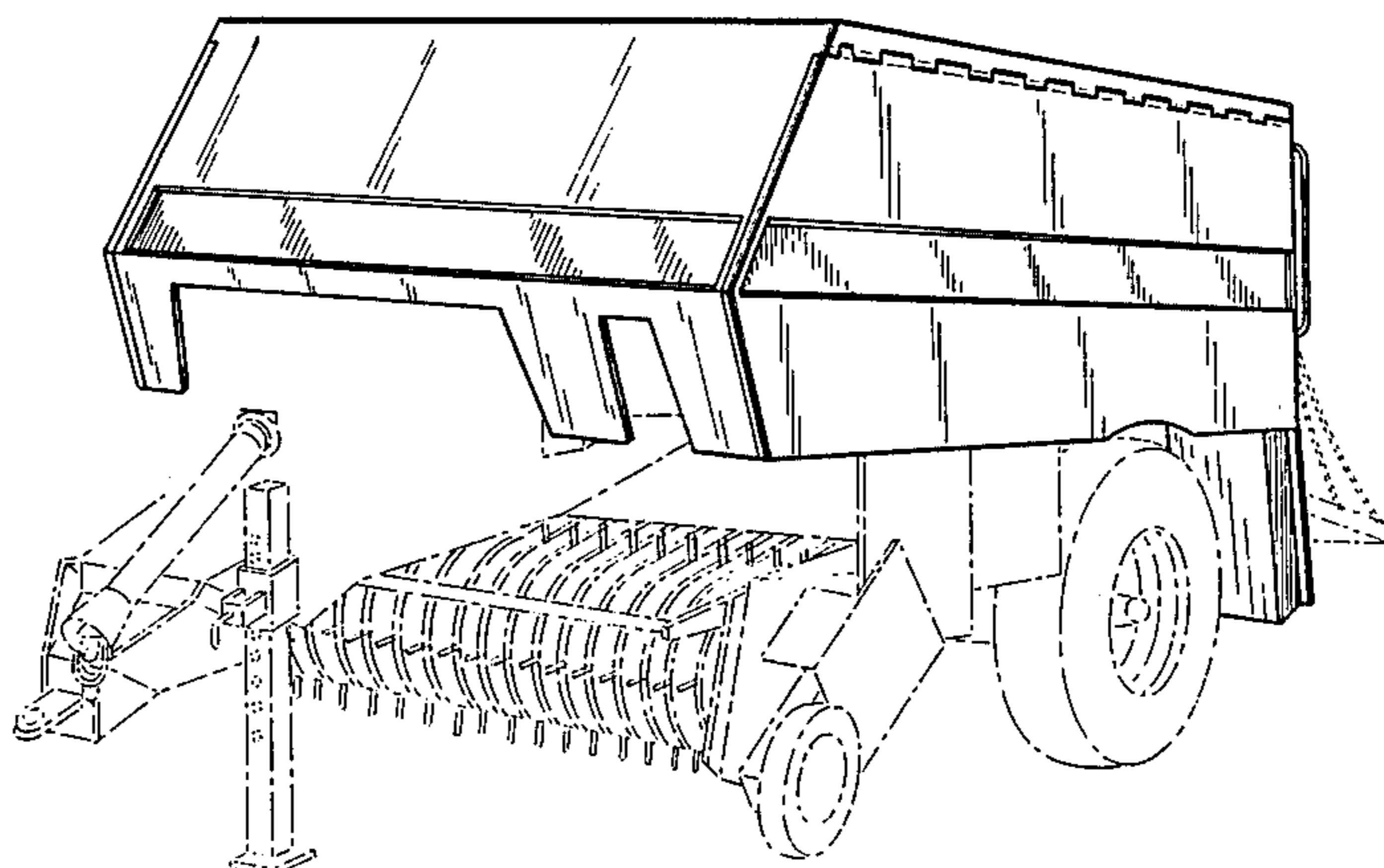
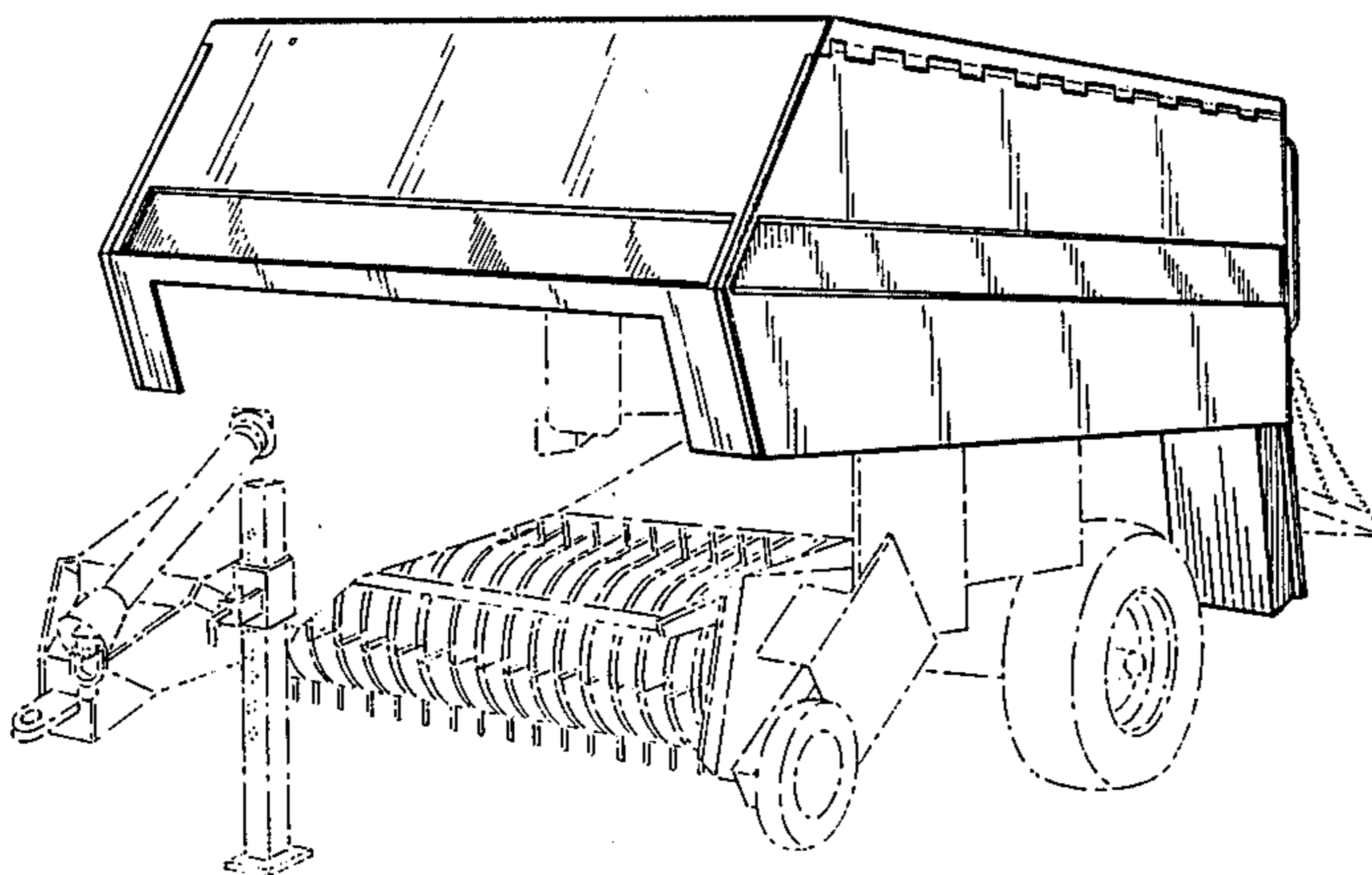

Fig. 1

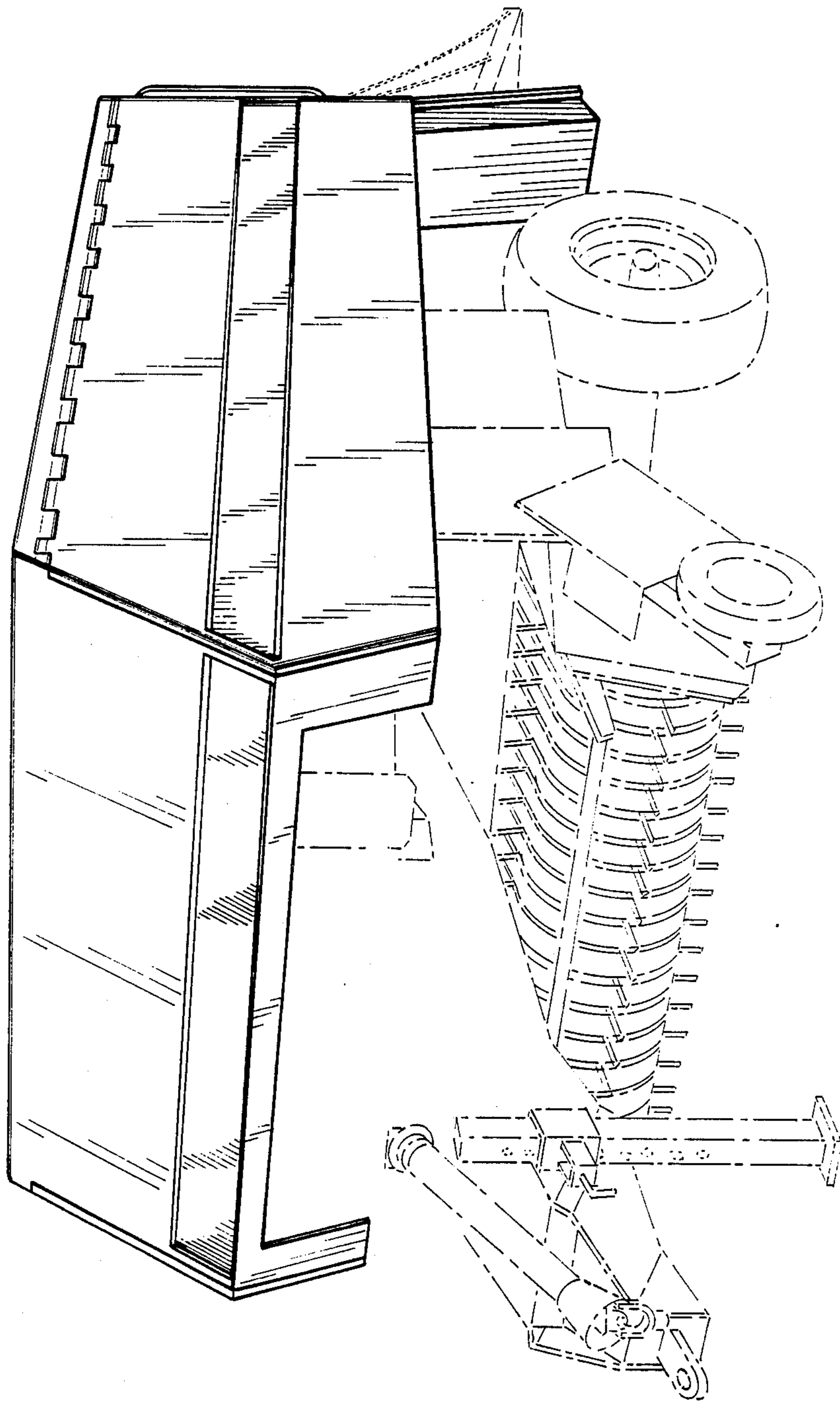

Fig. 2

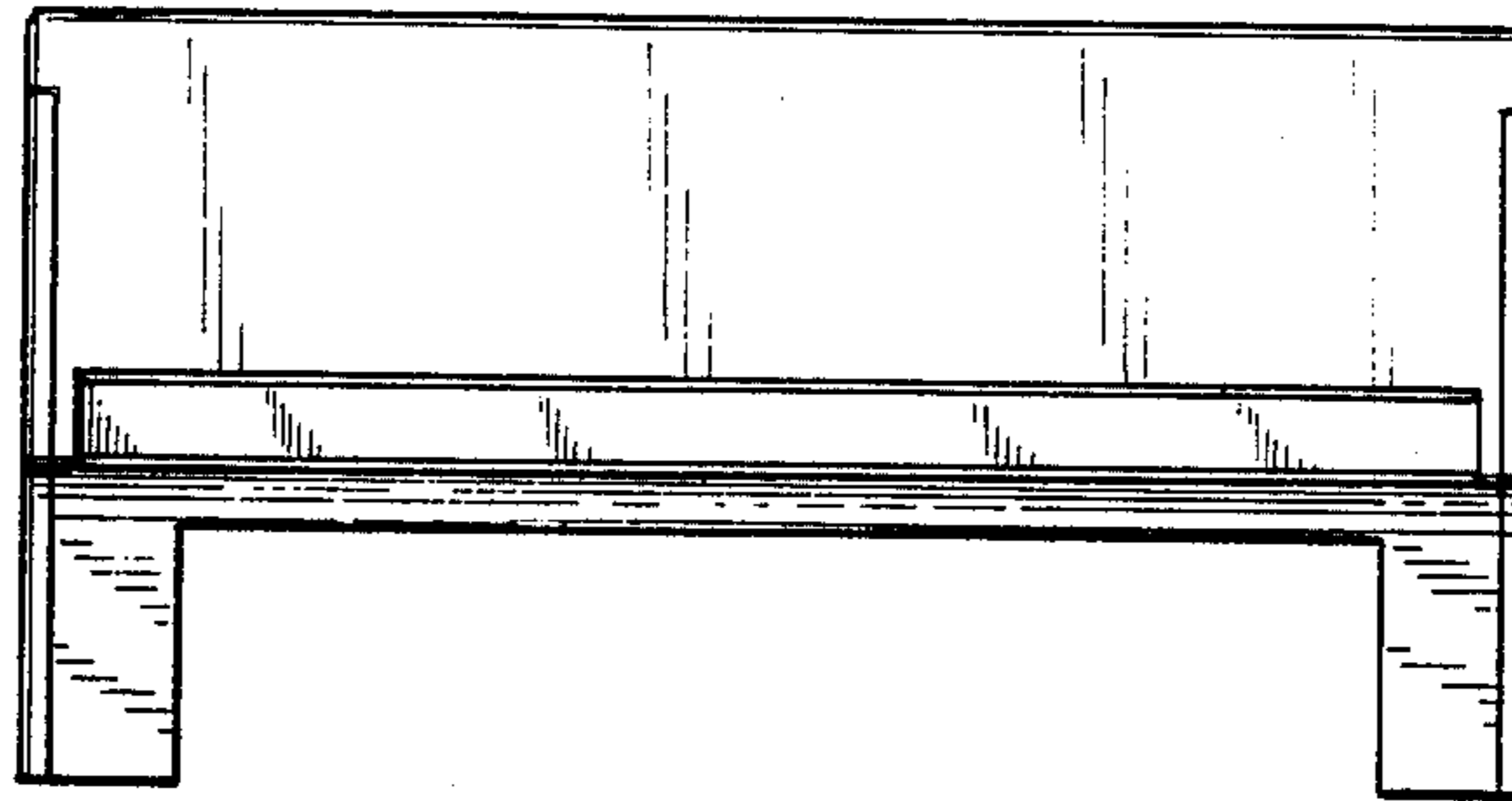

Fig. 3

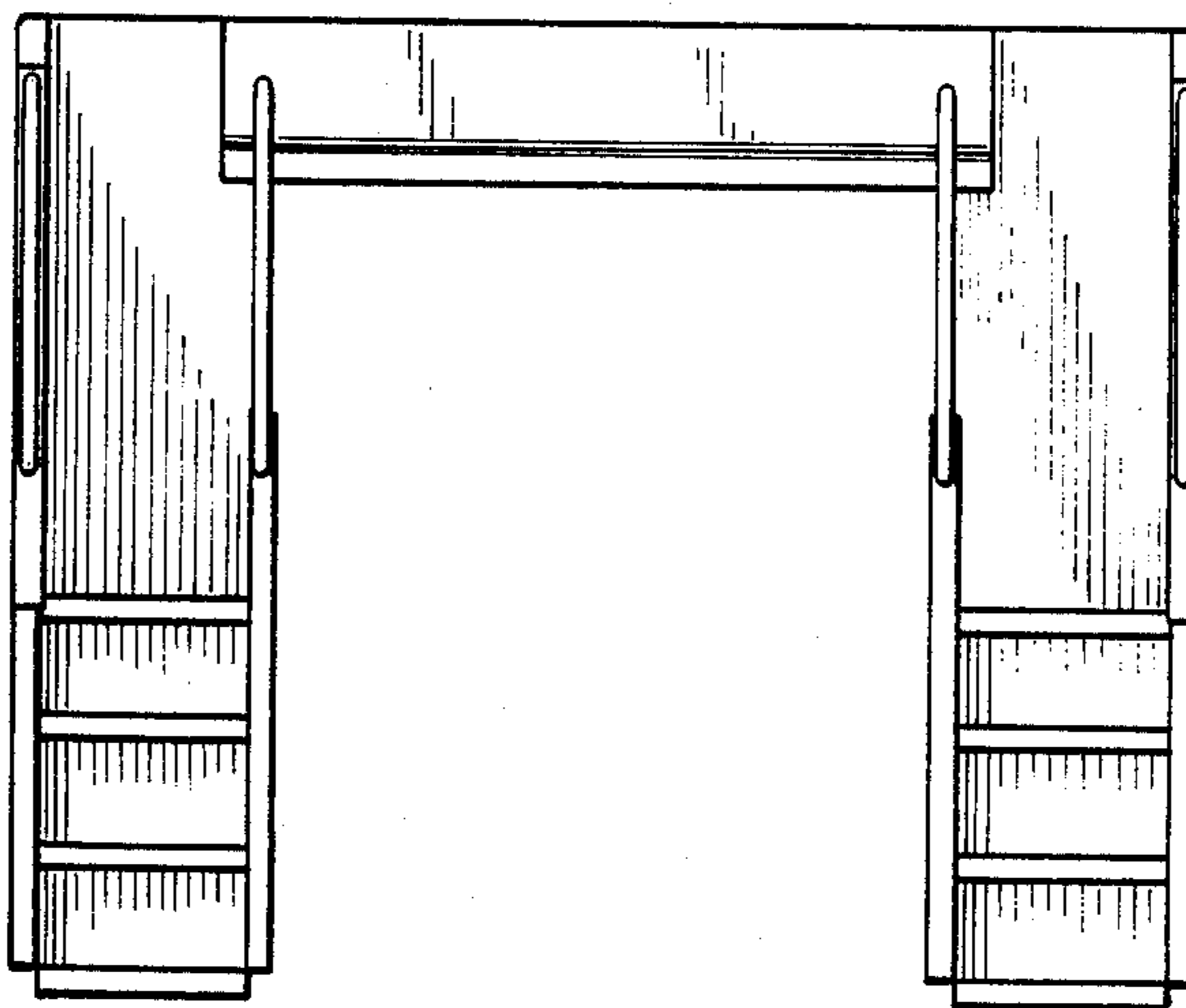

Fig. 4

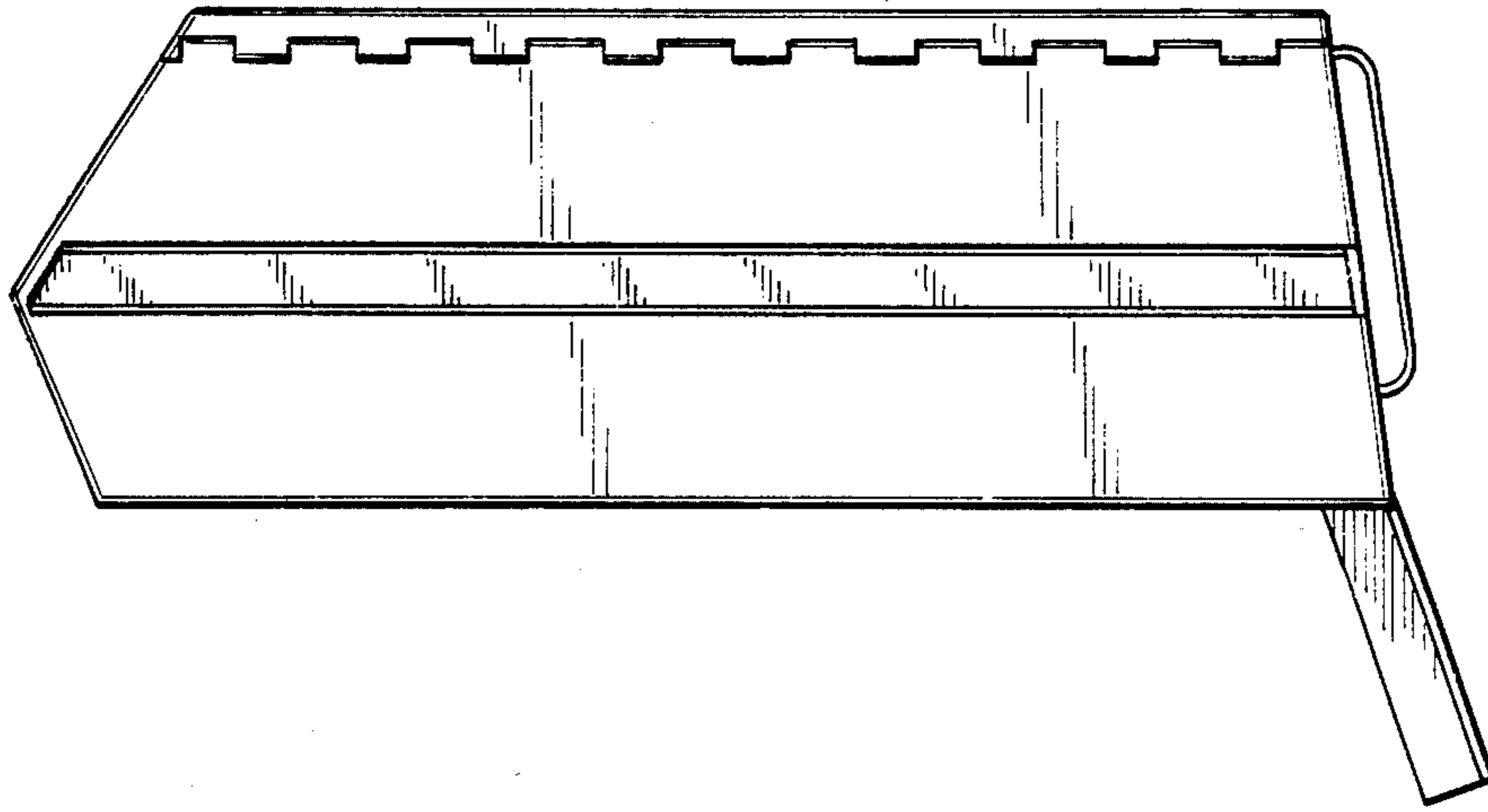

Fig. 5

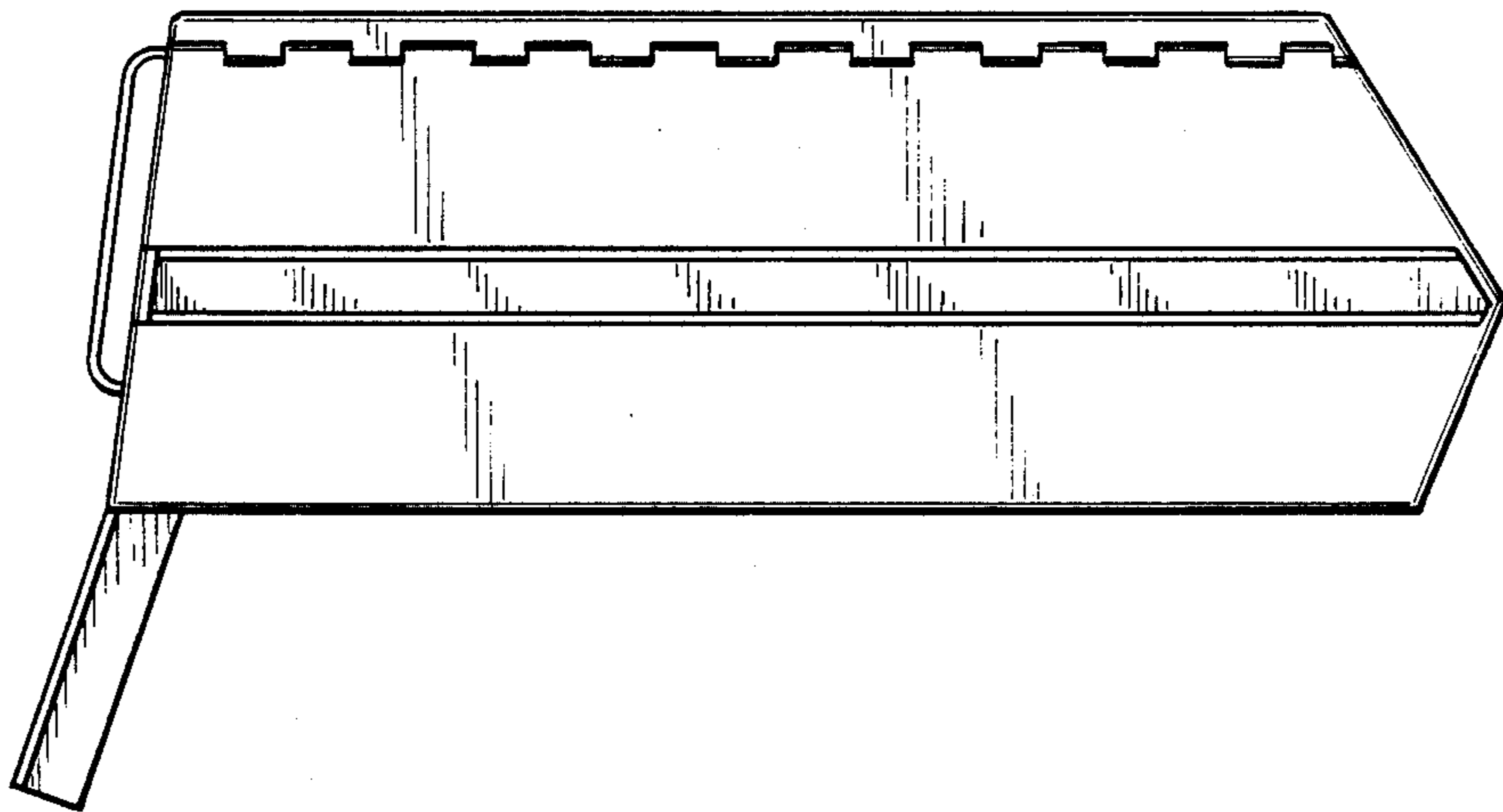

Fig. 6

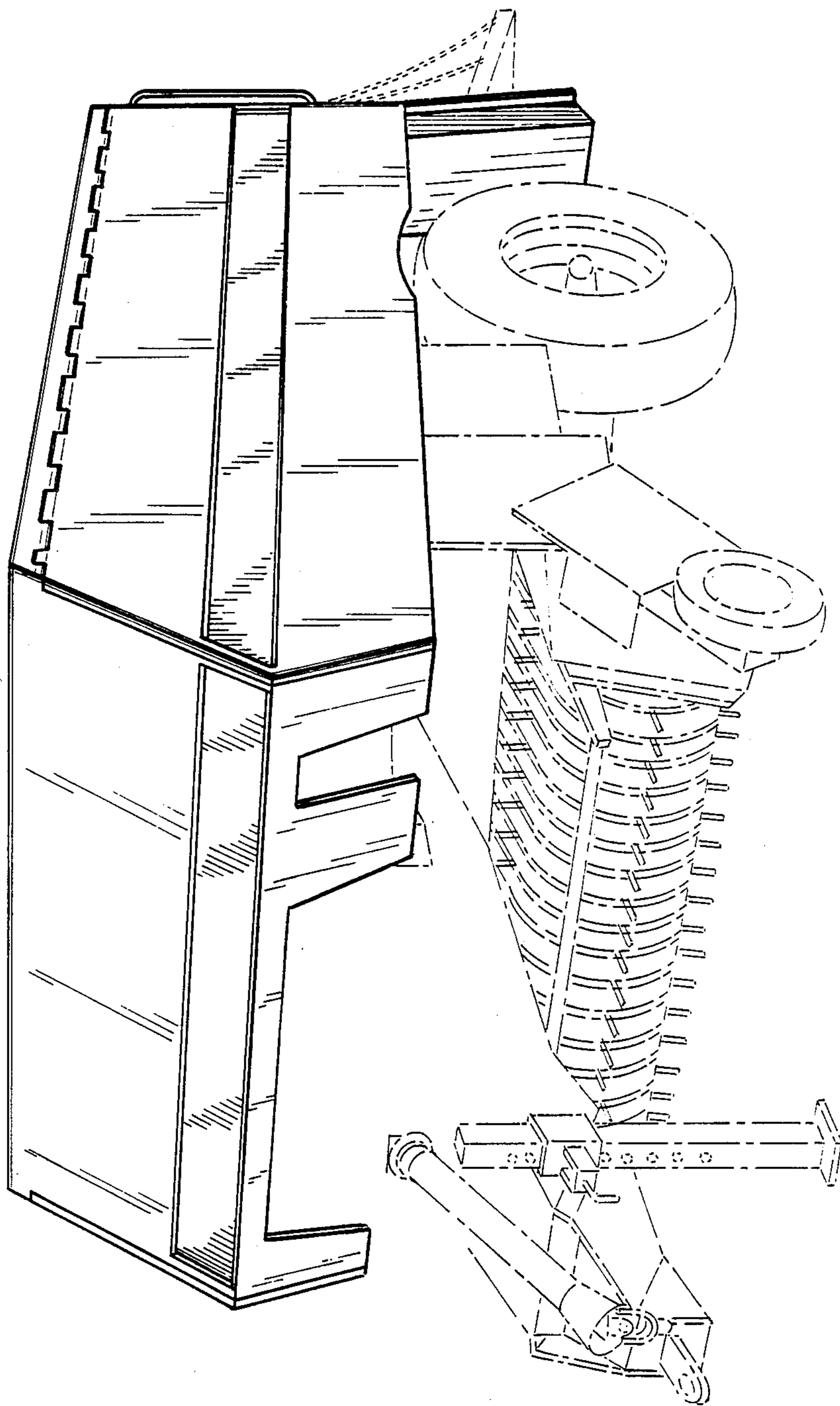

Fig. 7

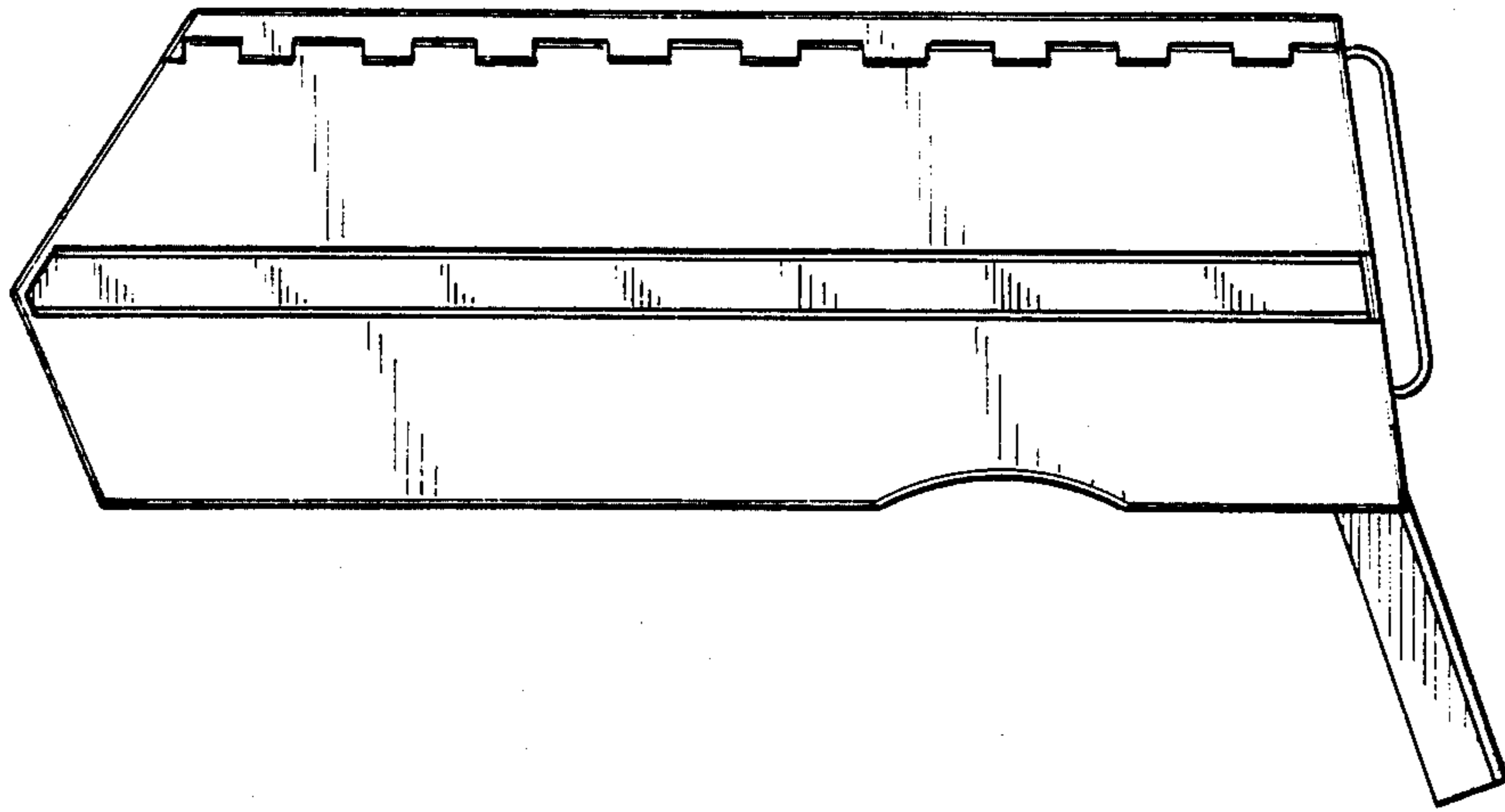

Fig. 8

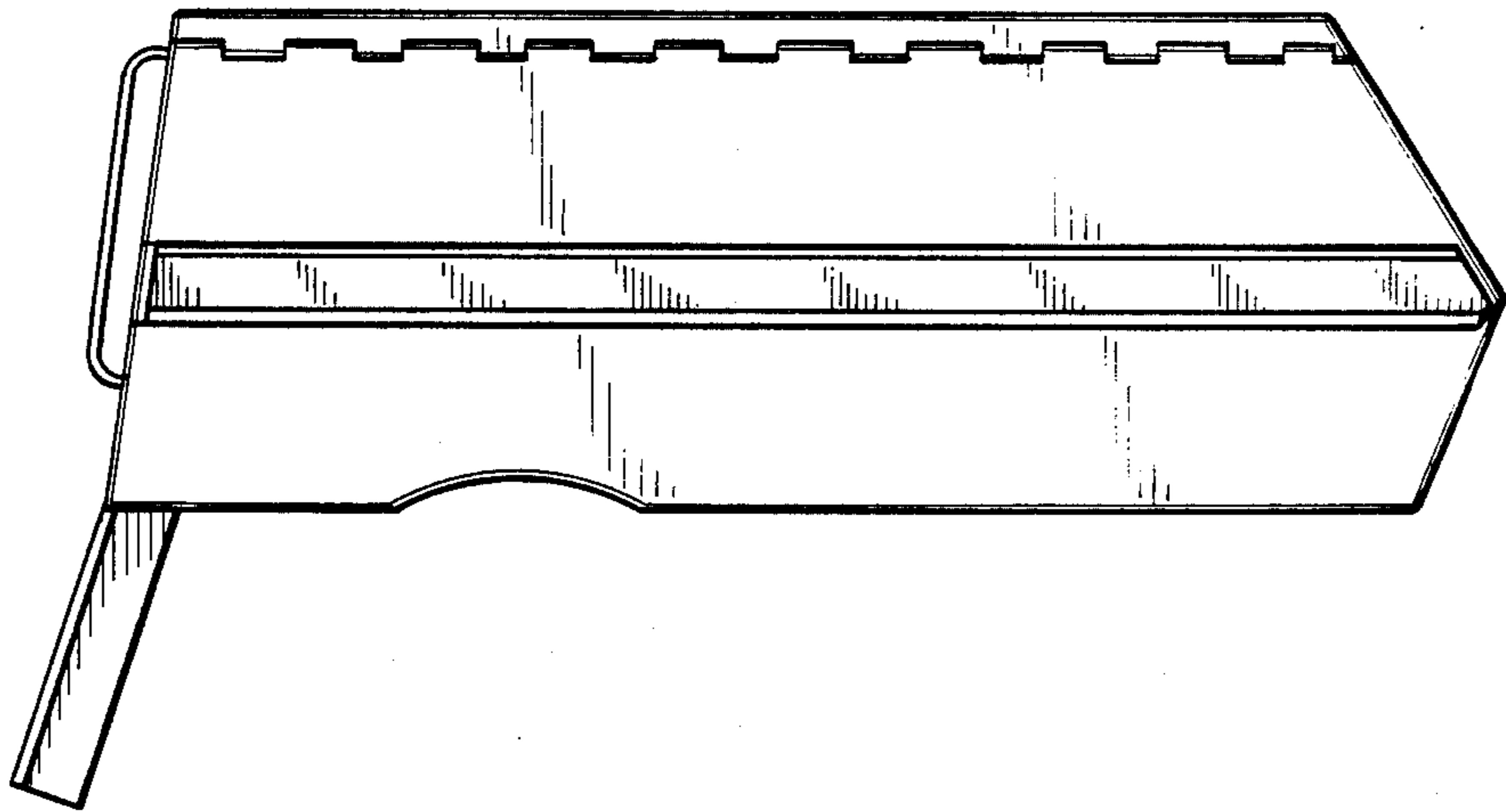

Fig. 9

