

[54] WHEEL BALANCER

[76] Inventor: Glennis W. Lasiter, R.R. 3, Box 186, Aurora, Mo. 65605

[**] Term: 14 Years

[21] Appl. No.: 838,051

[22] Filed: Feb. 28, 1986

[52] U.S. Cl. D10/82

[58] Field of Search D10/82; D15/199; 73/484, 482, 485; 301/5 B

[56] References Cited

U.S. PATENT DOCUMENTS

D. 160,327	10/1950	Lowe	D10/82
D. 210,769	7/1965	Rexroat	D10/82
D. 232,921	9/1974	Saulnier	D10/82
D. 277,651	2/1985	Herron	D10/82
915,718	3/1909	Bassett	.	
923,401	6/1909	Bassett	.	
923,402	6/1909	Bassett	.	
1,774,718	6/1927	McCabe	.	
2,136,633	5/1934	Morse	.	
2,265,897	12/1941	De Ghetto	.	
2,816,446	12/1957	Palmer	.	

3,280,640	10/1966	Fuertges	73/484
3,888,128	6/1975	Mitchell	73/484
3,916,696	11/1975	Mitchell	73/484
3,921,462	11/1975	Hamer	.	
4,046,018	9/1977	Lasiter	.	

FOREIGN PATENT DOCUMENTS

177509 3/1921 United Kingdom .

Primary Examiner—B. J. Bullock

Attorney, Agent, or Firm—Henderson & Sturm

[57] CLAIM

The ornamental design for a wheel balancer, as shown herein.

DESCRIPTION

FIG. 1 is a left, front elevational view of a wheel balancer showing my new designs; FIG. 2 is a right, front elevational view taken in the direction of the arrows on line 2—2 of FIG. 1; FIG. 3 is a left, rear elevational view taken in the direction of the arrows on line 3—3 of FIG. 1; FIG. 4 is a right, rear elevational view taken in the direction of the arrows on lines 4—4 of FIG. 2; FIG. 5 is a top plan view thereof; and FIG. 6 is a bottom plan view thereof.

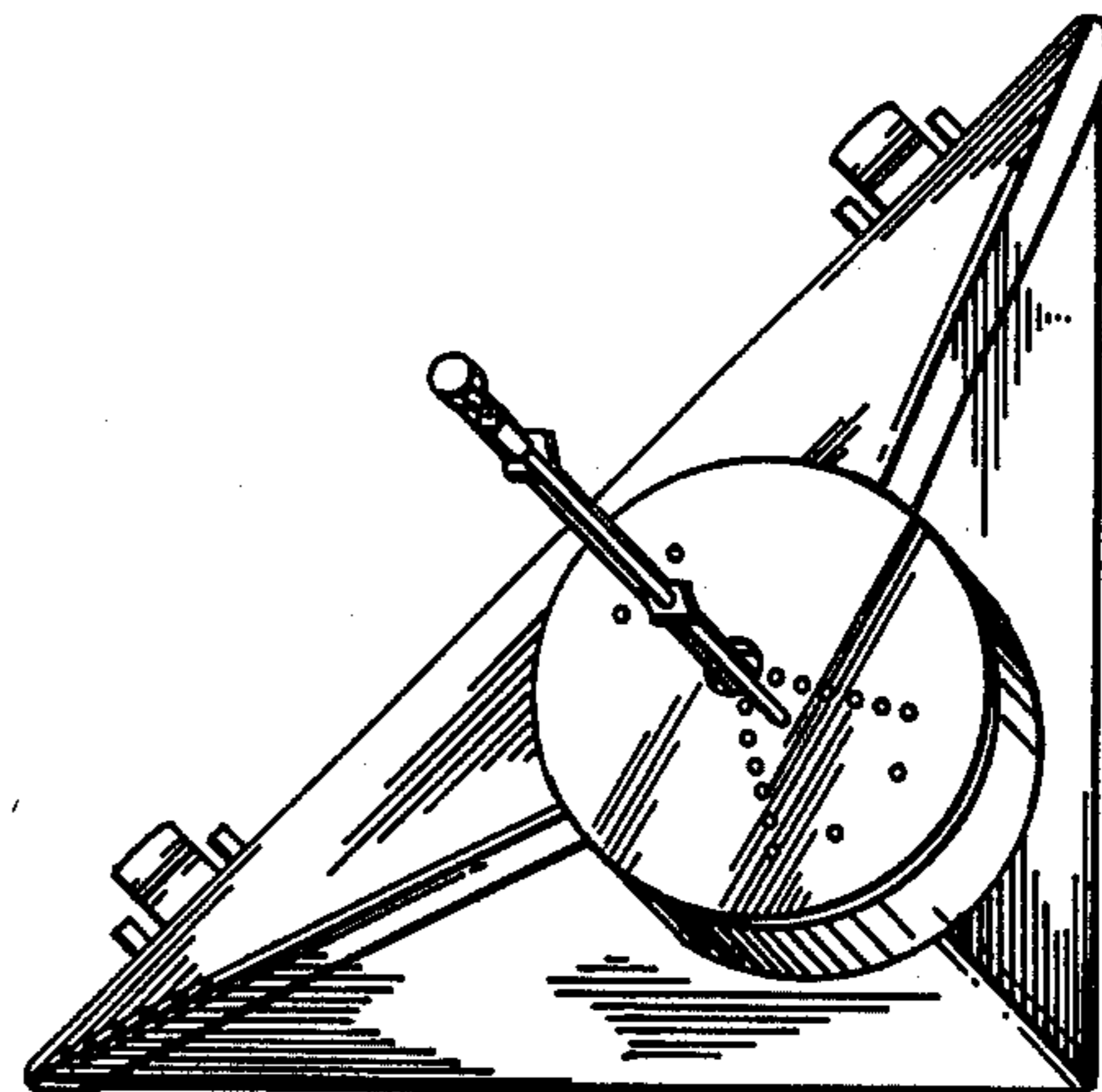
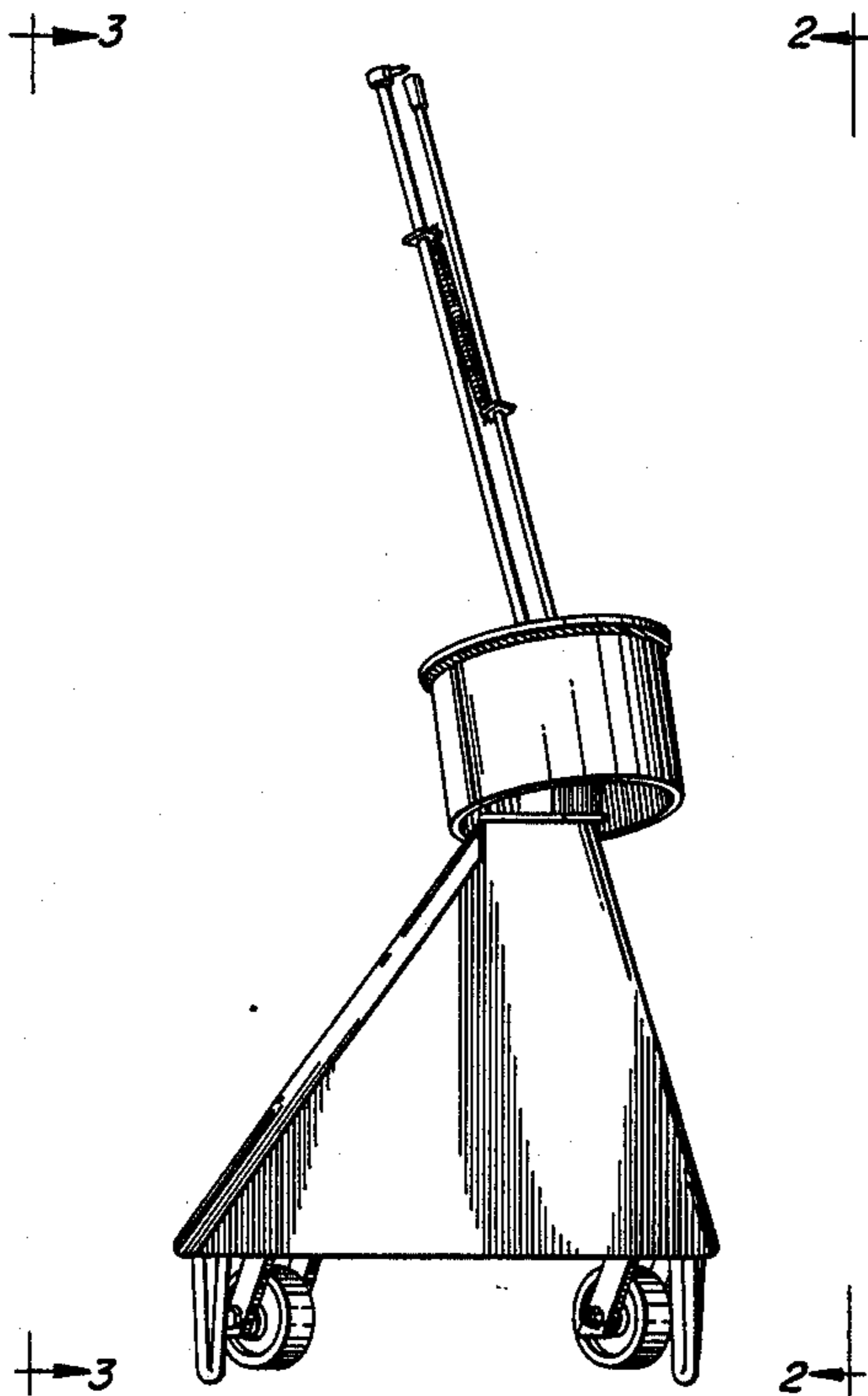

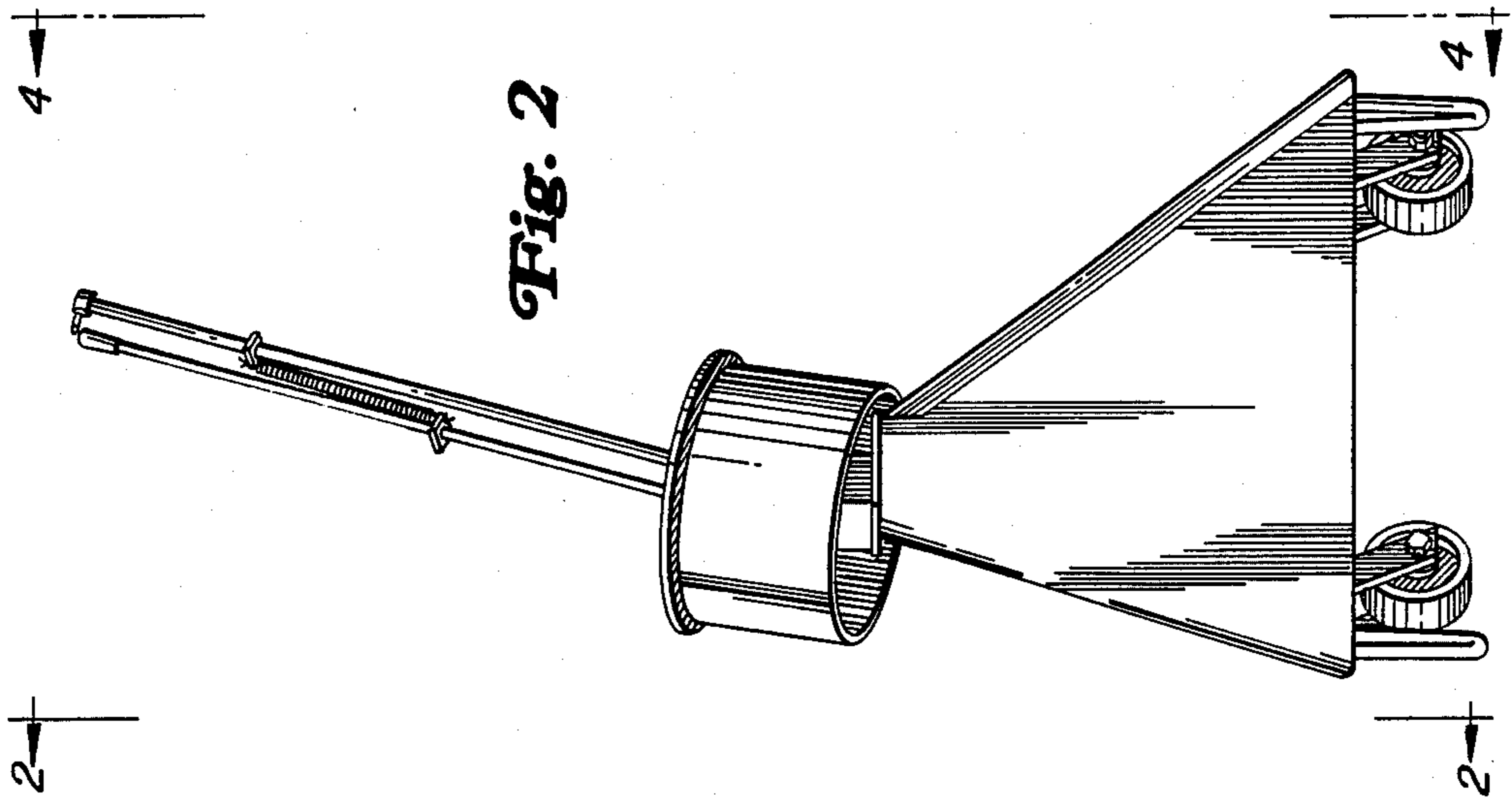

Fig. 1

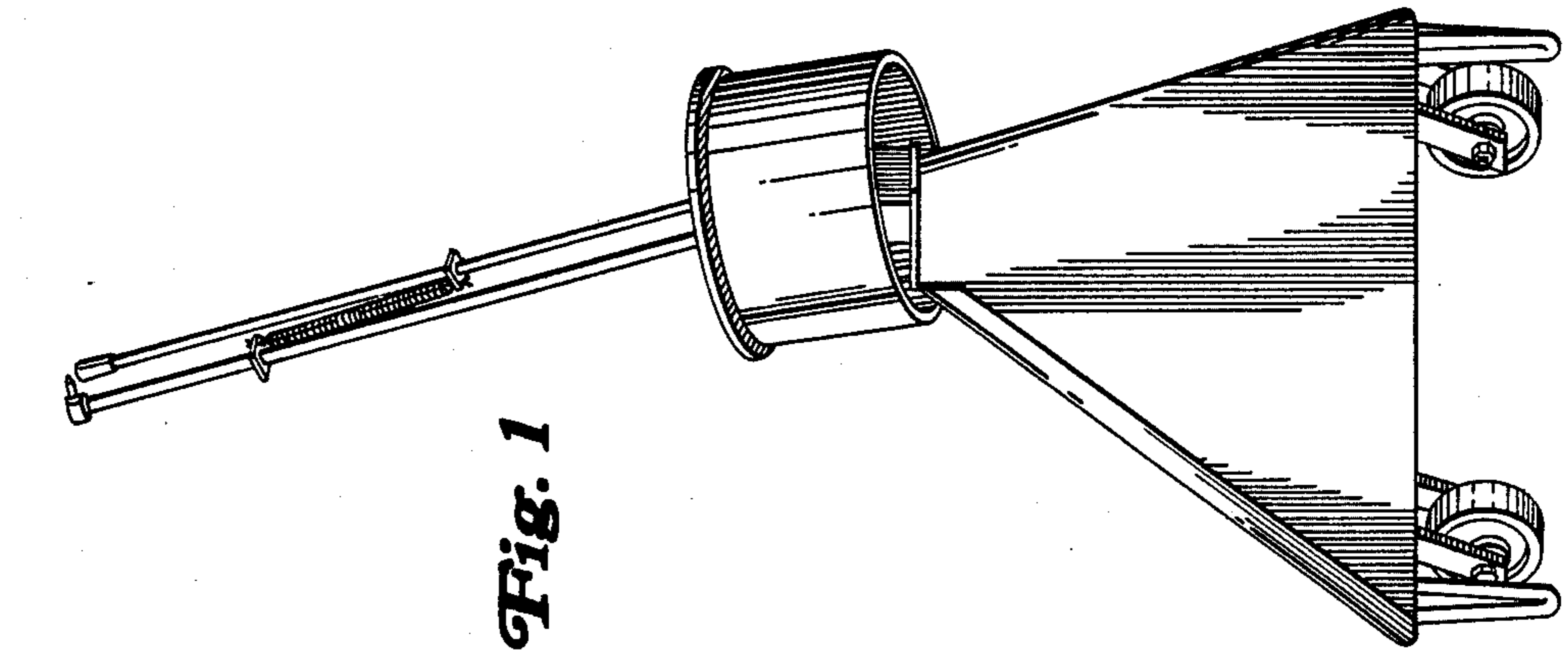

Fig. 2

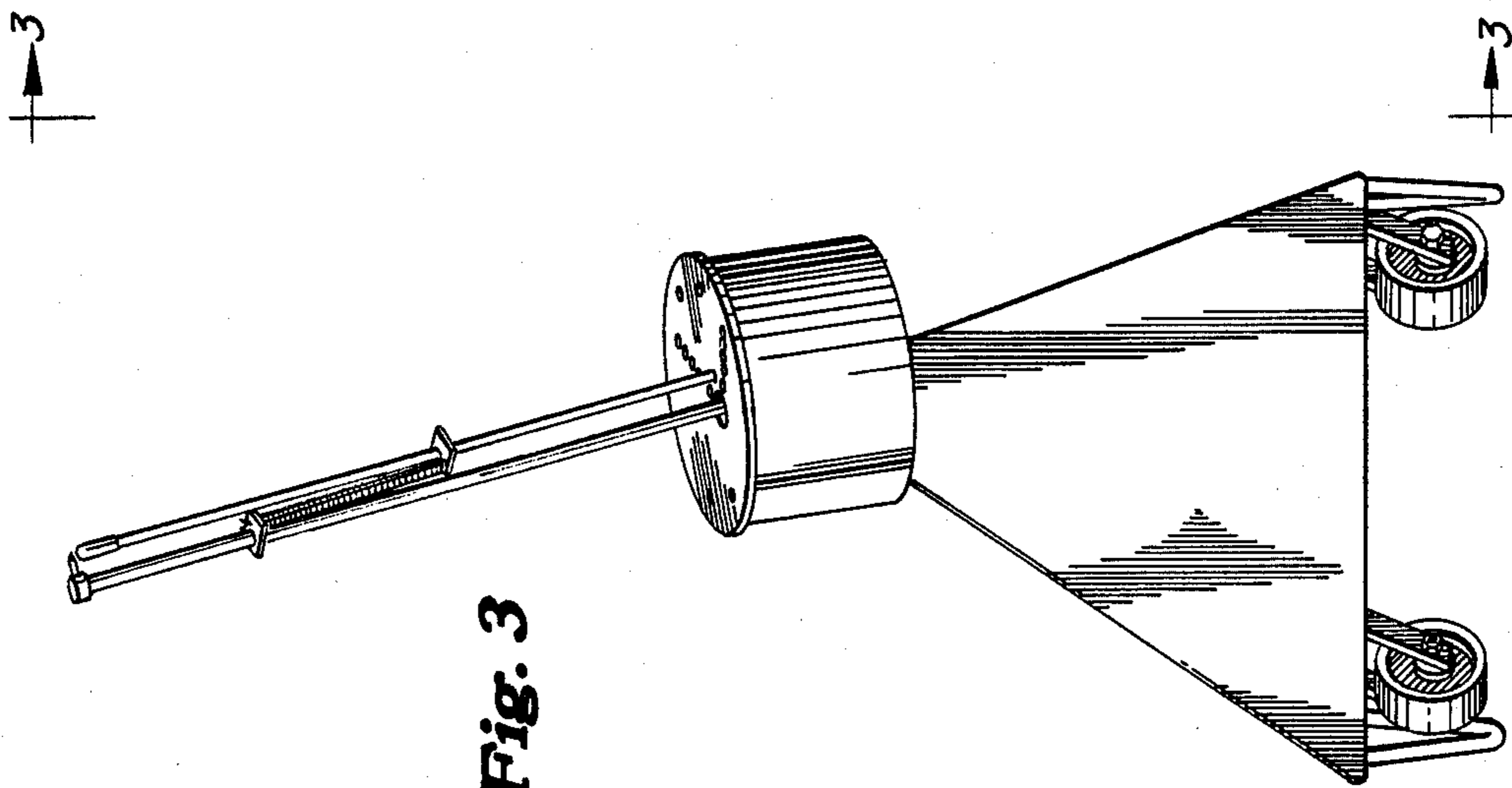

Fig. 3

Fig. 4

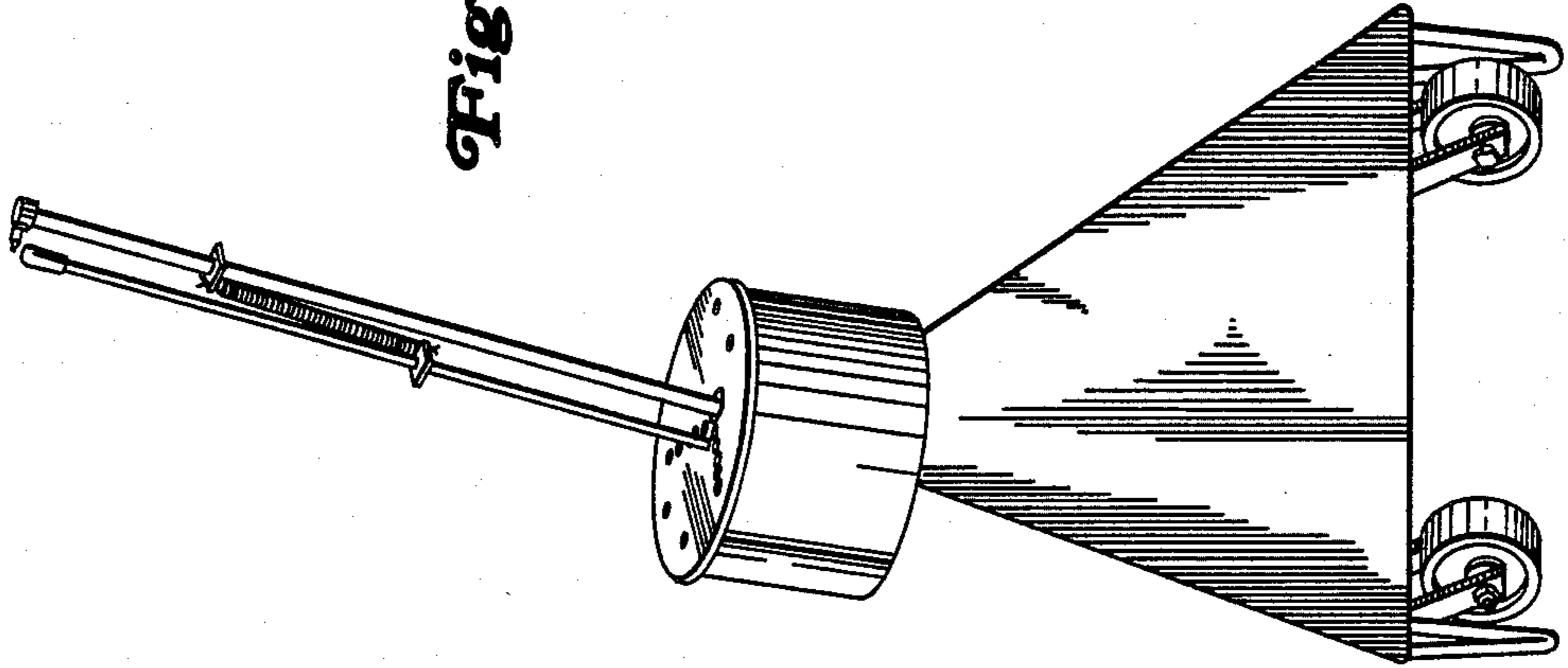

Fig. 5

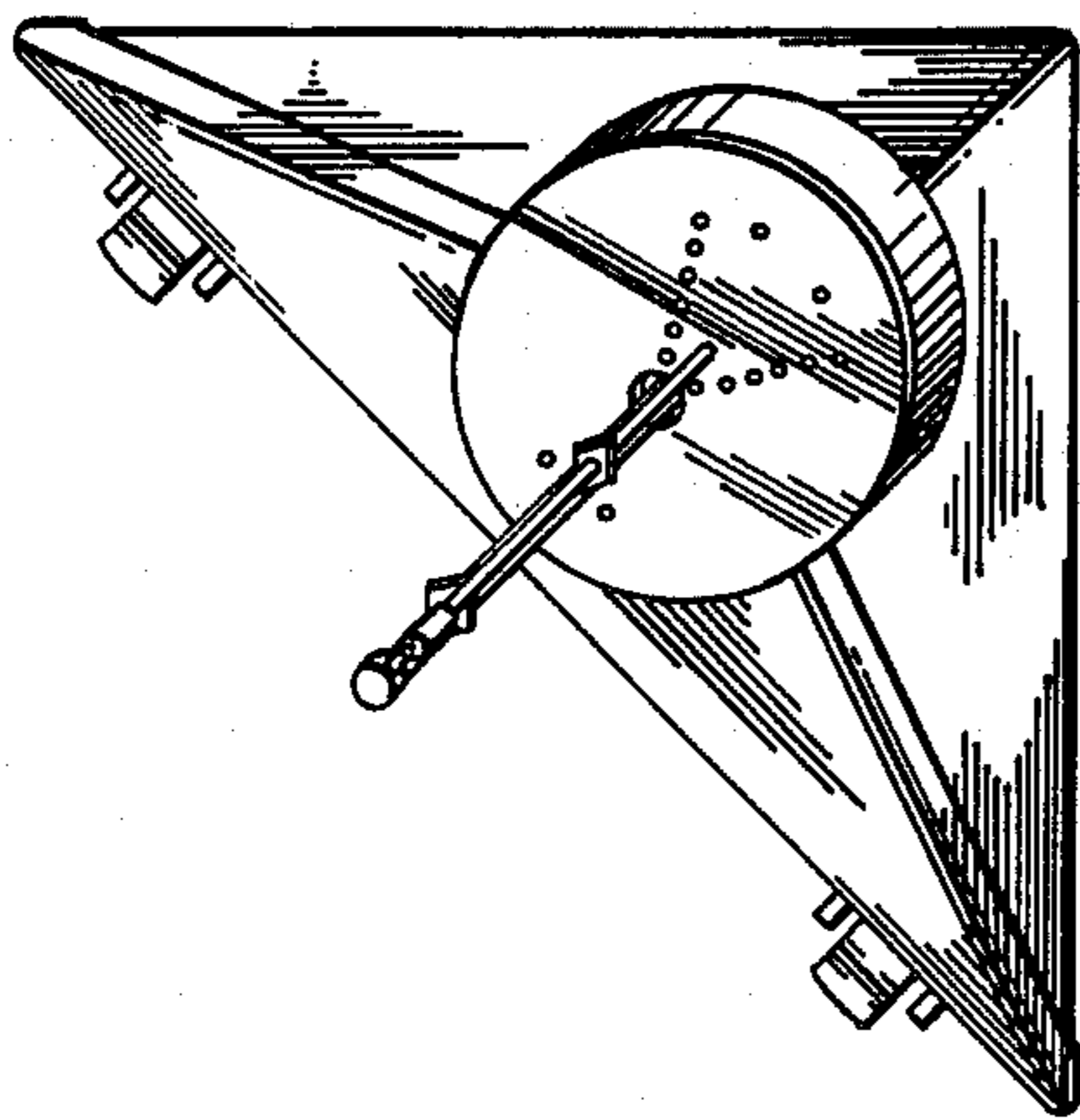

Fig. 6

