

United States Patent [19]

Hoke

[11] Patent Number: Des. 298,209

[45] Date of Patent: ** Oct. 25, 1988

[54] **HOLD-DOWN CLAMP FOR WELDING**

[75] Inventor: **Thomas A. Hoke, R.D. #2, Red Lion, Pa. 17356**

[73] Assignees: **Thomas A. Hoke; Phyllis V. Hoke, both of Red Lion, Pa.**

[**] Term: **14 Years**

[21] Appl. No.: **765,681**

[22] Filed: **Aug. 15, 1985**

[52] U.S. Cl. **D8/72**

[58] Field of Search **D8/71-74, D8/14; 269/8, 49, 41, 152, 155, 50**

[56] **References Cited**

U.S. PATENT DOCUMENTS

D. 272,311 1/1984 Bell et al. **D8/71**

1,343,346 6/1920 Buckley 269/8
3,770,259 11/1973 Wagreich D8/72 X
3,827,682 8/1974 Foster, Sr. et al. 269/8
4,300,754 11/1981 Lawrence 269/8

Primary Examiner—Susan J. Lucas
Assistant Examiner—Clare E. Heflin
Attorney, Agent, or Firm—Charles J. Long

[57] **CLAIM**

The ornamental design for a hold-down clamp for welding, as shown and described.

DESCRIPTION

FIG. 1 is front elevational view of a hold-down clamp for welding showing my new design; FIG. 2 is a top plan view thereof; FIG. 3 is rear elevational view thereof; and FIG. 4 is an end elevational view thereof.

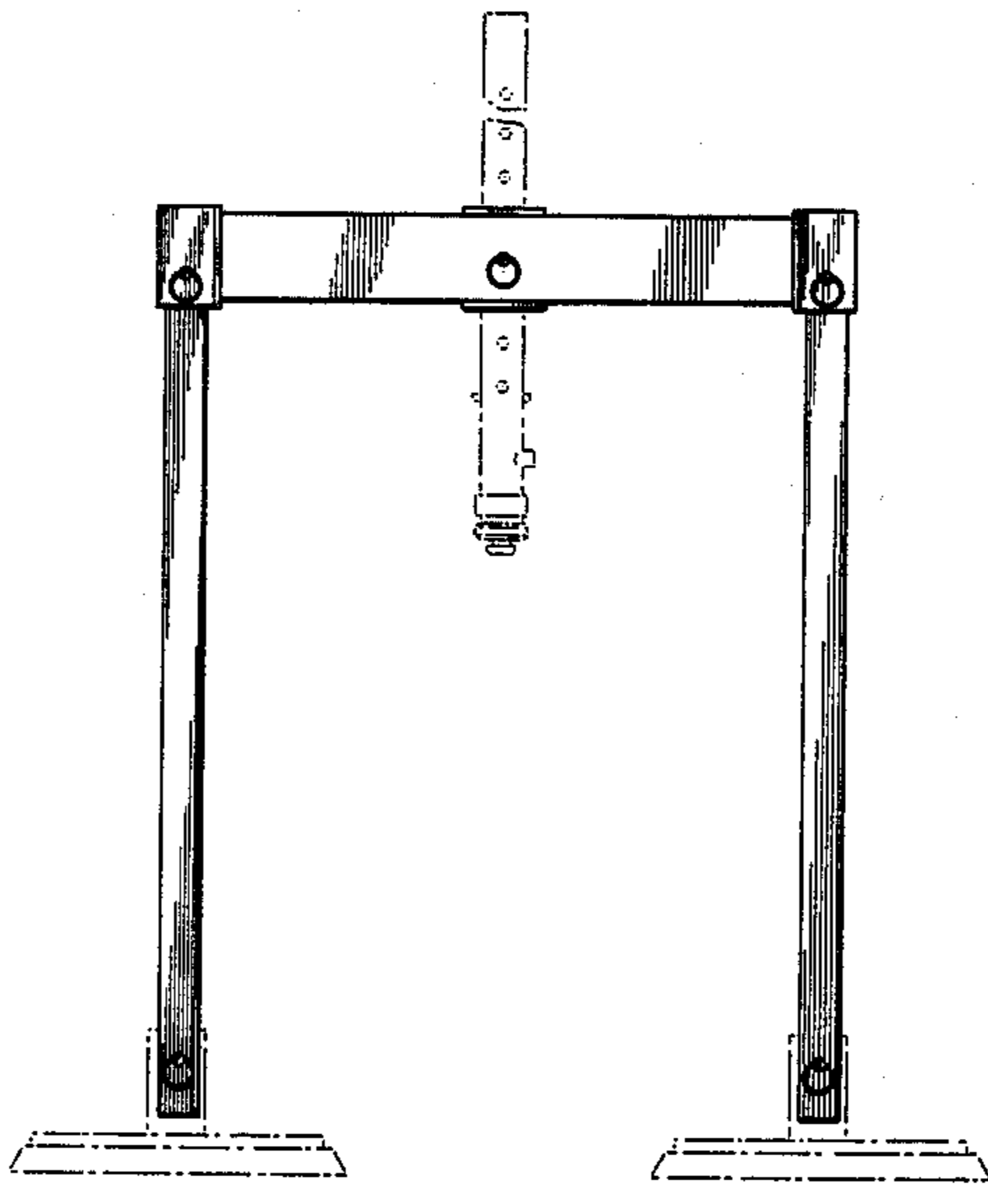

Fig. 1

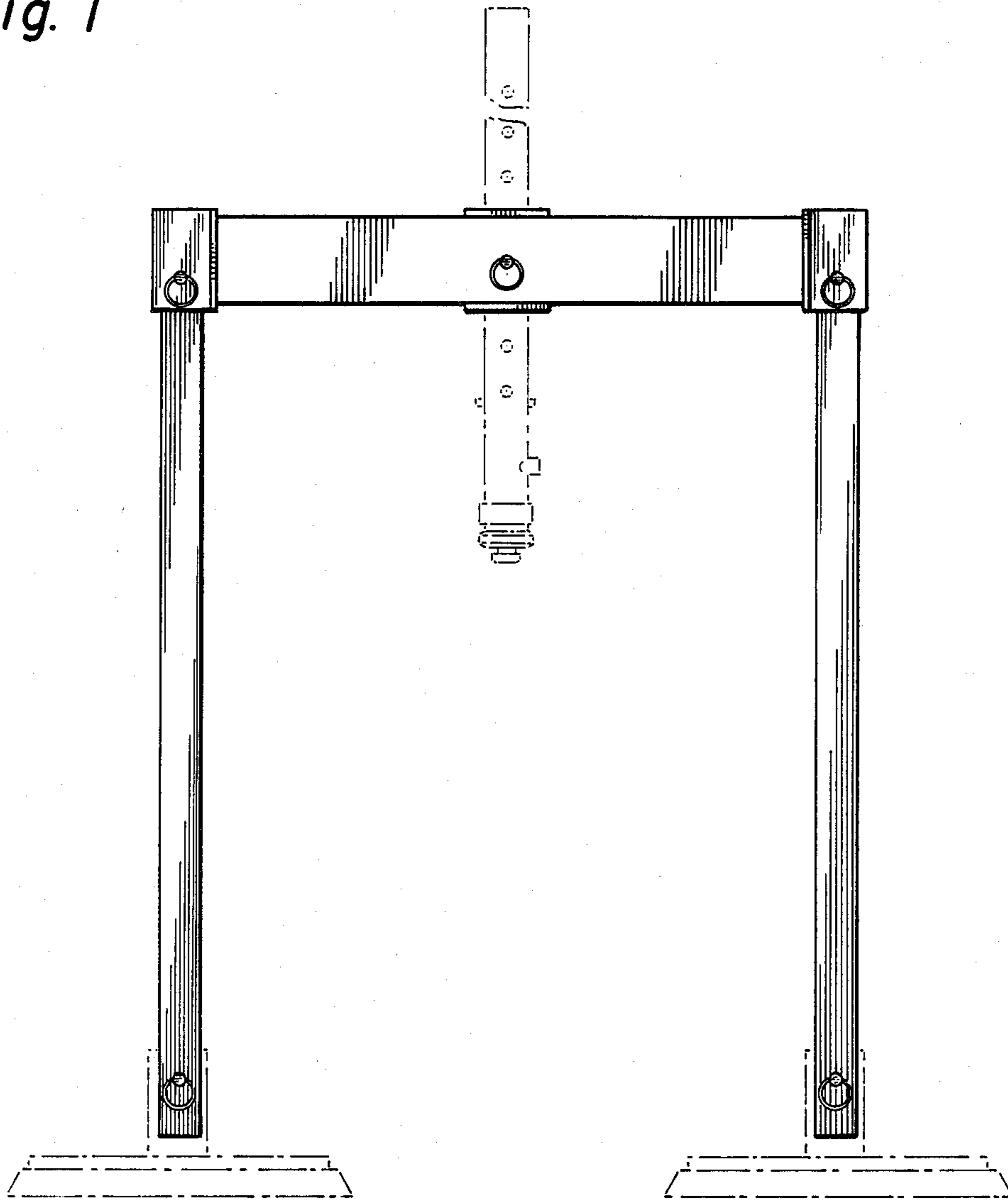
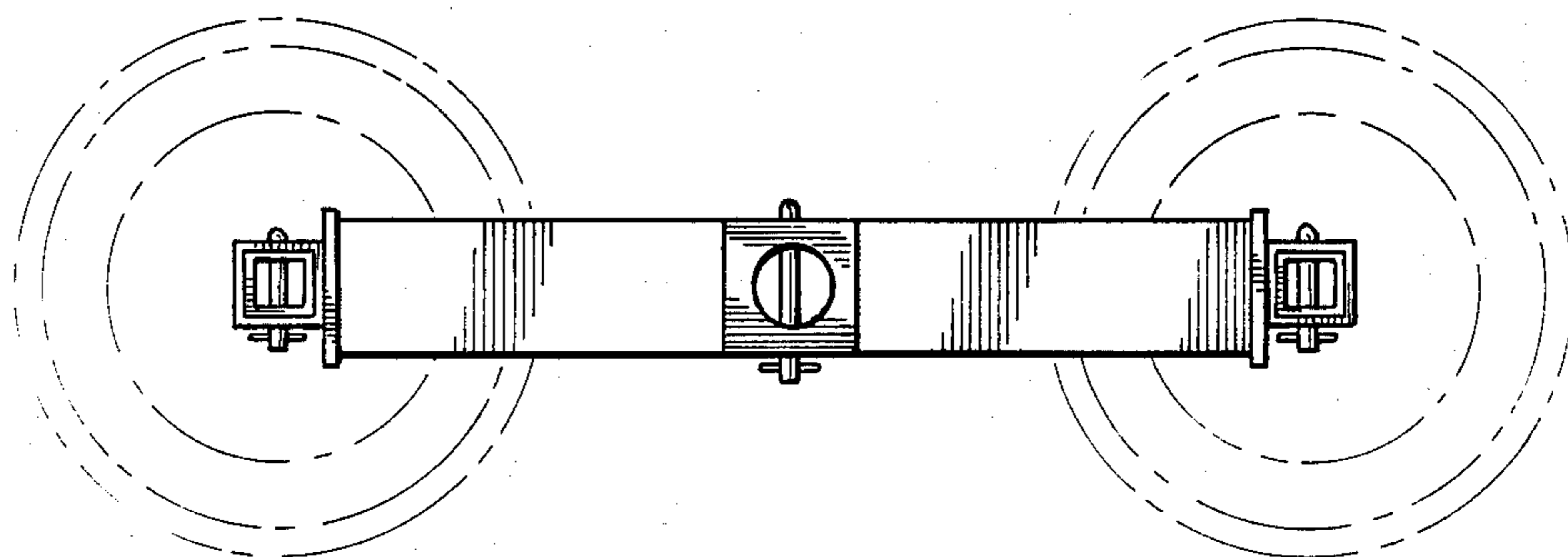

Fig. 2



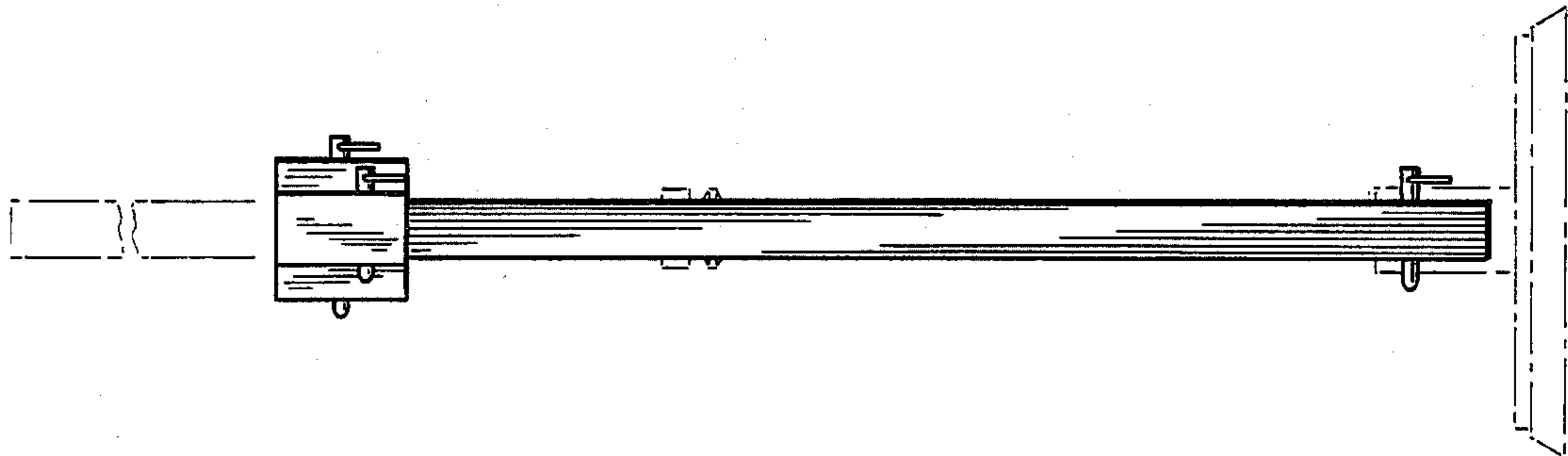

Fig. 4

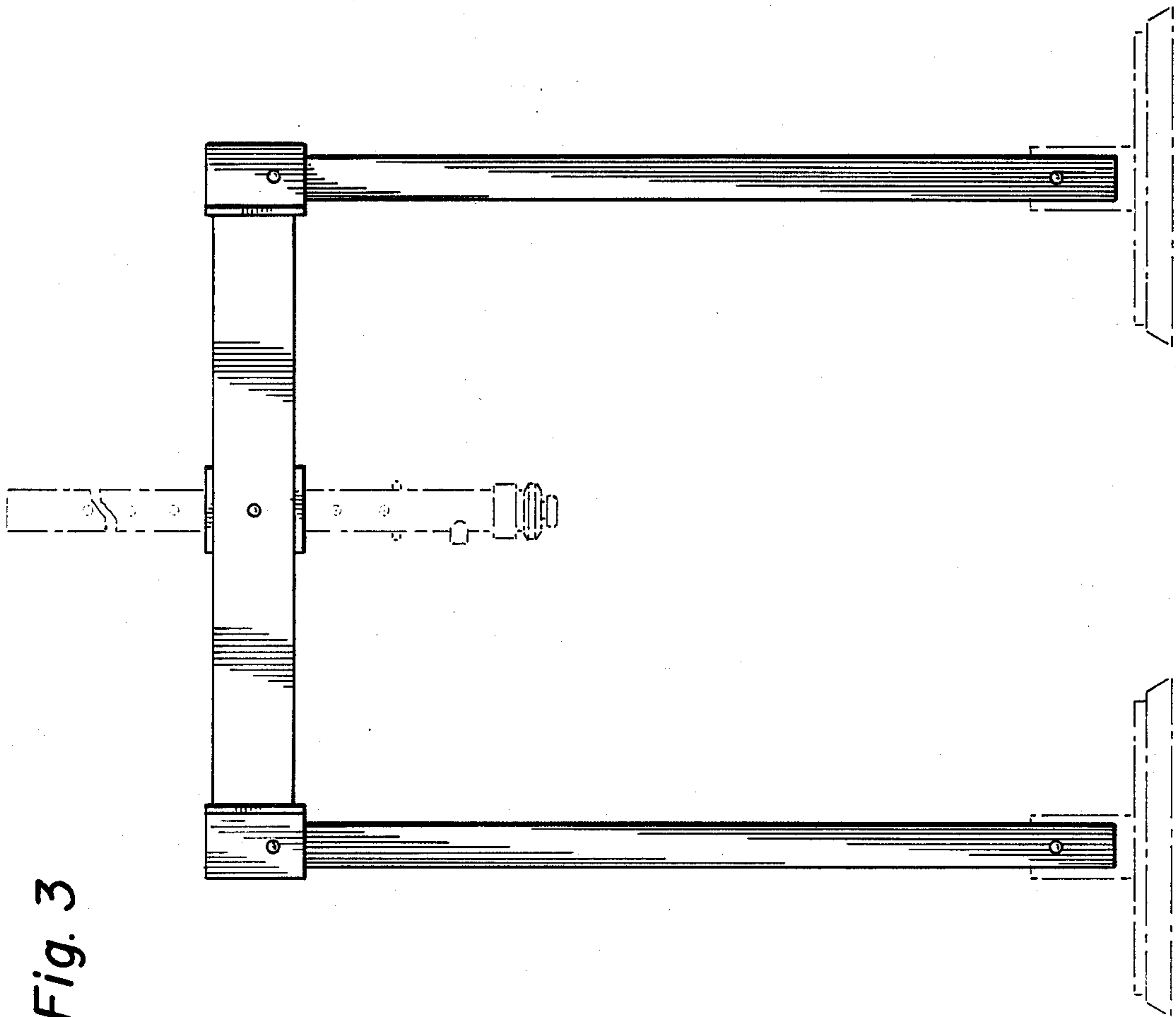

Fig. 3