

# United States Patent [19]

Tamura et al.

[11] Patent Number: **Des. 298,113**

[45] Date of Patent: **\*\* Oct. 18, 1988**

[54] **FOUR-WHEELED MOTORCYCLE**

[75] Inventors: **Gen Tamura, Tokyo; Kazuhiko Yokoyama; Yoshiharu Hashimoto,** both of Saitama, all of Japan

[73] Assignee: **Honda Giken Kogyo Kabushiki Kaisha, Tokyo, Japan**

[\*\*] Term: **14 Years**

[21] Appl. No.: **895,055**

[22] Filed: **Aug. 11, 1986**

[30] **Foreign Application Priority Data**

Feb. 14, 1986 [JP] Japan ..... 61-4925  
[52] U.S. Cl. .... **D12/107**  
[58] Field of Search ..... **D12/107, 110, 3;**  
**180/219, 225, 229, 233, 311, 312**

[56] **References Cited**

**U.S. PATENT DOCUMENTS**

D. 285,058 8/1986 Takagaki ..... D12/3  
D. 285,424 9/1986 Hishinuma ..... D12/3  
4,667,758 5/1987 Tamura ..... 180/229

*Primary Examiner*—James M. Gandy  
*Attorney, Agent, or Firm*—Lyon & Lyon

[57] **CLAIM**

The ornamental design for a four-wheeled motorcycle, as shown.

**DESCRIPTION**

FIG. 1 is a front elevation view of a four-wheeled motorcycle showing our new design;  
FIG. 2 is a rear elevation view thereof;  
FIG. 3 is an elevation view of the left side thereof;  
FIG. 4 is an elevation view of the right side thereof;  
FIG. 5 is a top plan view thereof; and  
FIG. 6 is a perspective view thereof.

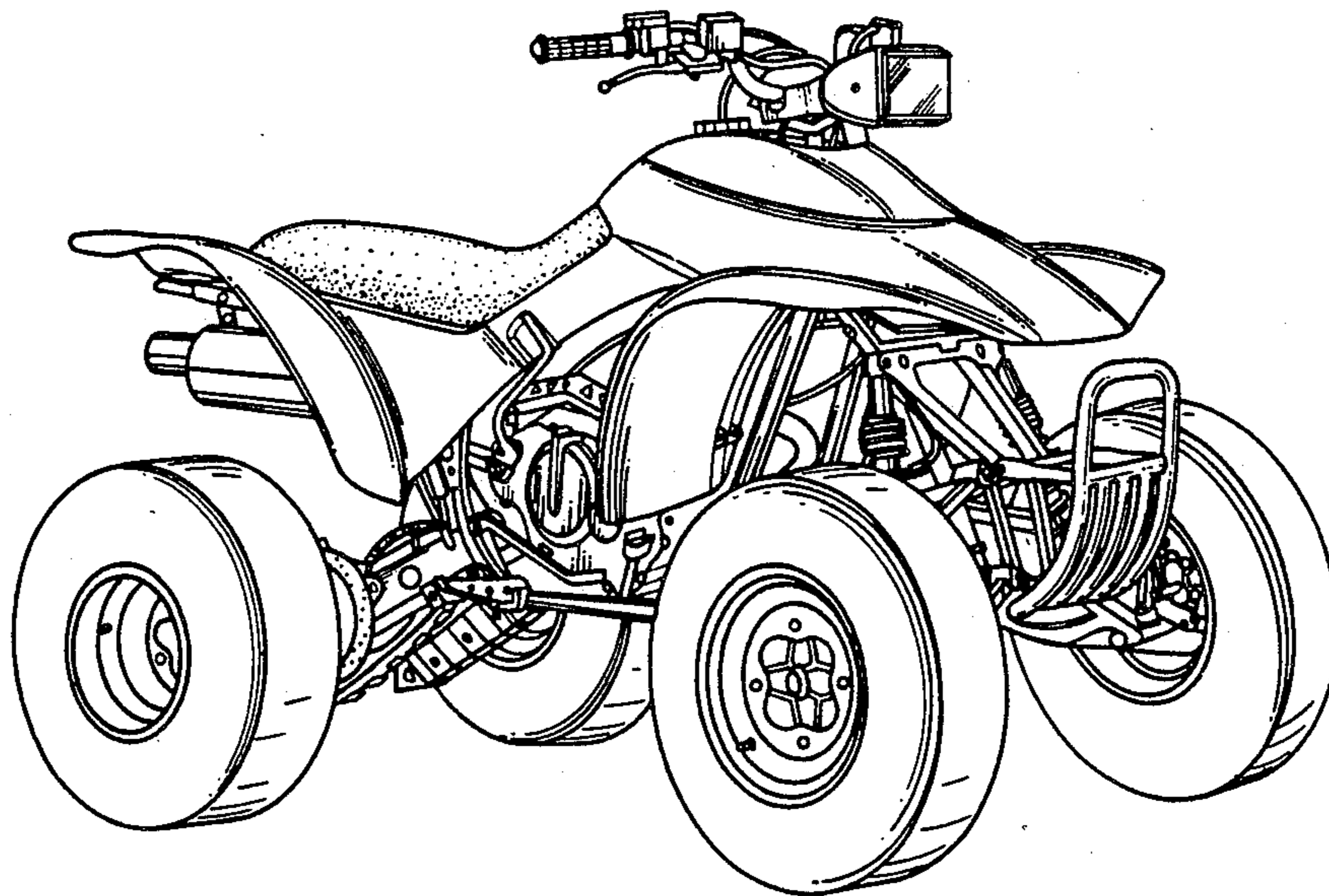

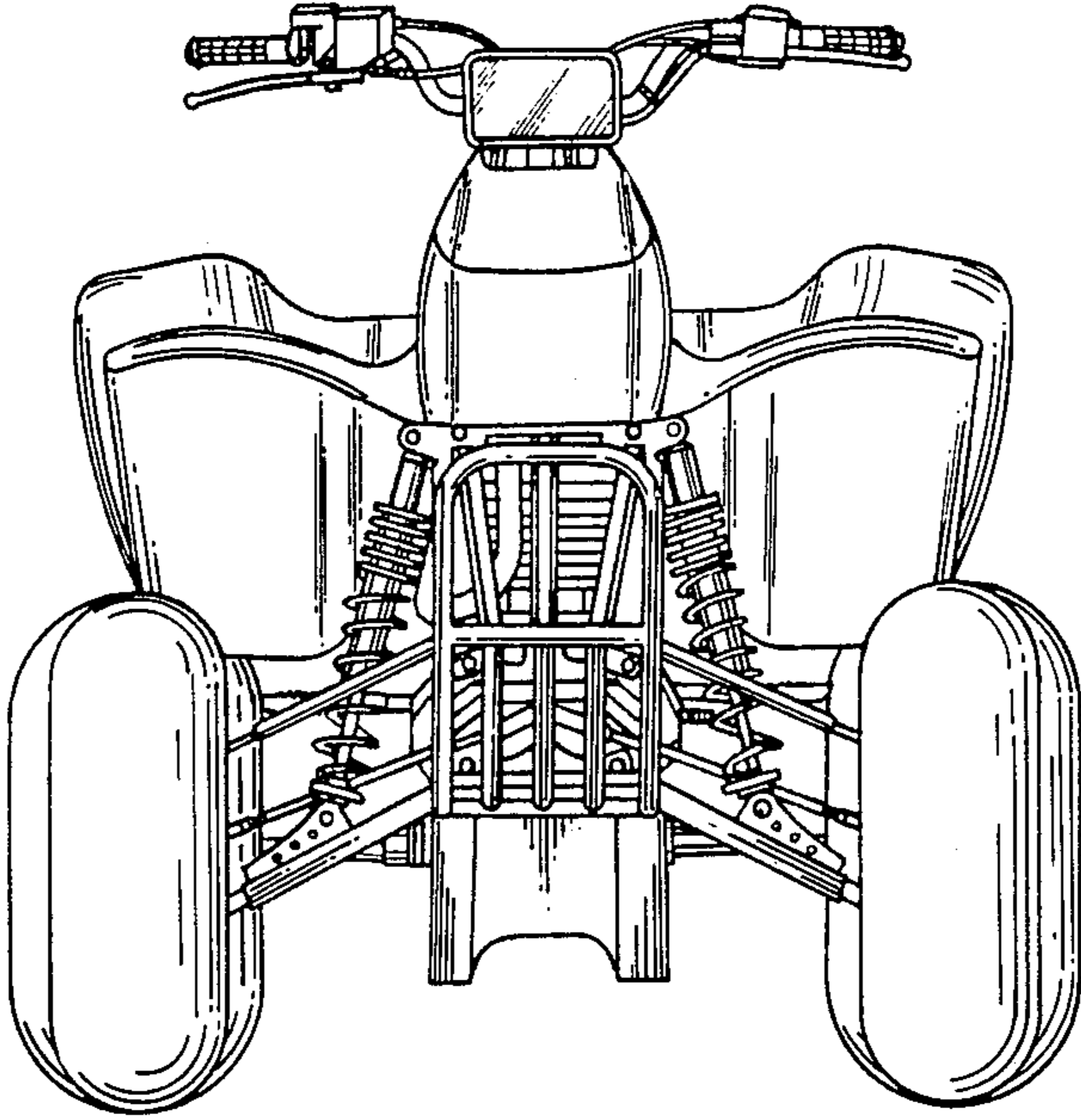

*FIG. 1.*

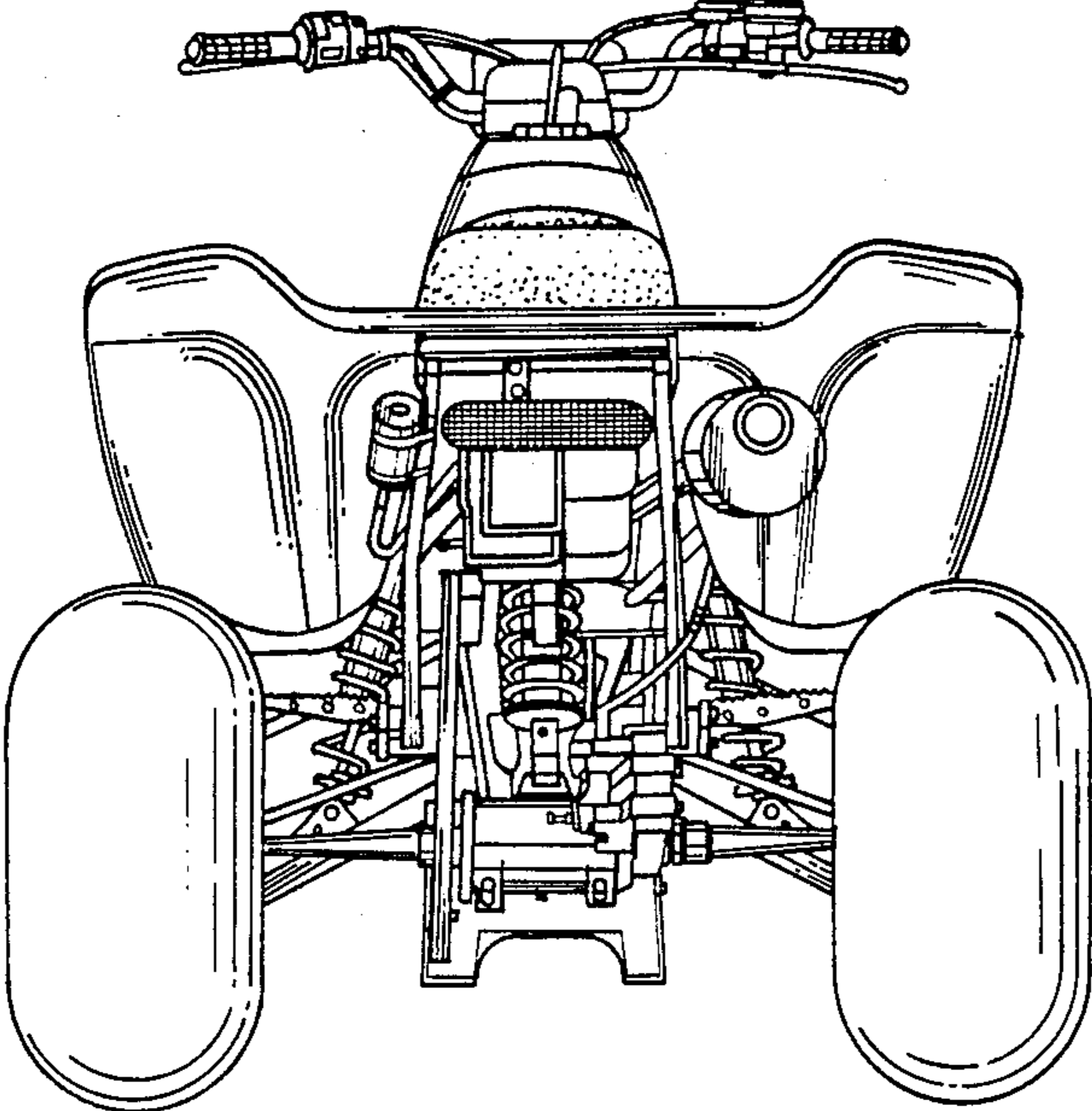

*FIG. 2*



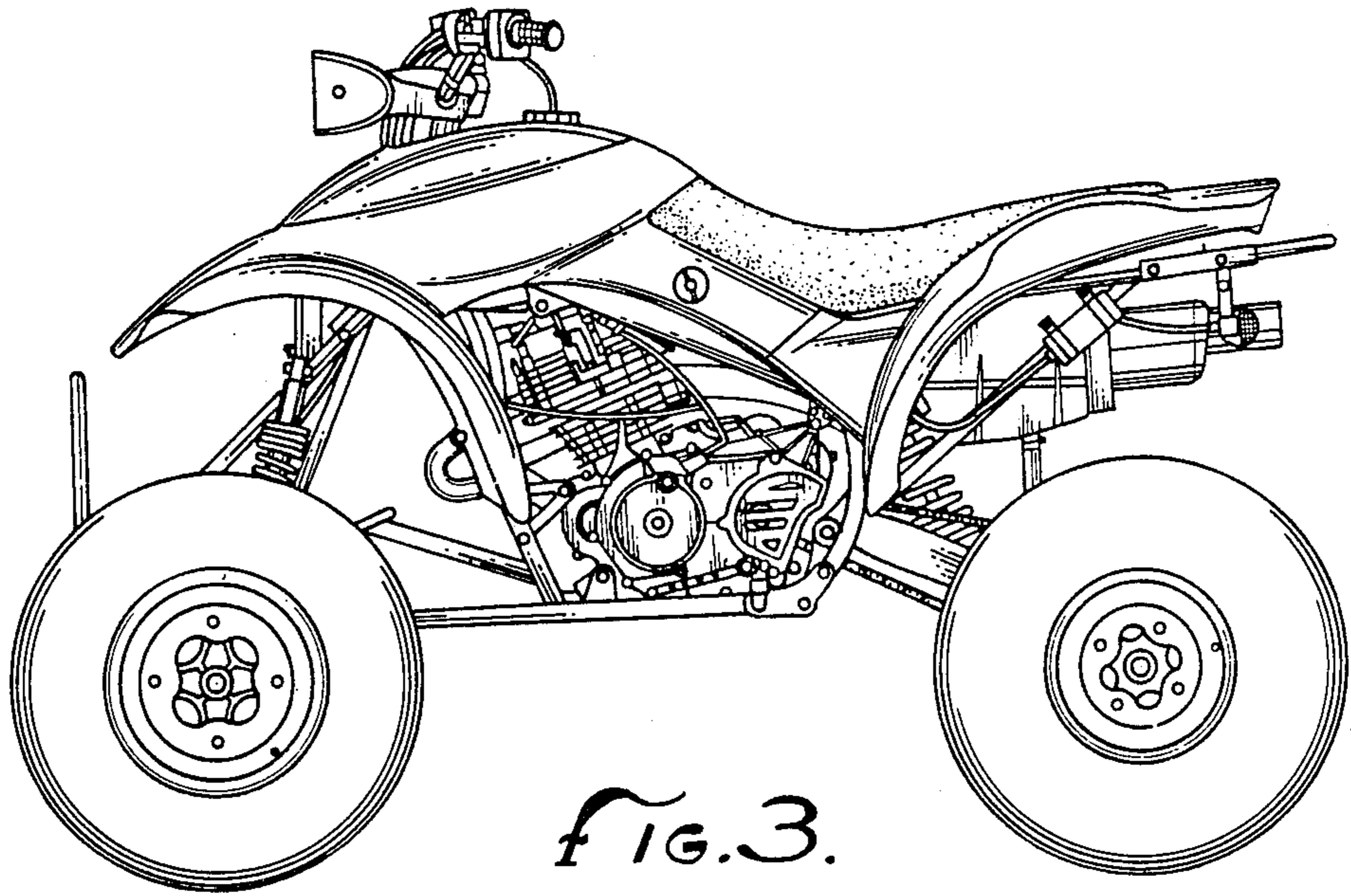

FIG. 3.

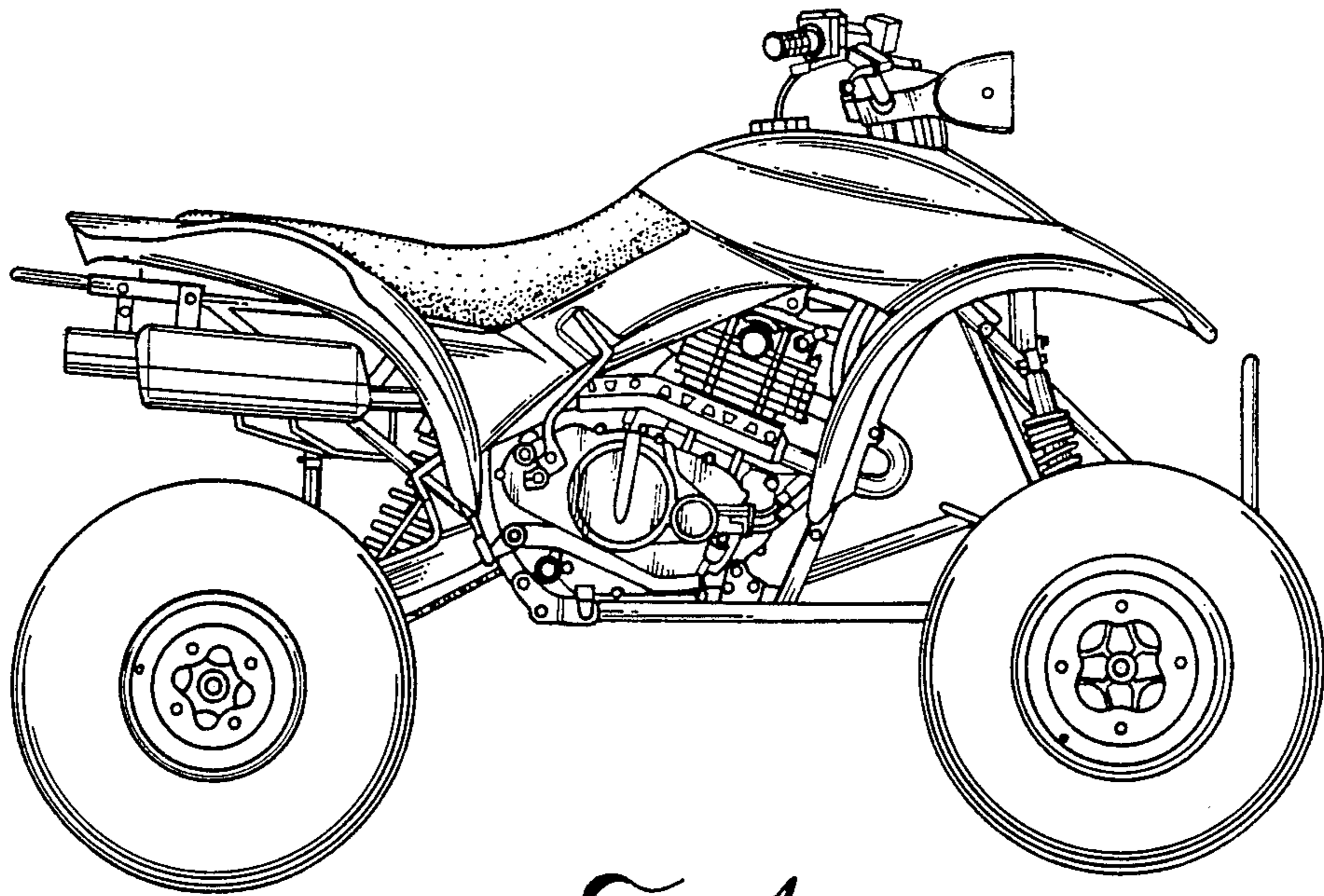
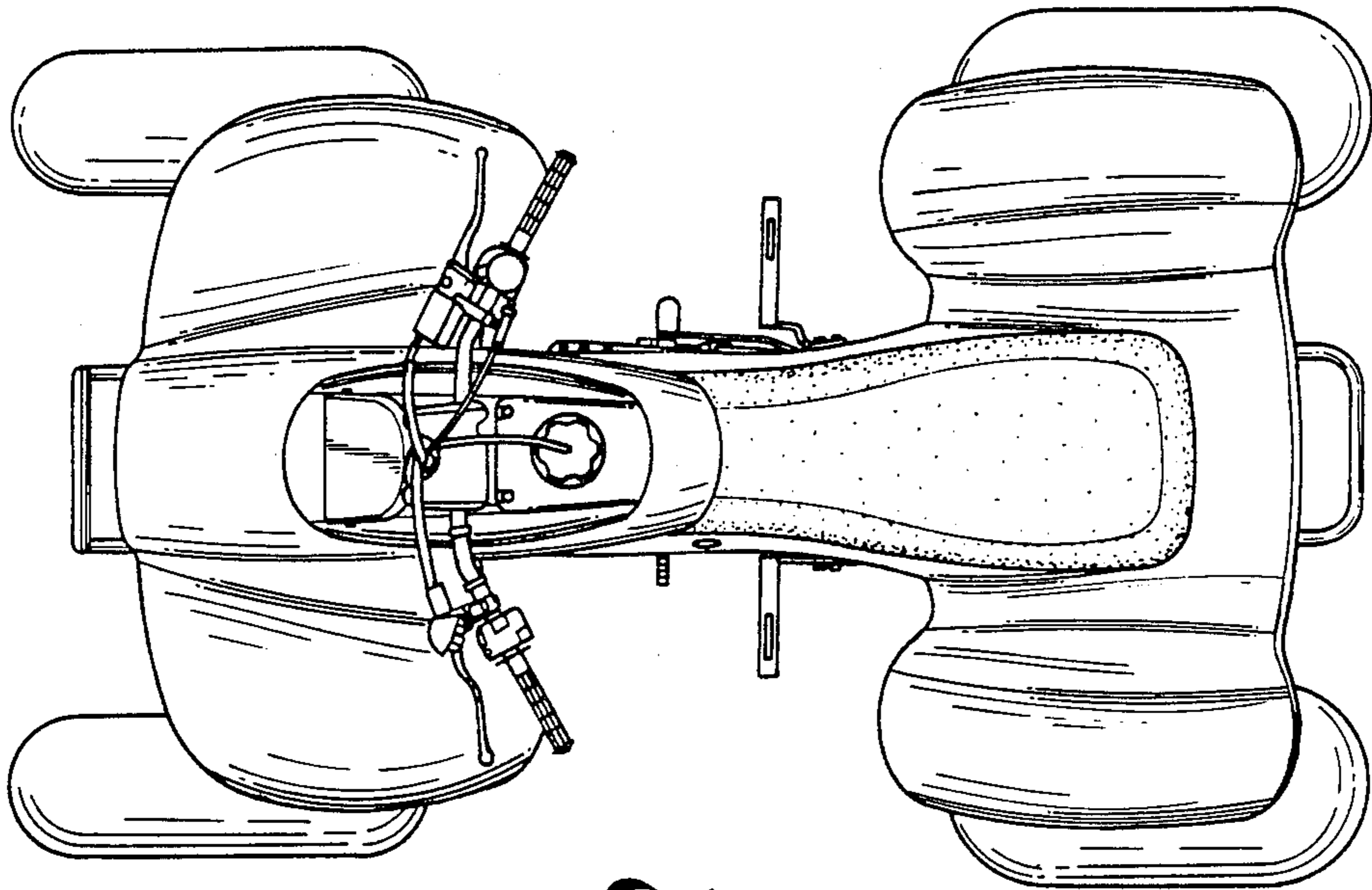
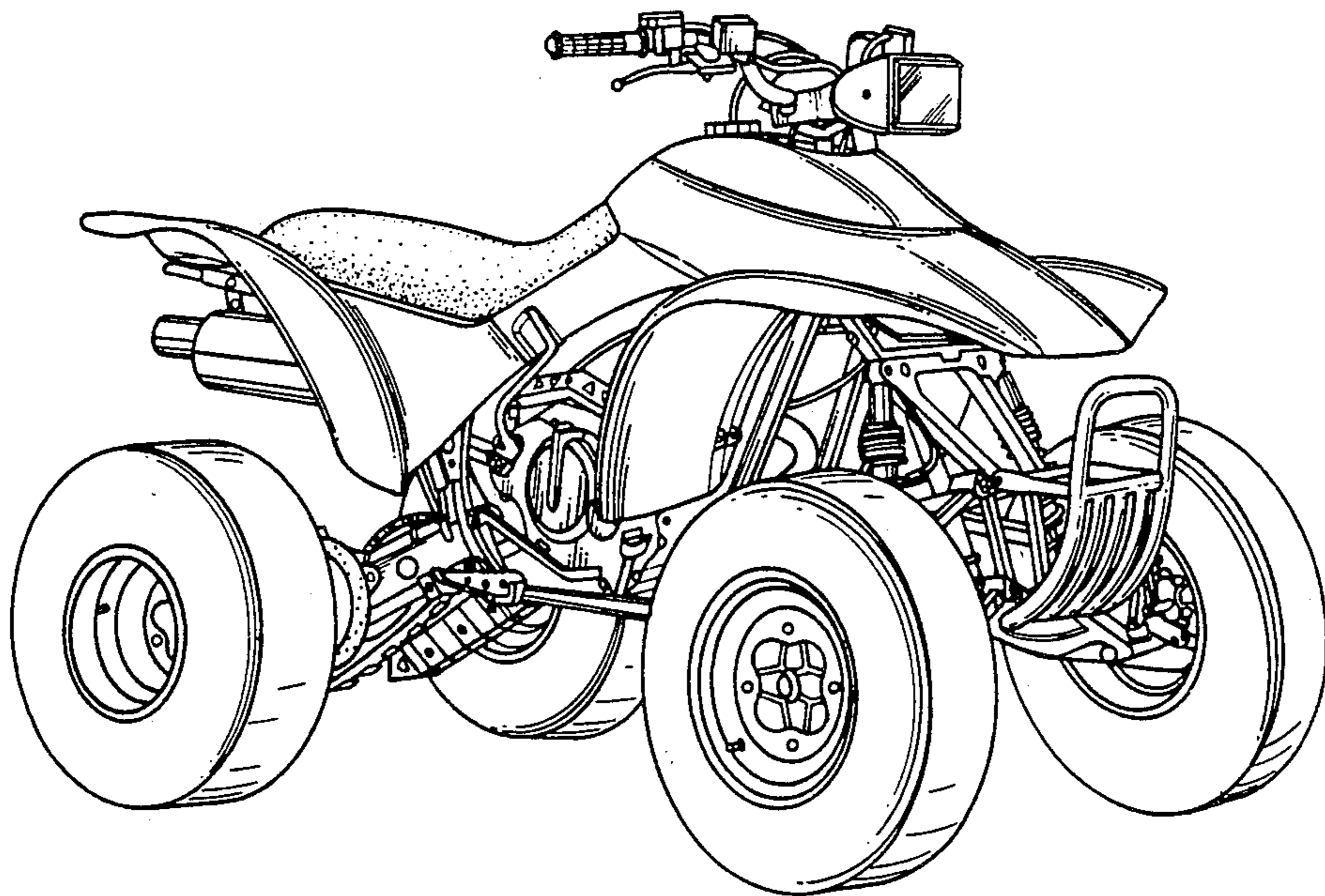

FIG. 4.



*FIG. 5.*



*FIG. 6.*