

[54] LUGGAGE CART

[76] Inventor: Gilbert J. Holtz, 182 Tibbetts Rd., Yonkers, N.Y. 10705

[\*\*] Term: 14 Years

[21] Appl. No.: 699,161

[22] Filed: Feb. 7, 1985

[52] U.S. Cl. .... D34/26

[58] Field of Search ..... D34/12, 24, 26; 280/47.24, 47.26, 653, 654, 655

[56] References Cited

U.S. PATENT DOCUMENTS

3,998,476	12/1976	Kazmark, Sr. ....	D34/26
4,040,642	8/1977	David .....	280/654
4,248,453	2/1981	Stark .....	280/655
4,458,914	7/1984	Holtz .....	280/655
4,523,773	6/1985	Holtz .....	280/655
4,630,837	12/1986	Kazmark .....	280/655

FOREIGN PATENT DOCUMENTS

1509040 11/1966 France ..... 280/655

Primary Examiner—Wallace R. Burke  
Assistant Examiner—Kay H. Chin  
Attorney, Agent, or Firm—Myron Amer

[57] CLAIM

The ornamental design for a luggage cart, as shown and described.

DESCRIPTION

FIG. 1 is a small scale isometric view of a luggage cart showing my new design;  
FIG. 2 is a front elevational view thereof;  
FIG. 3 is a right side elevational view thereof, the left side being a mirror image thereof;  
FIG. 4 is a top plan view thereof;  
FIG. 5 is a rear elevational view thereof; and  
FIG. 6 is a bottom plan view thereof.  
The elastic bands shown in FIGS. 1, 3, 4 and 6 have been shown broken away for convenience of illustration.

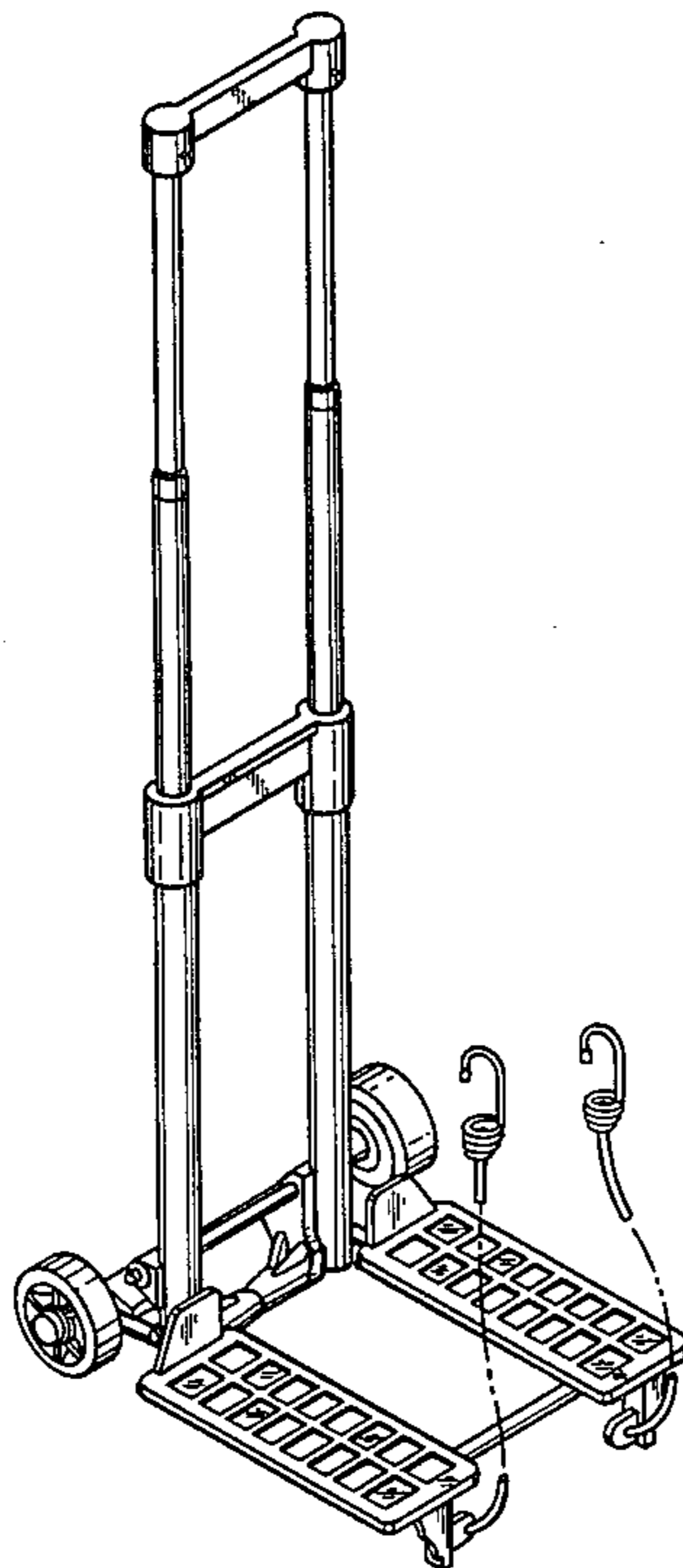

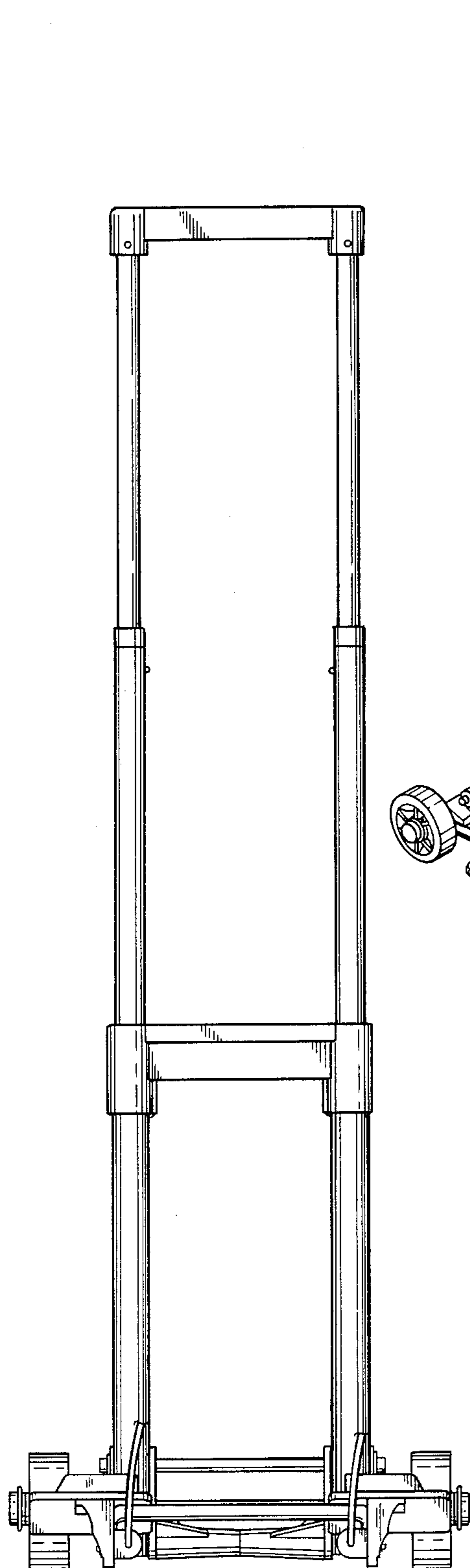

FIG. 2

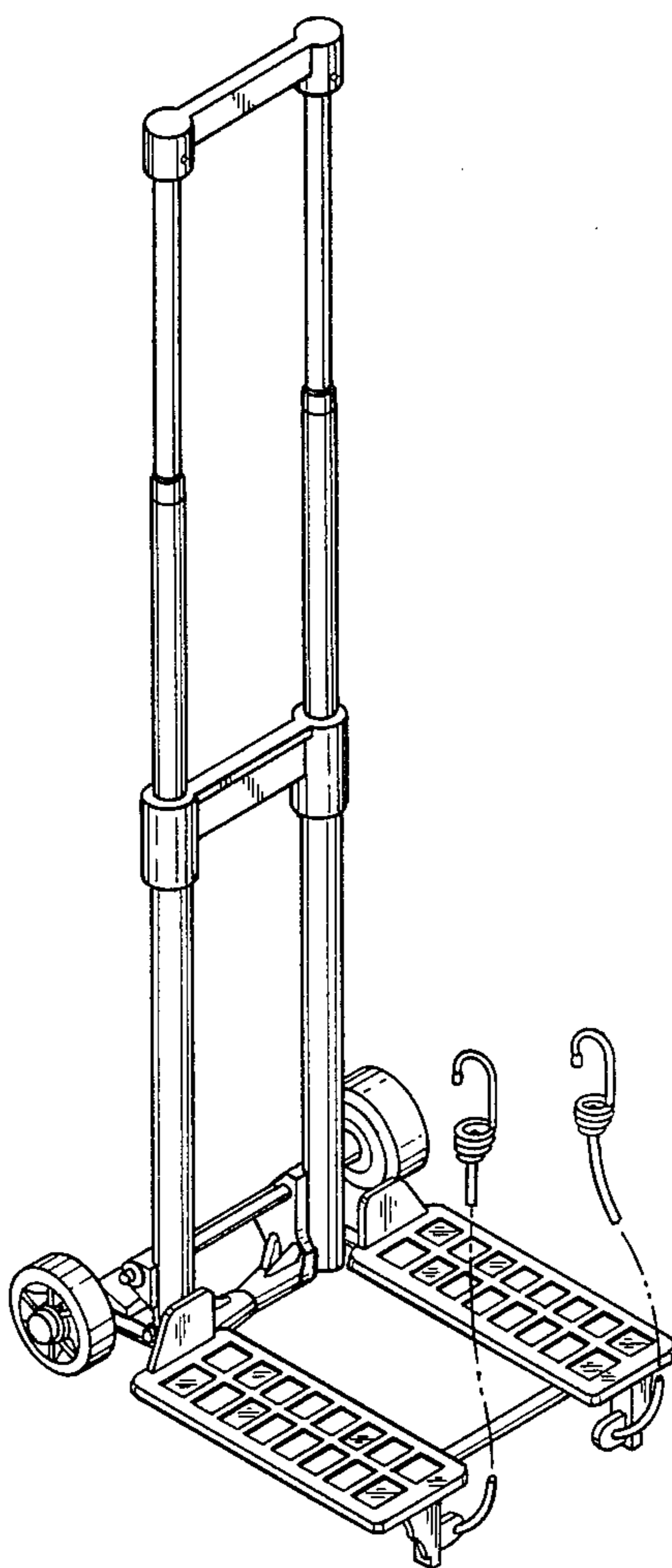

FIG. 1

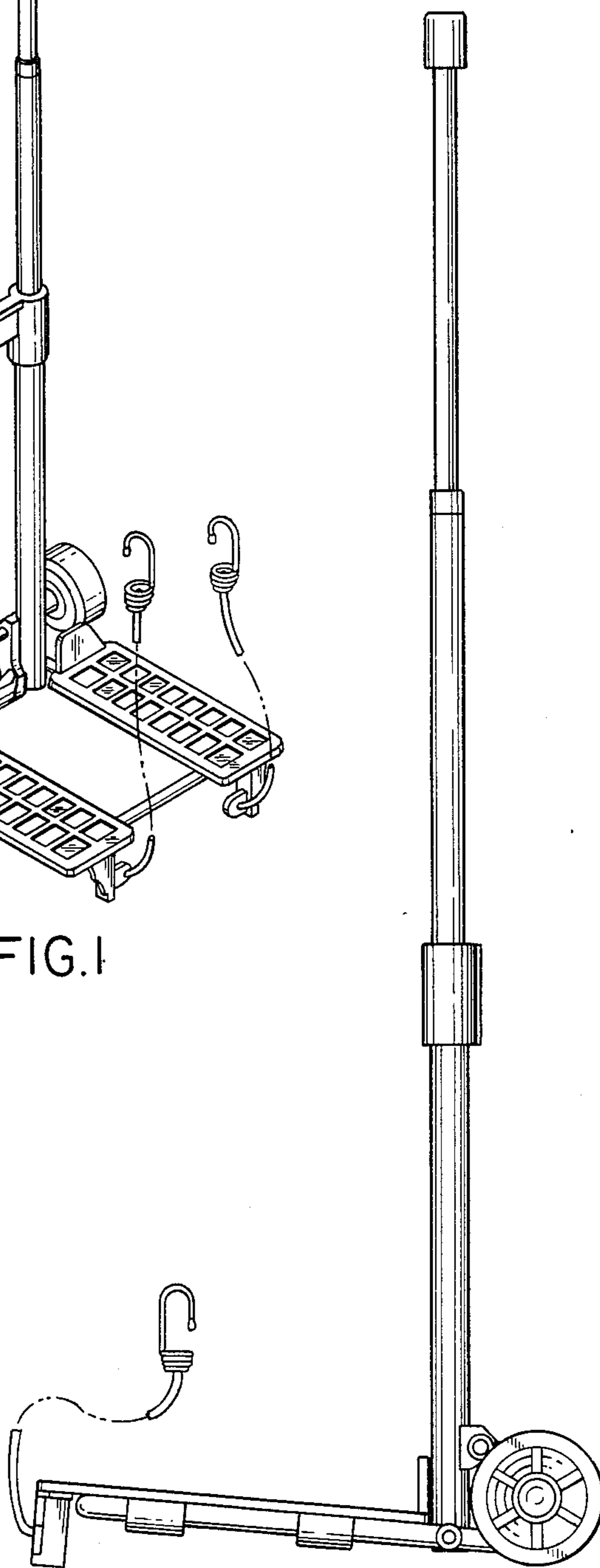

FIG. 3

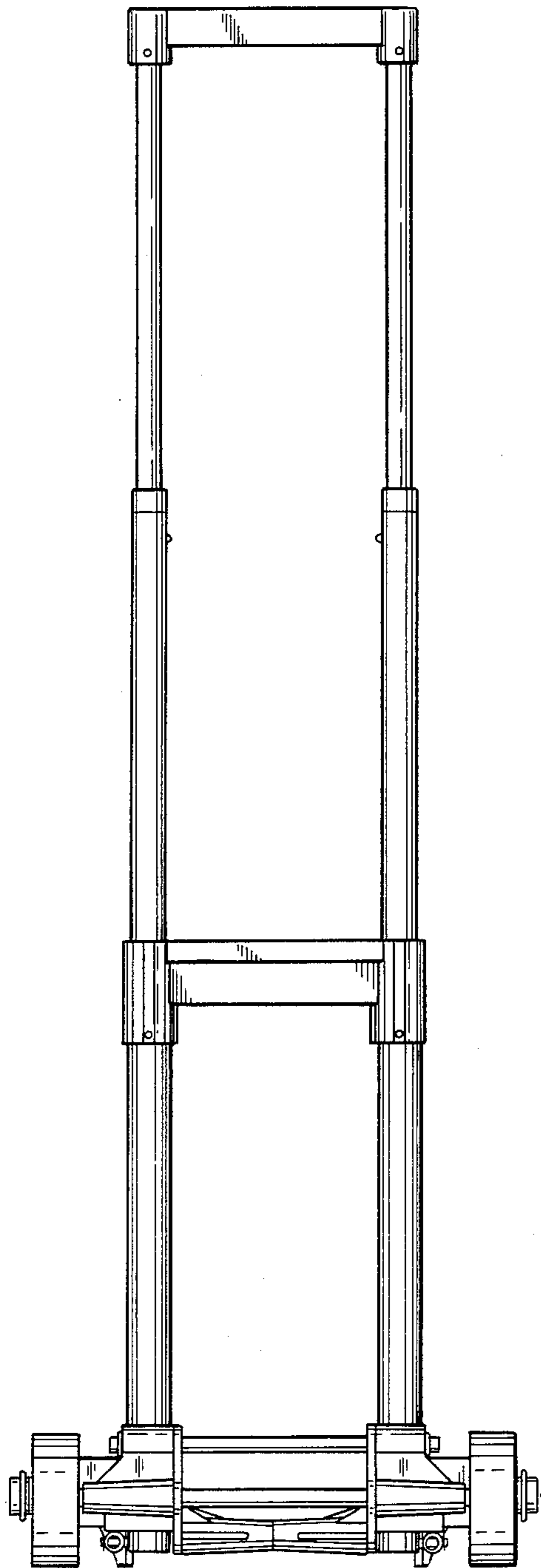

FIG. 5

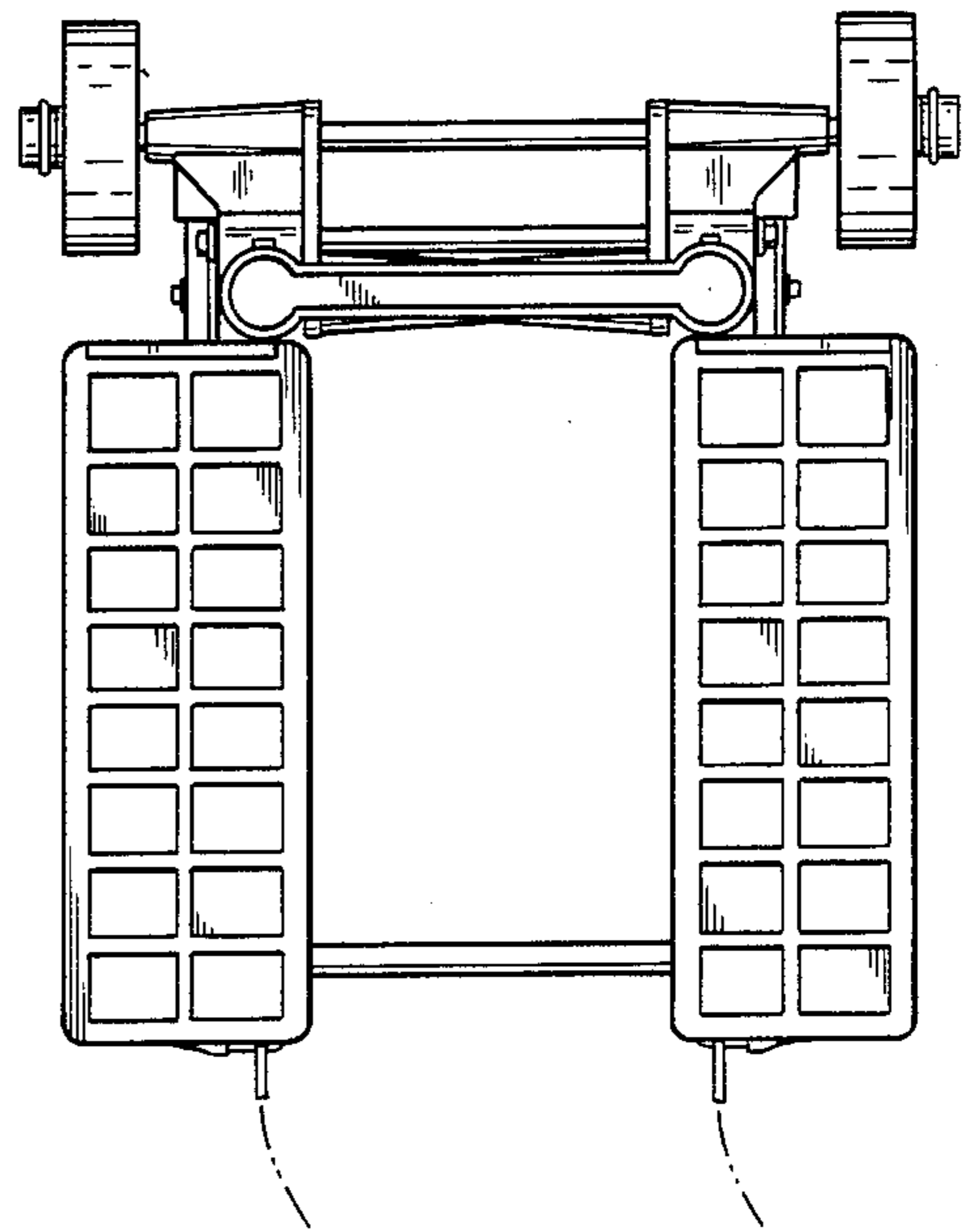

FIG. 4

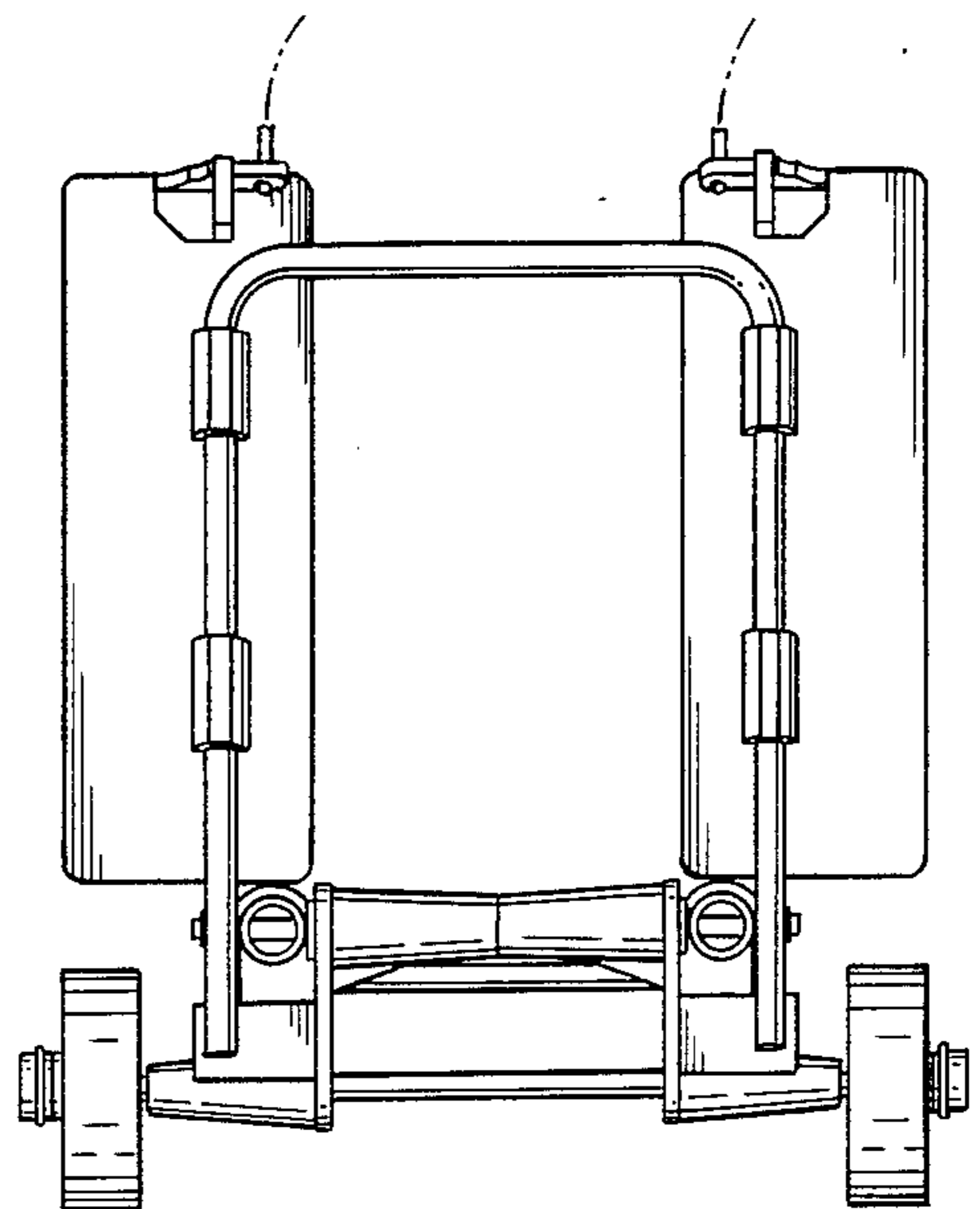

FIG. 6