

[54] AIR FILTER HOUSING FOR MOUNTING ON AN INTERNAL COMBUSTION ENGINE

[75] Inventors: Charles L. Matheson, Cookeville, Tenn.; Emilio Ambasz, New York, N.Y.

[73] Assignee: Cummins Engine Company, Inc., Columbus, Ind.

[**] Term: 14 Years

[21] Appl. No.: 836,462

[22] Filed: Feb. 21, 1986

[52] U.S. Cl. D23/365; D15/5

[58] Field of Search D23/146-151; 55/276, 385 F, 413, 418, 434, 440, DIG. 18, DIG. 36, 510; 98/61, 115.1; 123/22, 26, 1 R, 41.56; D15/1-9

[56] References Cited

U.S. PATENT DOCUMENTS

D. 205,741 9/1966 White D23/147

OTHER PUBLICATIONS

Grainger's Spring 1974 Catalogue, p. 529-Shaded Pole Blower, No. 4C264.

Primary Examiner—Wallace R. Burke

Assistant Examiner—Brian N. Vinson

[57] CLAIM

The ornamental design of an air filter housing for mounting on an internal combustion engine, substantially as shown and described.

DESCRIPTION

FIG. 1 is a right side elevational view of an air filter housing for mounting on an internal combustion engine showing our new design;

FIG. 2 is an enlarged, fragmentary, vertical cross-sectional view thereof, taken along line 2-2 of FIG. 1;

FIG. 3 is a rear perspective view thereof; and

FIG. 4 is an enlarged front and right side perspective view thereof, the undisclosed bottom being plain and unornamented.

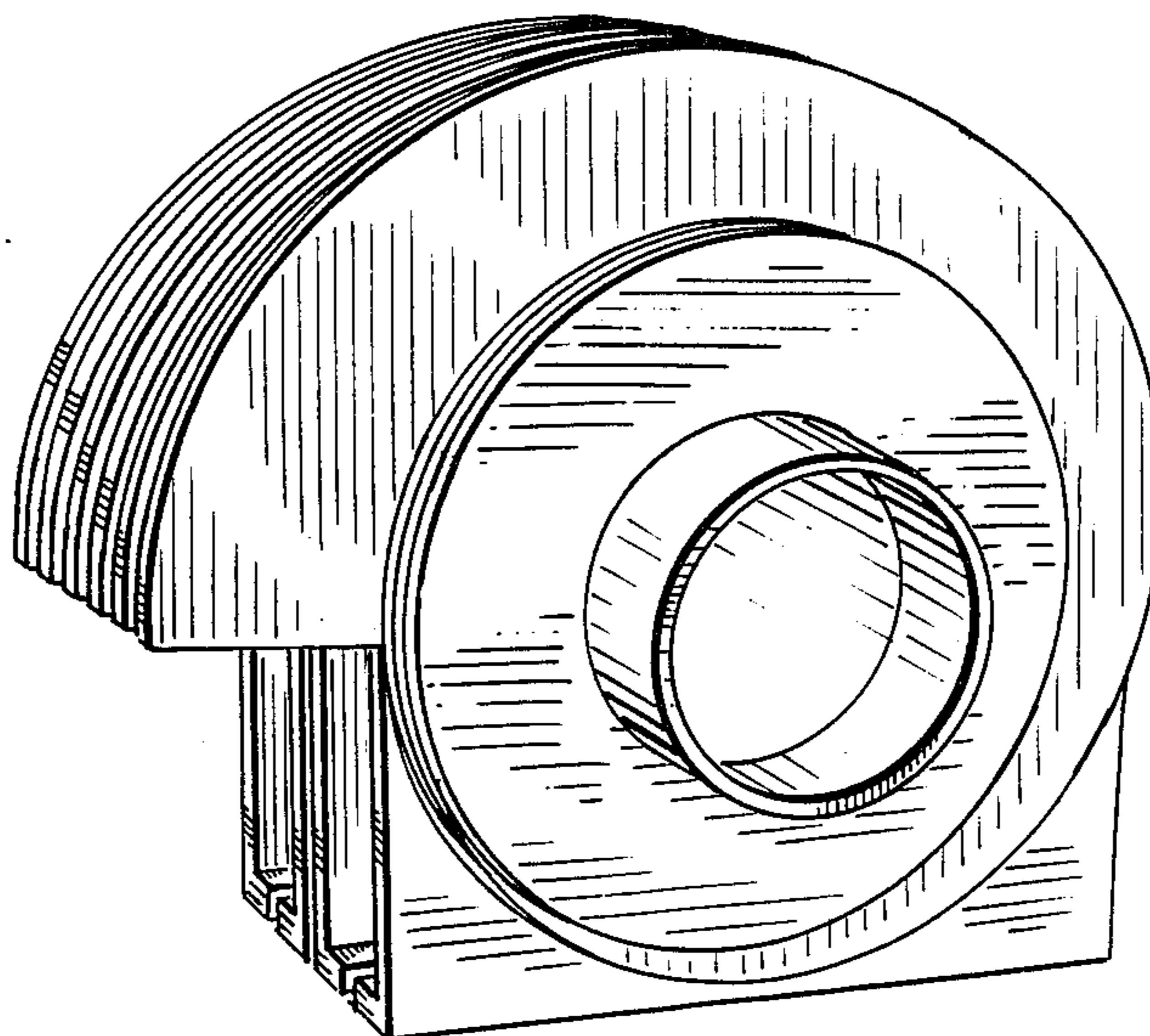

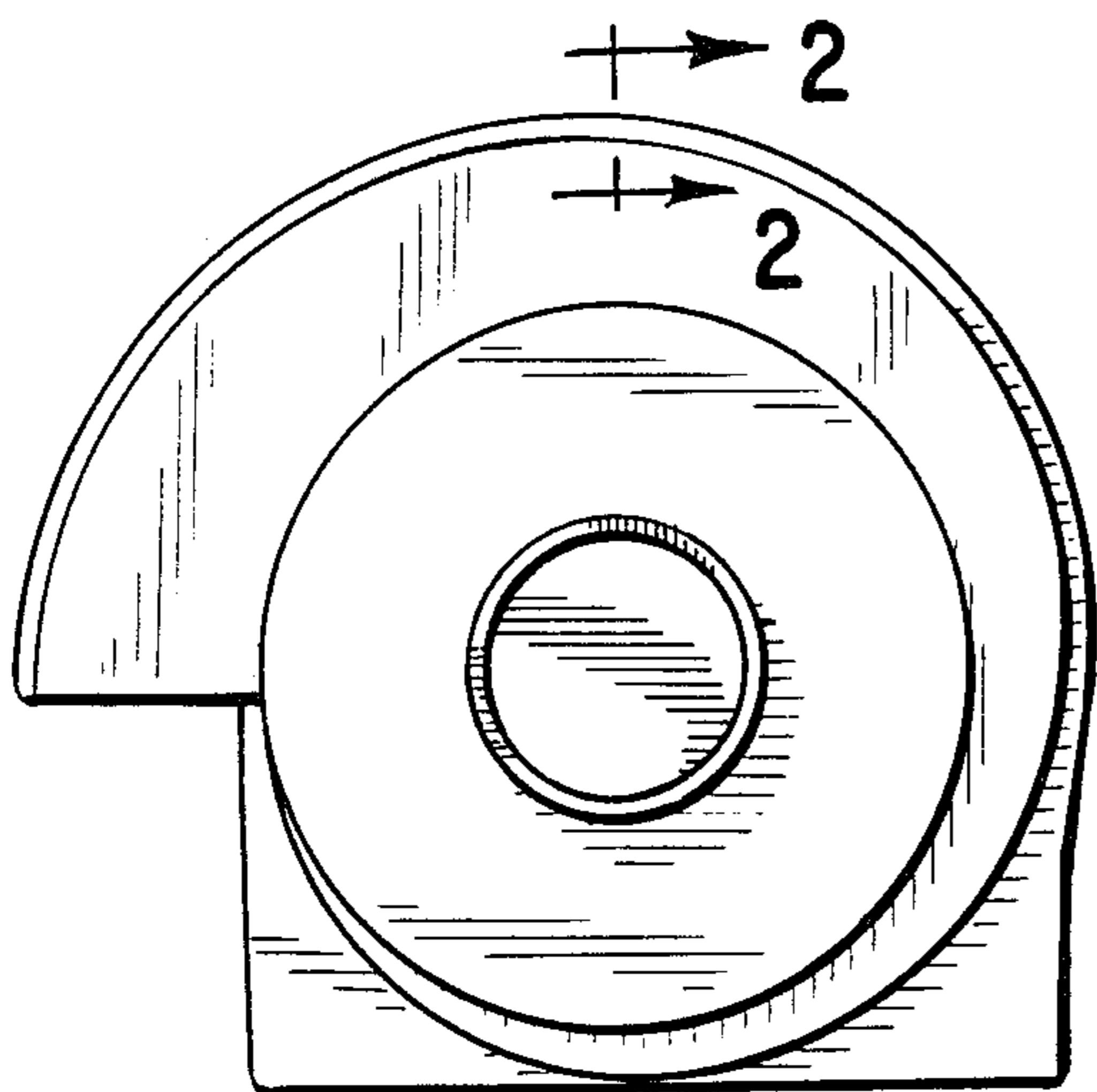

FIG. 1



FIG. 2

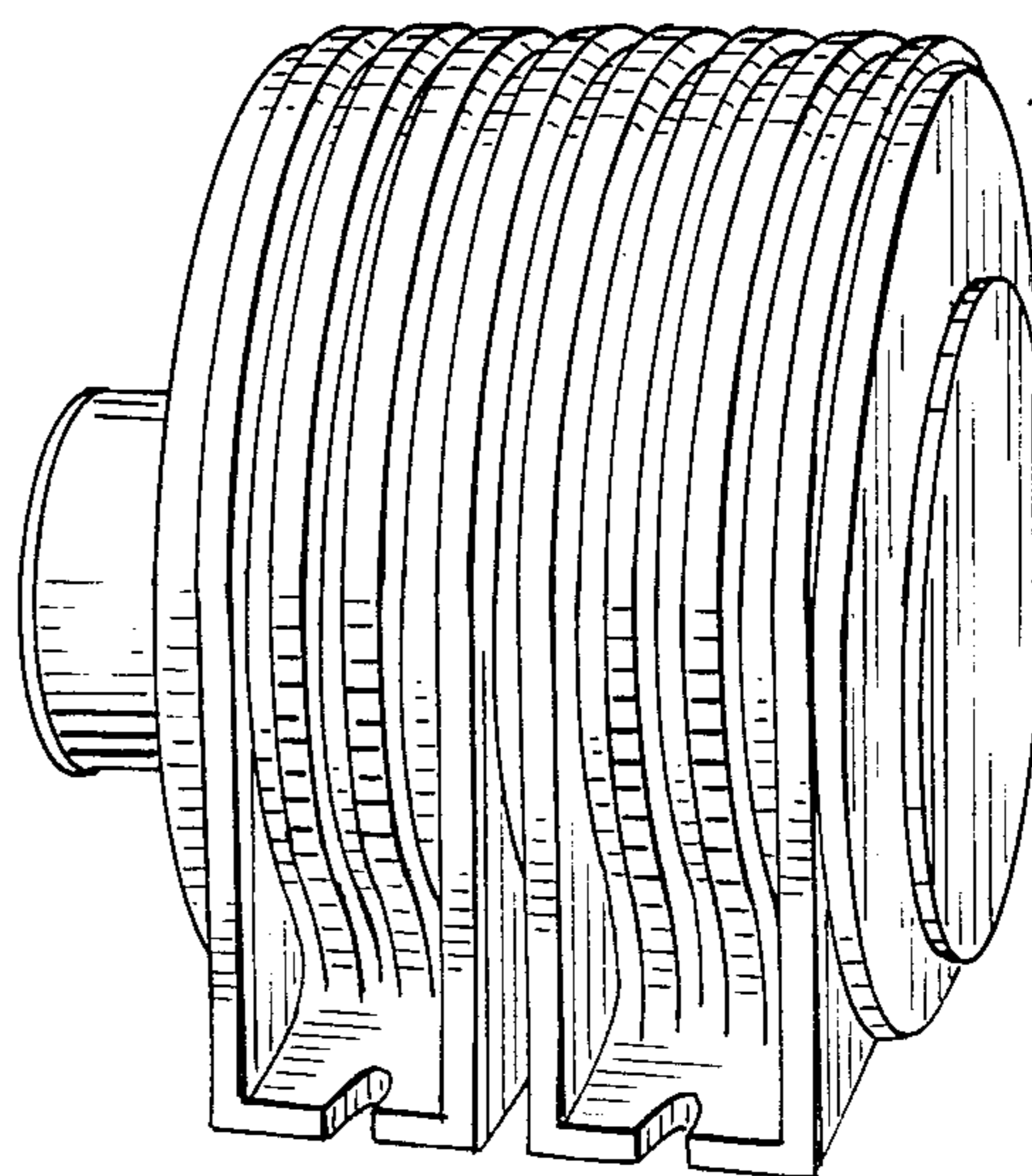

FIG. 3

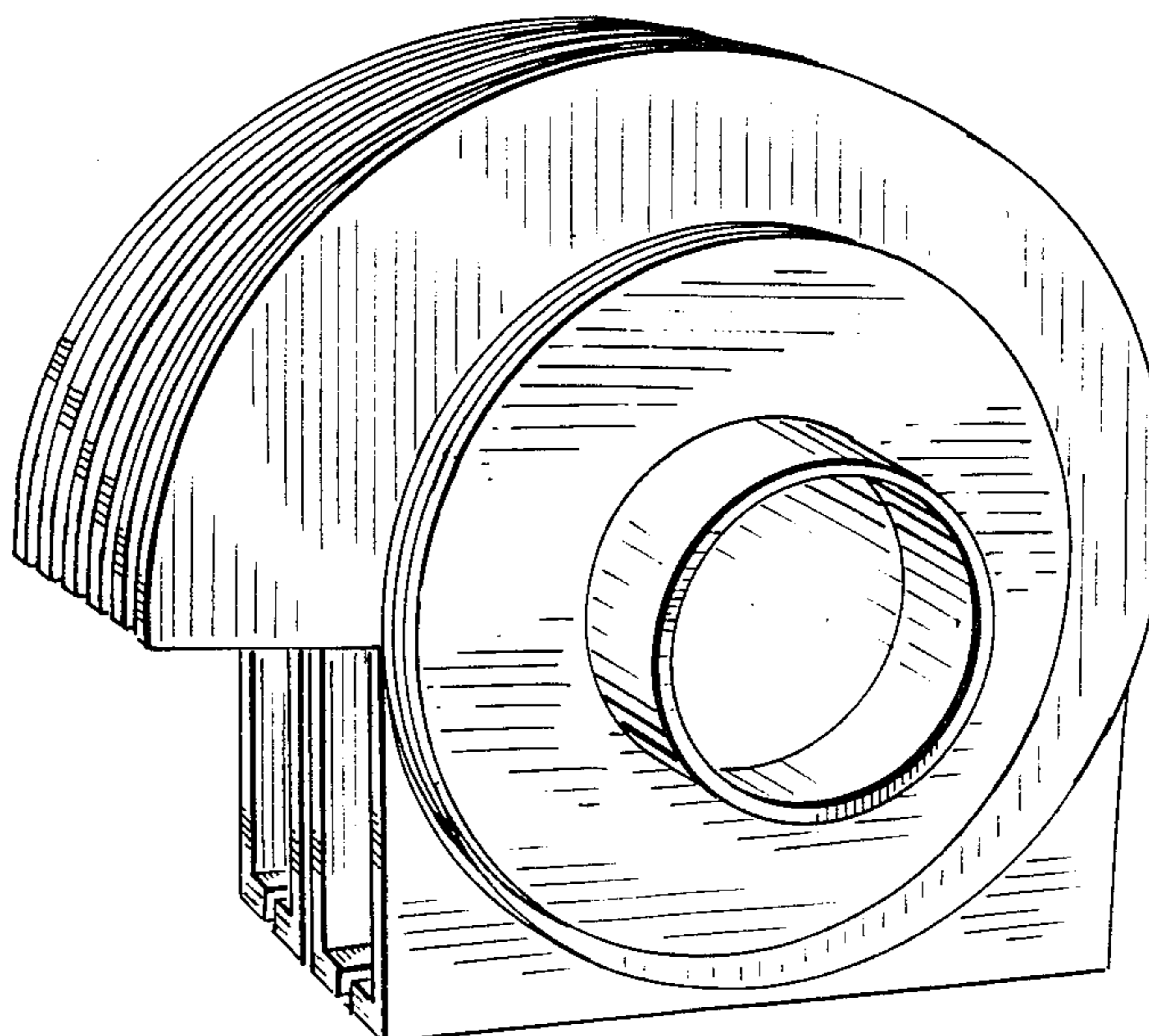

FIG. 4