

[54] COMBINATION CAR SEAT AND STROLLER

[76] Inventor: Willard F. McMillen, 2711 Bentwood St., Palestine, Tex. 75801

[\*\*] Term: 14 Years

[21] Appl. No.: 771,114

[22] Filed: Aug. 30, 1985

[52] U.S. Cl. .... D12/129; D6/333

[58] Field of Search ..... D12/129, 130; 297/487, 297/464, 130, 250, 253-256; 280/30, 47.37 R; D6/333; 296/1 B

[56] References Cited

U.S. PATENT DOCUMENTS

D. 165,383	11/1951	Lorenzana .....	D12/129
D. 198,206	5/1964	Conti .....	D12/129
2,990,190	6/1961	Eriksen .....	280/30
3,829,113	8/1974	Epelbaum .....	D12/129
3,944,241	3/1976	Epelbaum .....	280/43.24
4,376,551	3/1983	Cone .....	297/250

4,537,414	8/1985	Nusbaum .....	280/47.37 R
4,634,185	1/1987	Kassai .....	297/250

Primary Examiner—Wallace R. Burke  
Assistant Examiner—Kay H. Chin  
Attorney, Agent, or Firm—W. C. Tupman

[57] CLAIM

The ornamental design for a combination car seat and stroller, as shown and described.

DESCRIPTION

FIG. 1 is a rear elevational view of a combination car seat and stroller showing my new design; FIG. 2 is a front elevational view thereof; FIG. 3 is a left side elevational view thereof, with the handle in lowered condition; FIG. 4 is an enlarged perspective view of a detached seat member of the combination car seat and stroller; FIG. 5 is an enlarged perspective view of a detached carriage member of the combination car seat and stroller.

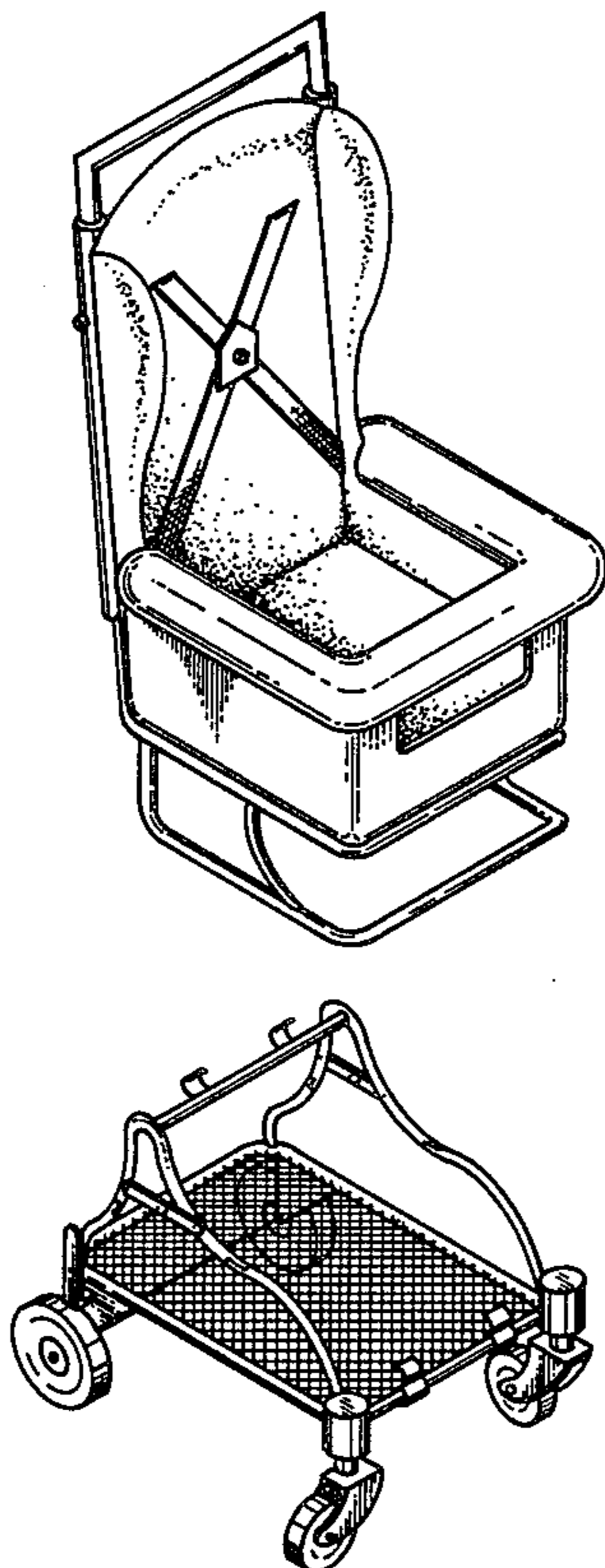

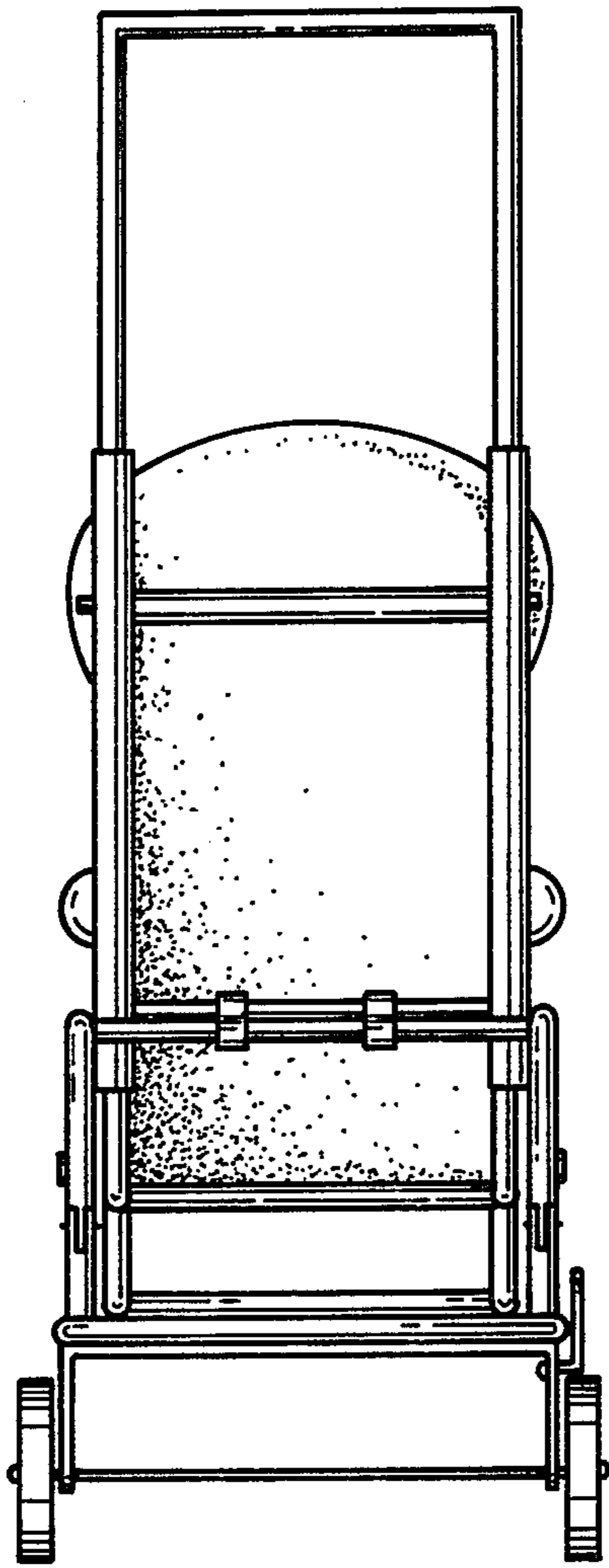

Fig. 1

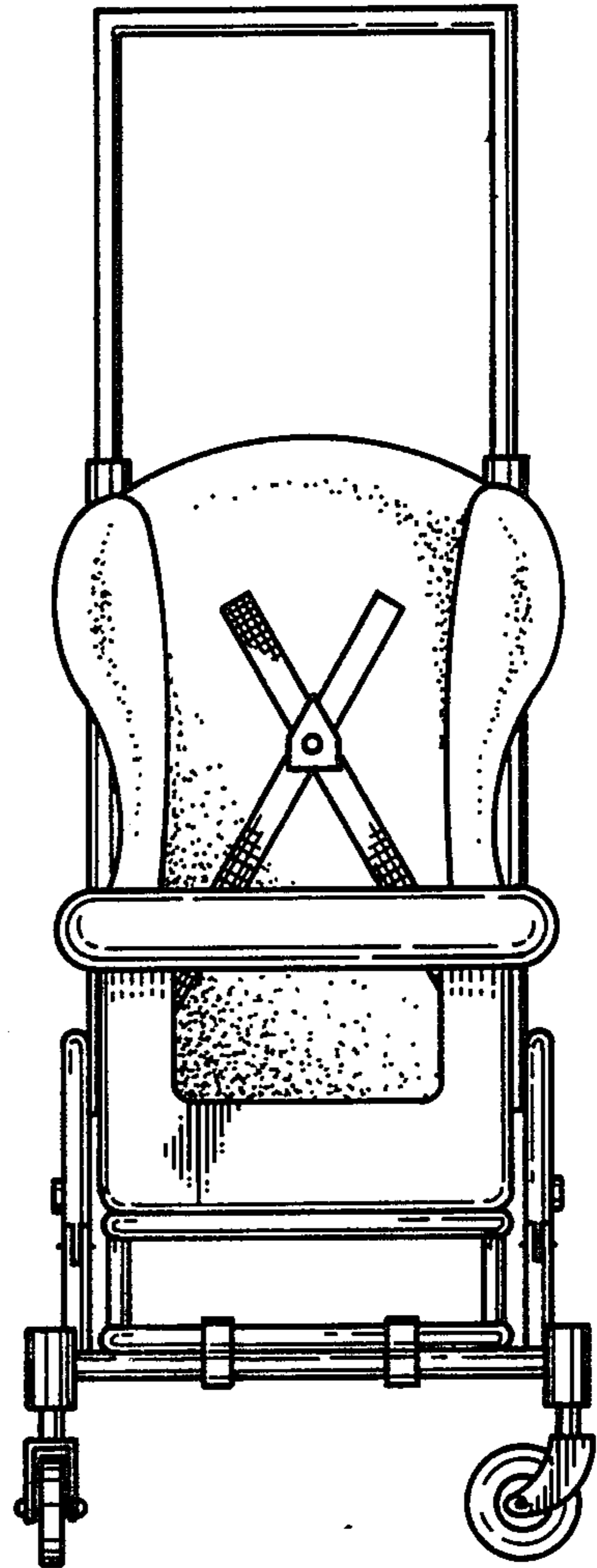
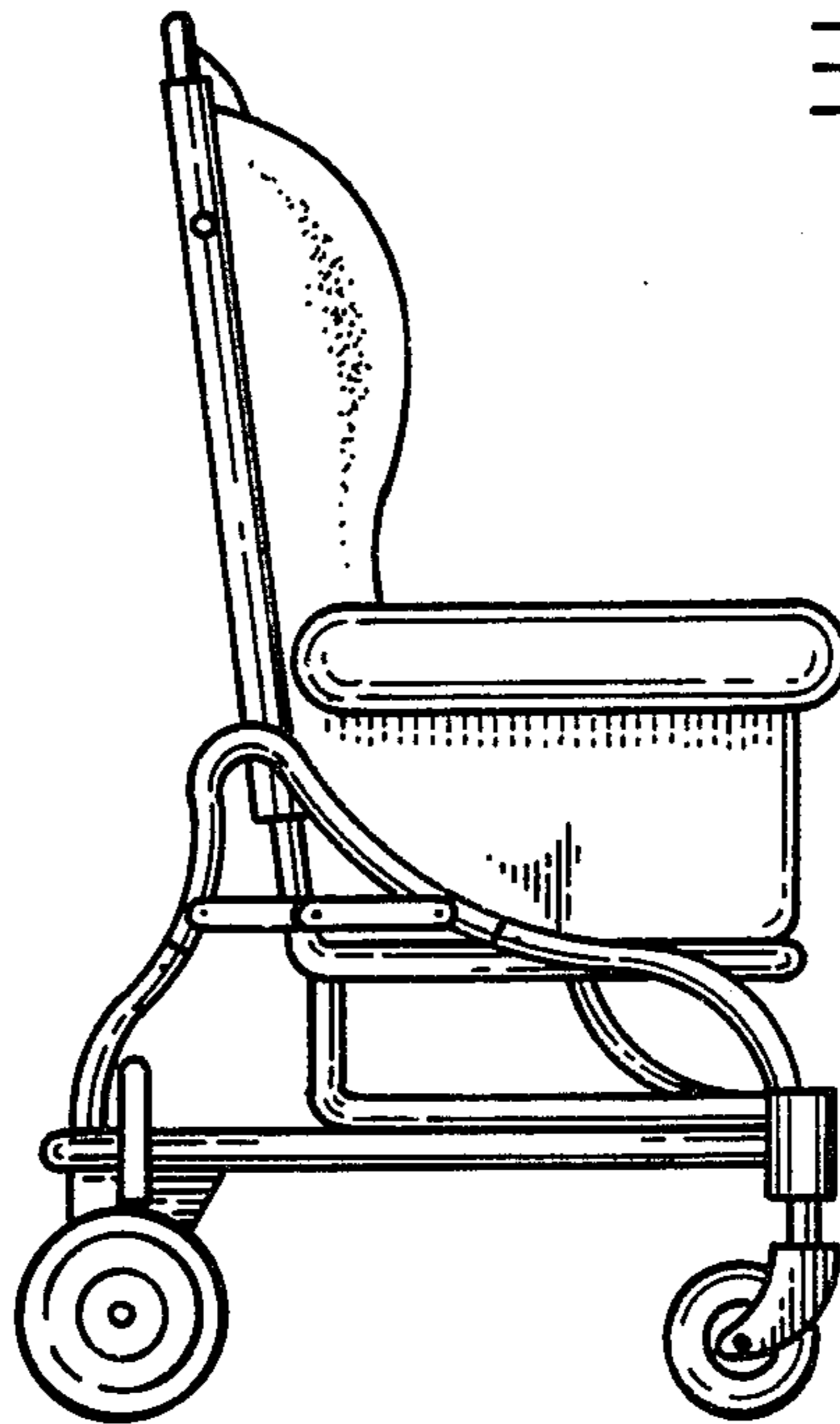

Fig. 2

Fig. 3



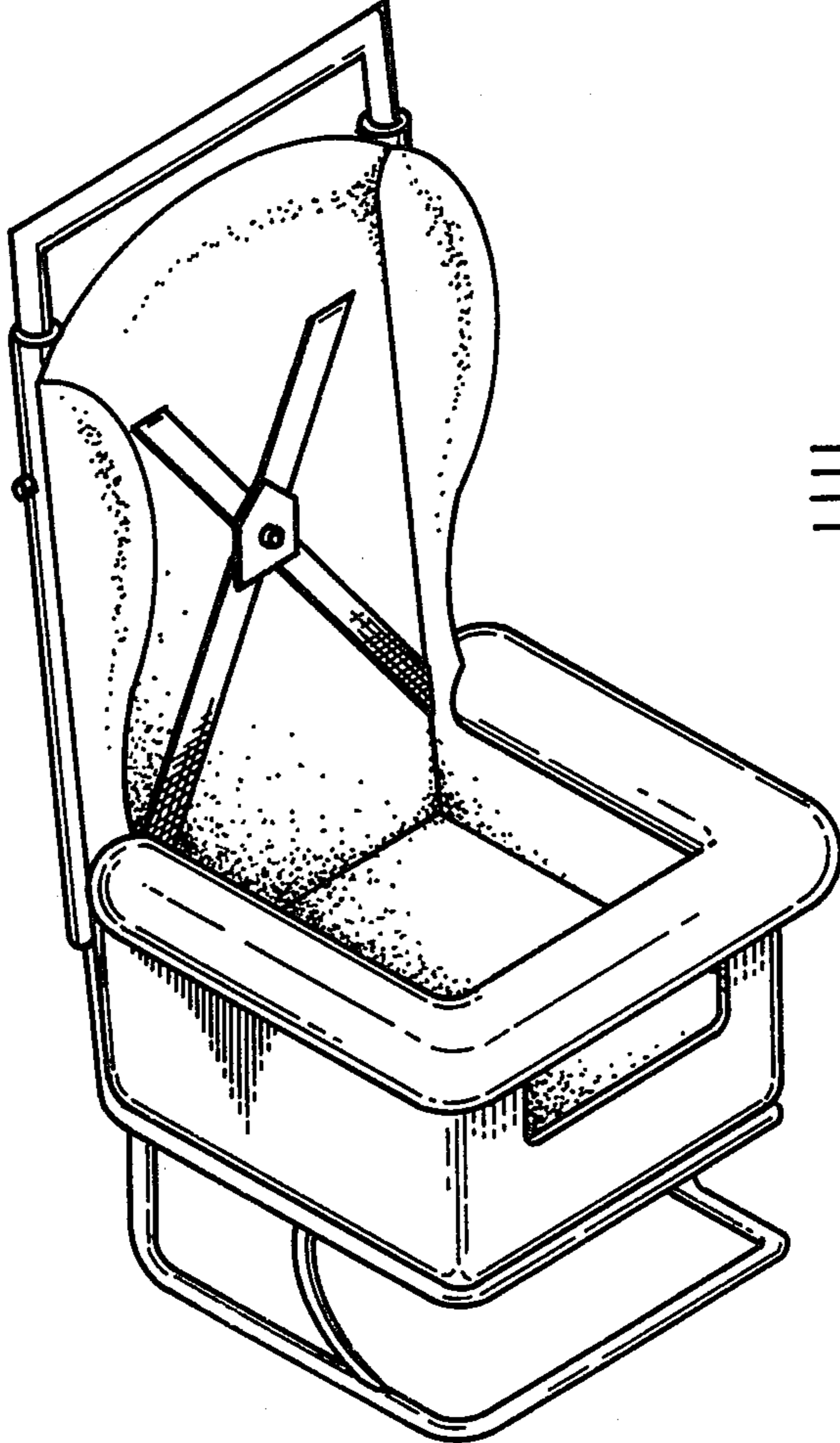

Fig. 4

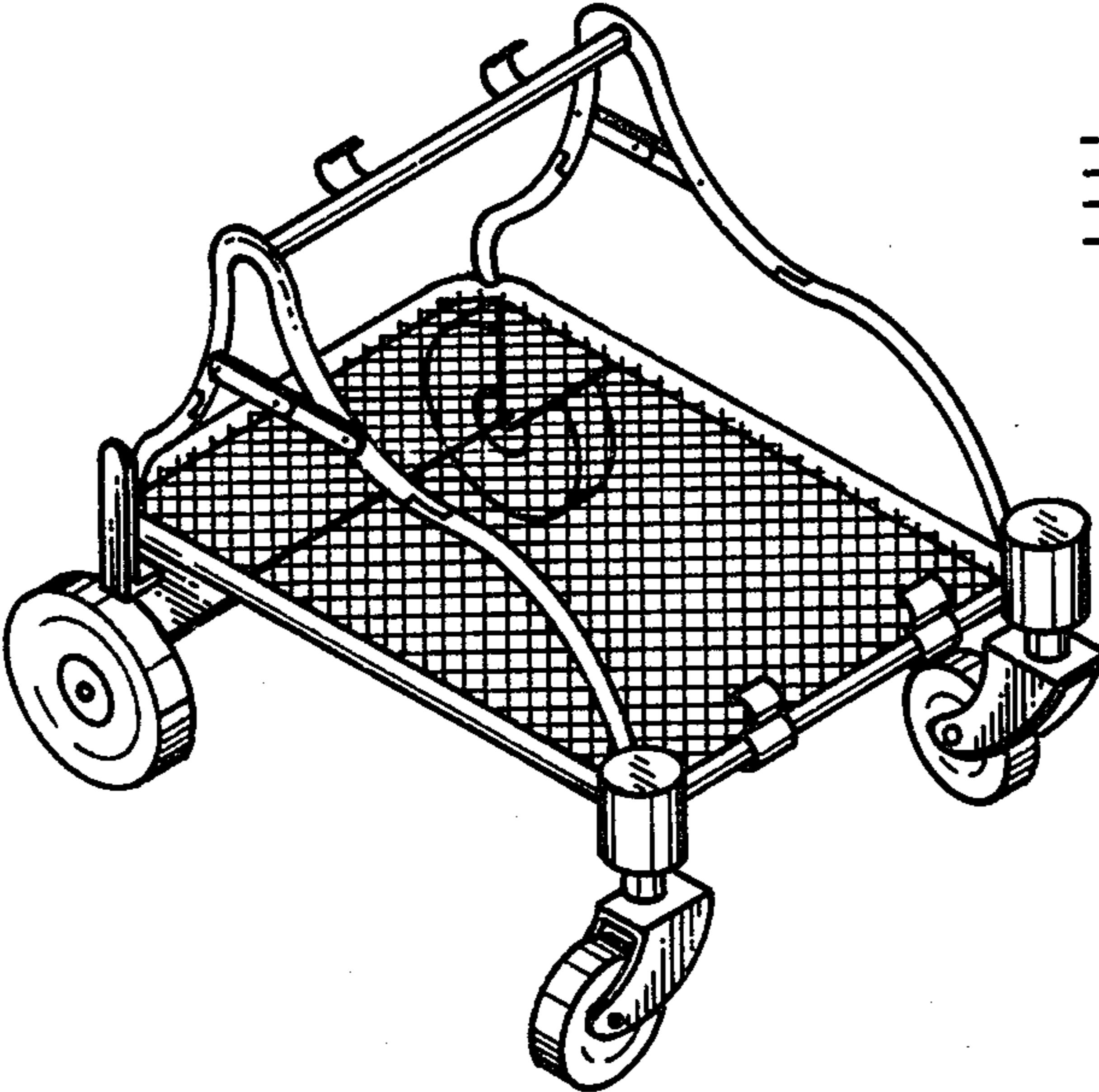

Fig. 5