

[54] COMBINED CORDLESS SCREWDRIVER AND CHARGING STAND

4,397,055 8/1983 Cuchiara ..... 320/2 X  
4,653,359 3/1987 Lias ..... 81/475

[75] Inventor: Kenneth N. Svetlik, Schaumburg, Ill.

[73] Assignee: Skil Corporation, Chicago, Ill.

[\*\*] Term: 14 Years

[21] Appl. No.: 808,272

[22] Filed: Dec. 12, 1985

[52] U.S. Cl. .... D8/61; D8/70

[58] Field of Search ..... D8/61, 68, 75, 82, 83,  
D8/105; 408/120, 124-125, 127; 310/50;  
320/2-4; 173/163, 170; 81/44, 52, 53.12, 54,  
57.11, 463-464, 466-467, 478, 480, 177.1, 177.7,  
438

[56] References Cited

U.S. PATENT DOCUMENTS

- D. 215,998 11/1969 Humphrey et al. .... D8/61
- D. 217,218 4/1970 Staub ..... D8/61
- 1,603,985 10/1926 Rosenberg ..... 81/436 X
- 2,491,325 12/1949 McVey ..... 81/474 X
- 3,329,880 7/1967 Boyles ..... 310/50
- 3,873,868 3/1975 Pew ..... 310/50
- 3,890,859 6/1975 Grabovac et al. .... 81/474
- 4,030,383 6/1977 Wagner ..... 81/54
- 4,078,589 3/1978 Miller ..... 310/50 X
- 4,170,909 10/1979 Wagner ..... 81/177.7 X
- 4,225,814 9/1980 Gantz et al. .... 320/2
- 4,374,354 2/1983 Petrouic et al. .... 320/2

OTHER PUBLICATIONS

Disston brochure, 1976, "Cordless Electric Power Screwdriver".

Amercep Inc. brochure, 1983, "Turbo Driver Rechargeable Screwdriver".

Daikyo brochure, undated, "Cordless Driver", No. SA-701.

Milwaukee Elec. Corp. brochure, "Cordless Heavy-Duty Reversing Screwdriver, No. 6539-1, undated.

Primary Examiner—Wallace R. Burke

Assistant Examiner—Brian N. Vinson

Attorney, Agent, or Firm—Jones, Day, Reavis & Pogue

[57] CLAIM

The ornamental design for a combined cordless screwdriver and charging stand, as shown and described.

DESCRIPTION

FIG. 1 is a top perspective view of a combined cordless screwdriver and charging stand showing my new design;

FIG. 2 is a top plan view thereof;

FIG. 3 is a right side elevational view thereof, the left side being a mirror image;

FIG. 4 is a bottom plan view thereof;

FIG. 5 is a front end elevational view thereof; and

FIG. 6 is a rear end elevational view thereof.

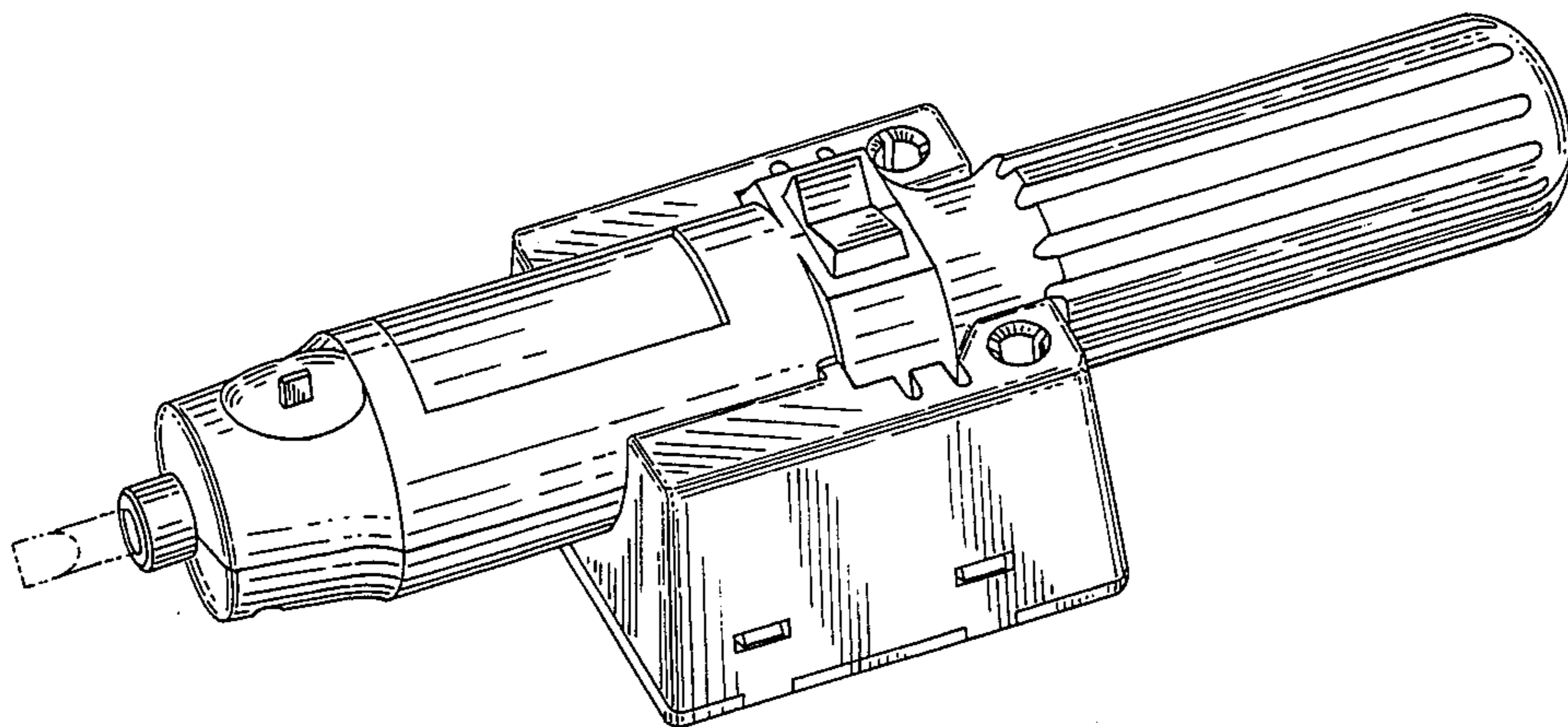

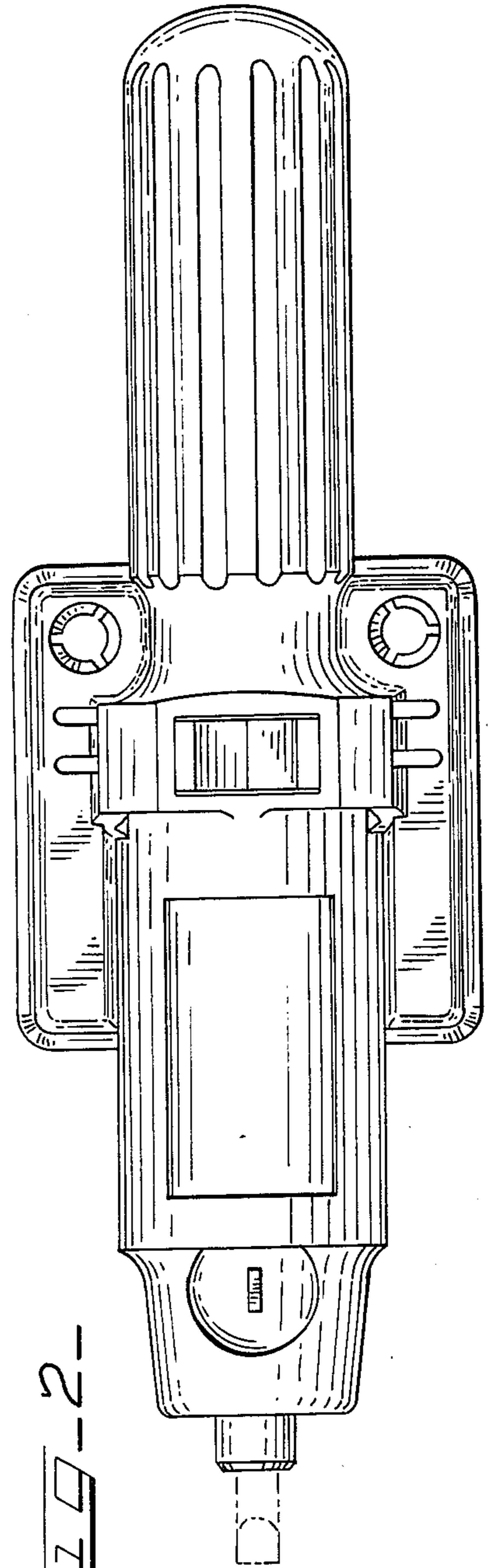
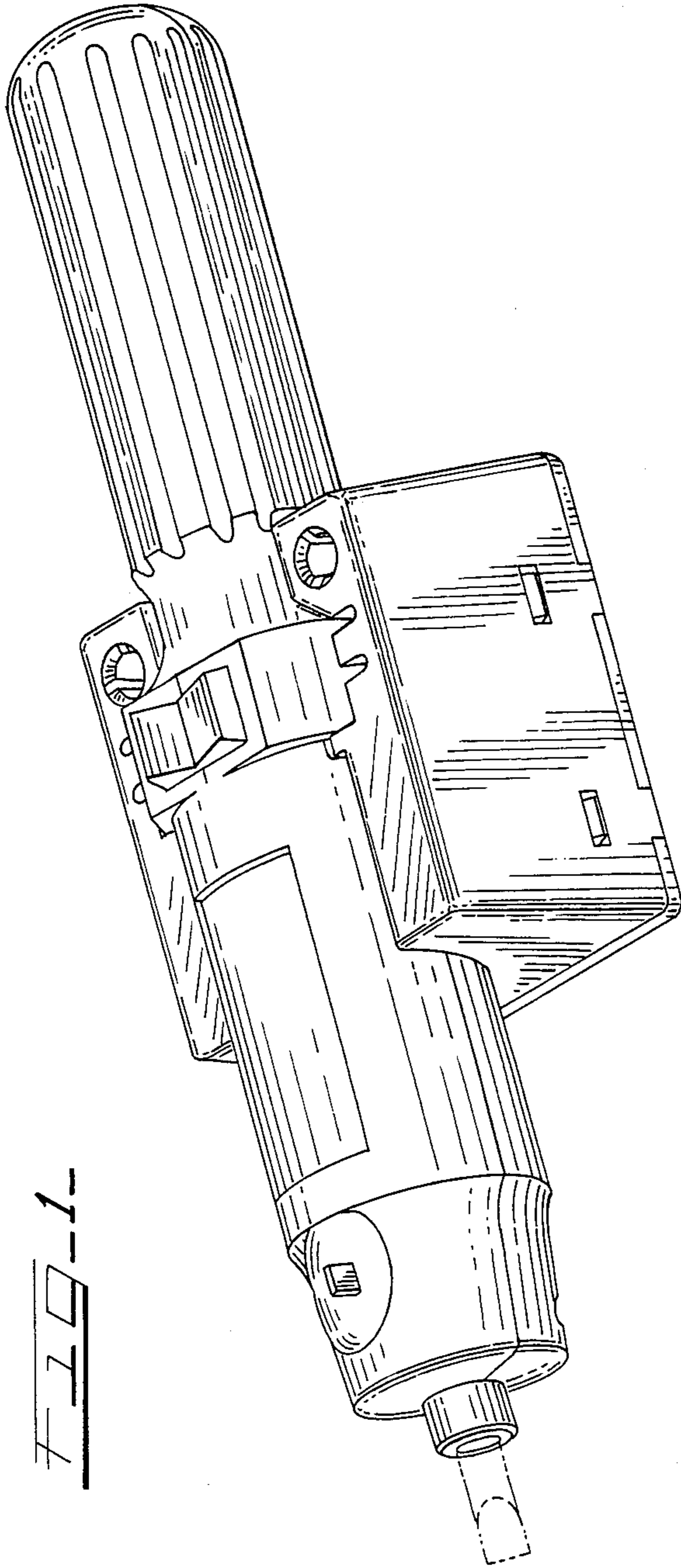

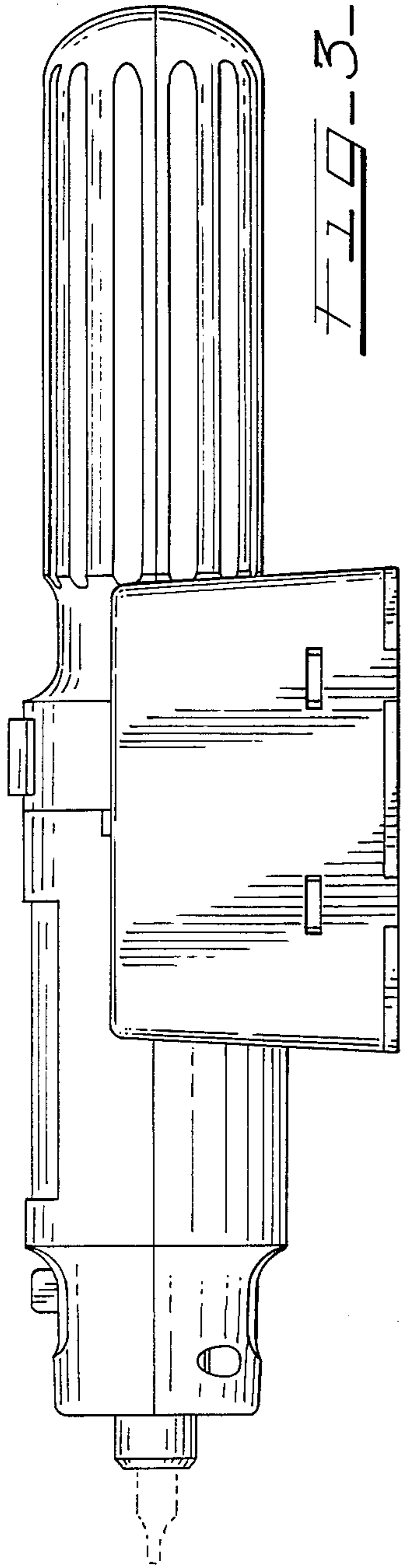

FIG. 3-

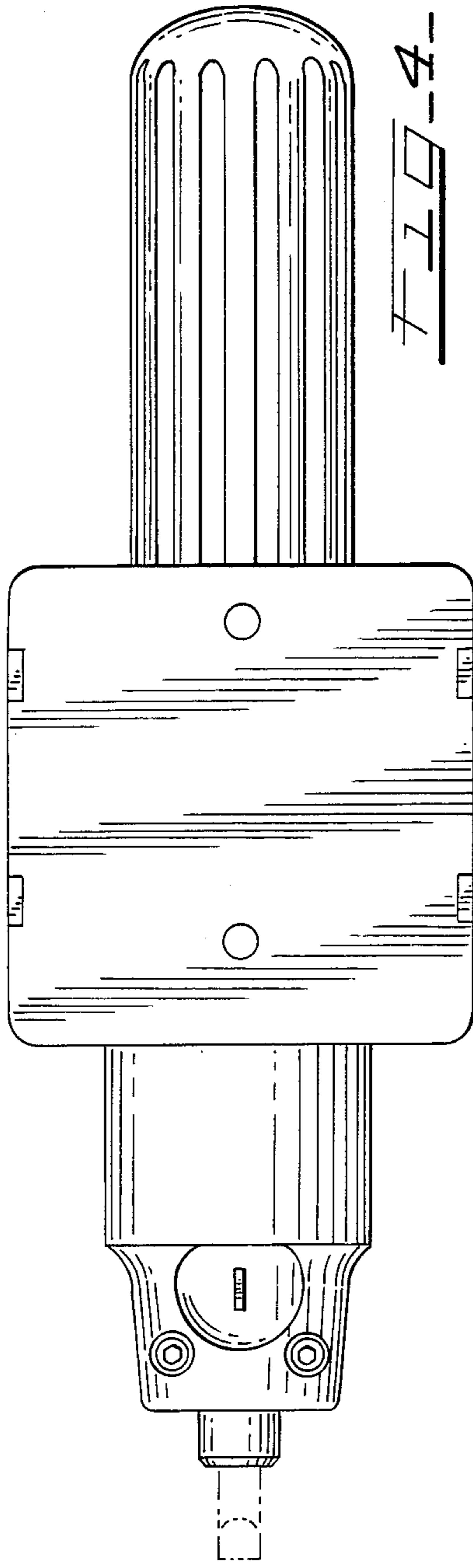

FIG. 4-

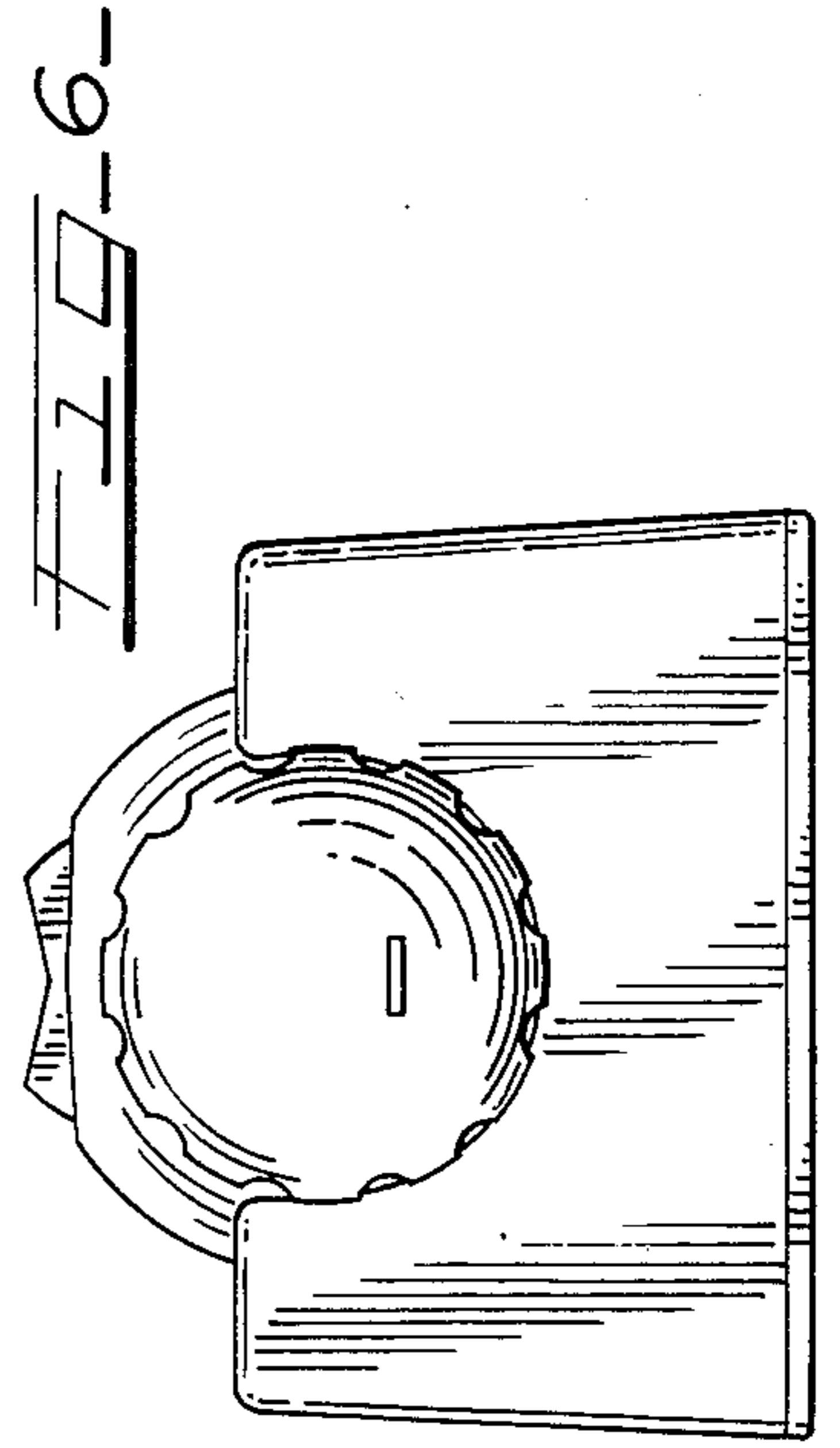

FIG. 6-

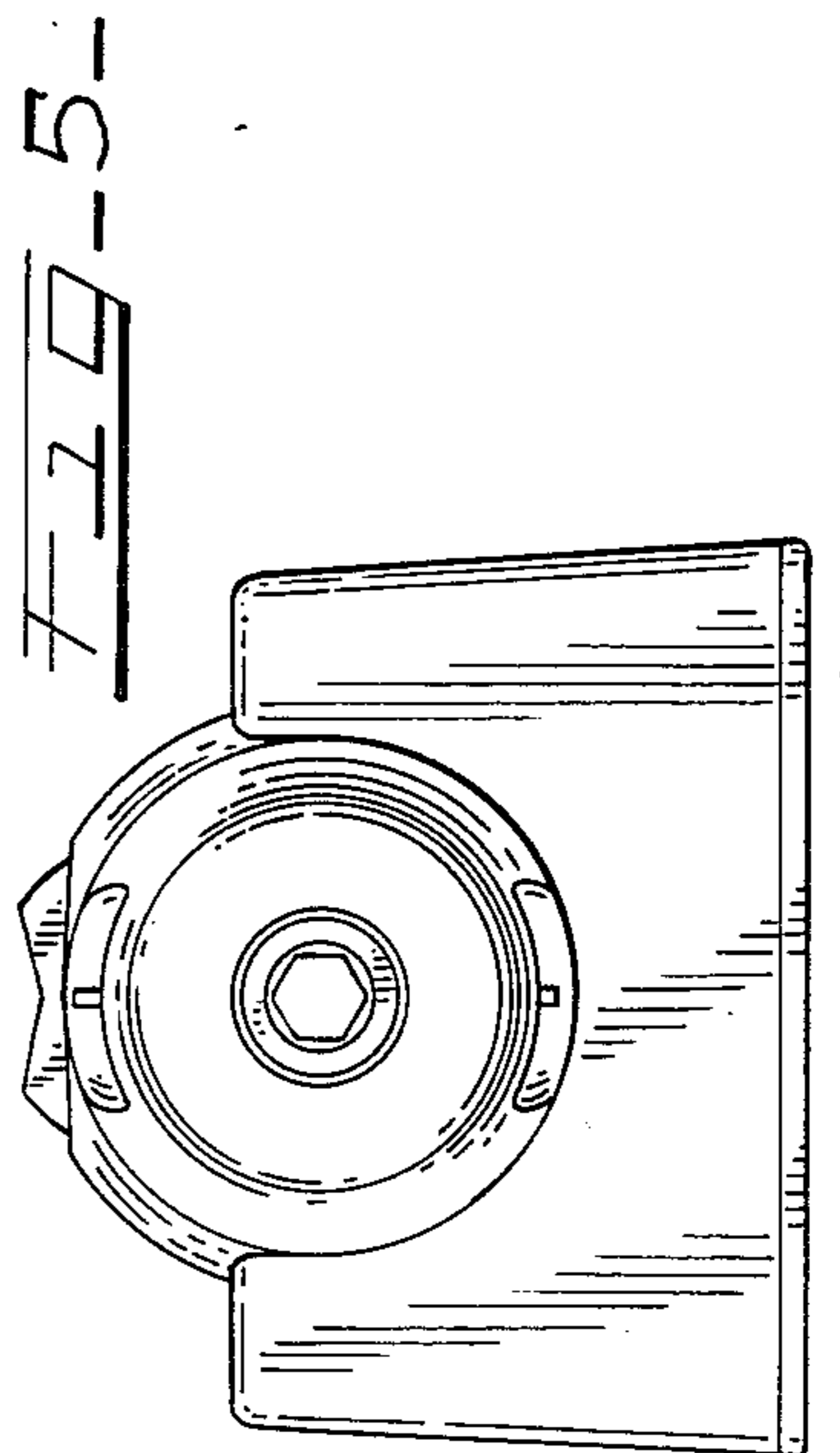

FIG. 5-