

[54] **FOLDABLE BENCH AND DRAWING BOARD COMBINATION**

[76] **Inventor: Betty Osborne, 114½ W. Lexington Ave., Elkhart, Ind. 46516**

[**] **Term: 14 Years**

[21] **Appl. No.: 805,997**

[22] **Filed: Nov. 21, 1985**

[52] **U.S. Cl. D6/340; D6/300; D6/338**

[58] **Field of Search D6/300, 335, 336, 337, D6/338, 340, 367, 368, 429, 430, 420**

[56]

References Cited

U.S. PATENT DOCUMENTS

D. 61,355	8/1922	Anderson	D6/340
D. 140,281	2/1945	Weller et al.	D6/340
D. 169,012	3/1953	Musacco	D6/338
D. 175,016	6/1955	Cote	D6/340
D. 182,061	2/1958	Cote	D6/340
D. 260,203	8/1981	Arnold	D6/354 X

Primary Examiner—Bruce W. Dunkins

[57]

CLAIM

The ornamental design for a foldable bench and drawing board combination, as shown and described.

DESCRIPTION

FIG. 1 is a perspective view of a foldable bench and drawing board combination showing my design; FIG. 2 is a side perspective view; FIG. 3 is an end perspective view; and, FIG. 4 is a perspective view thereof in folded condition.

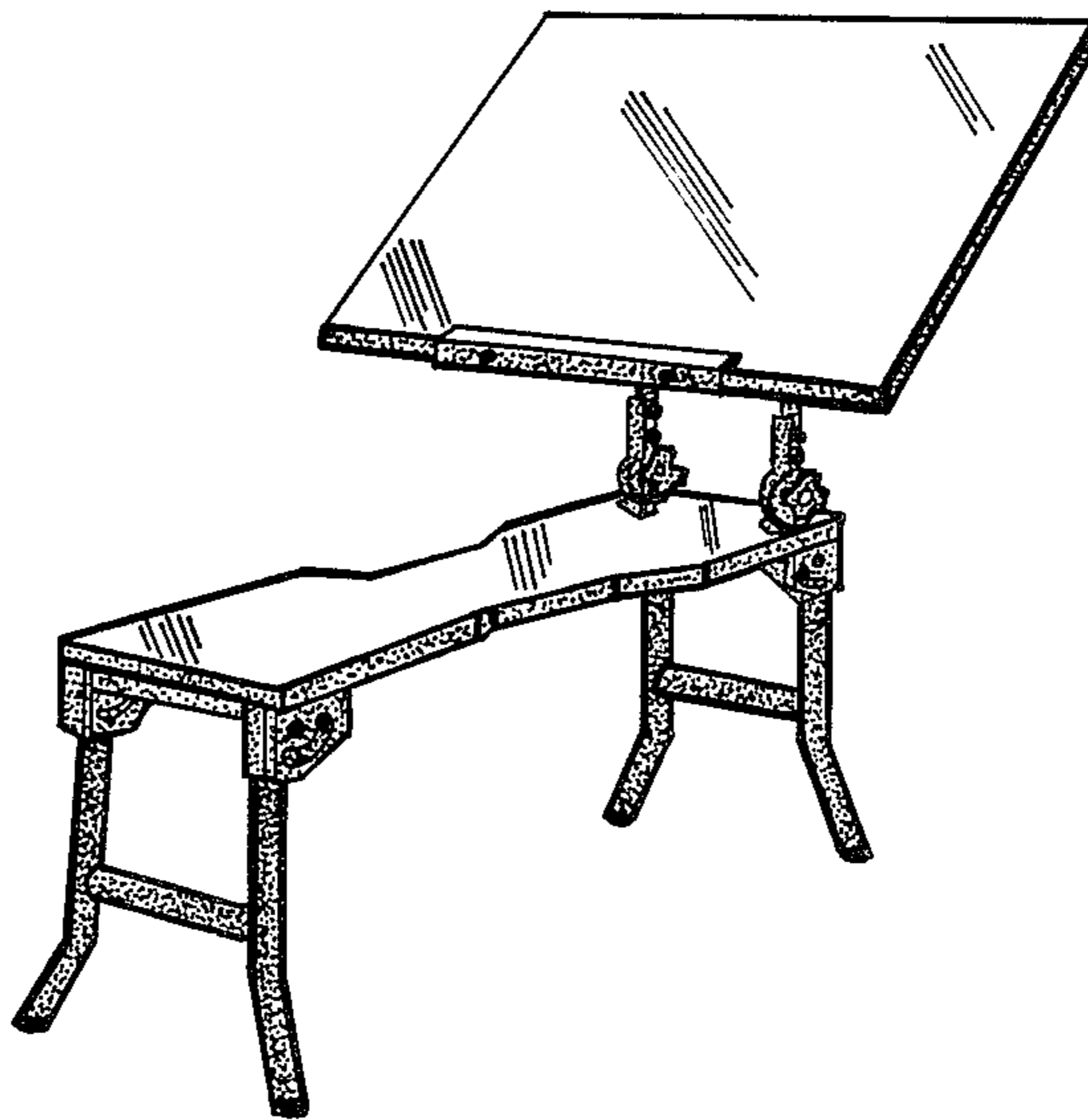

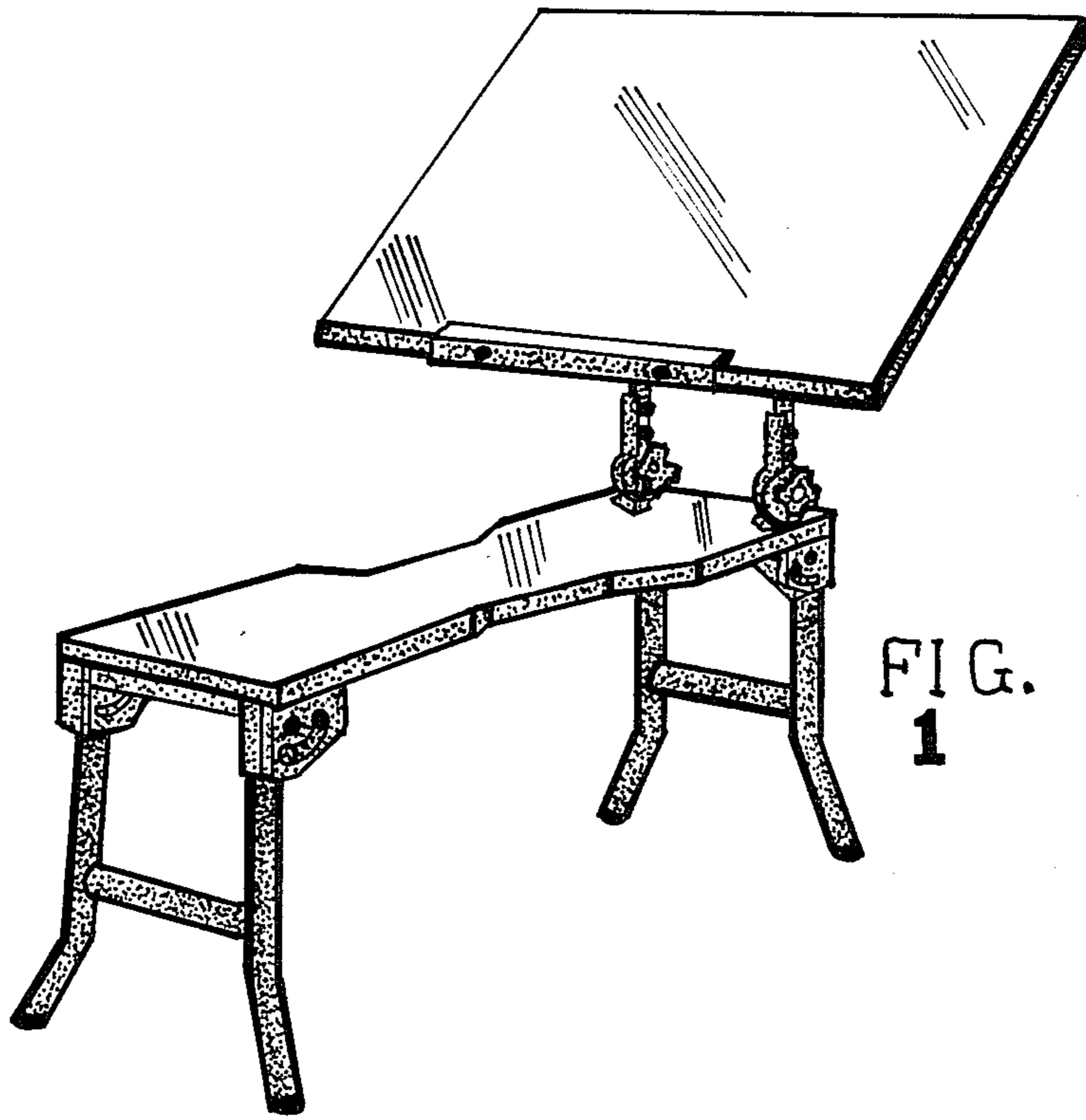

FIG.
1

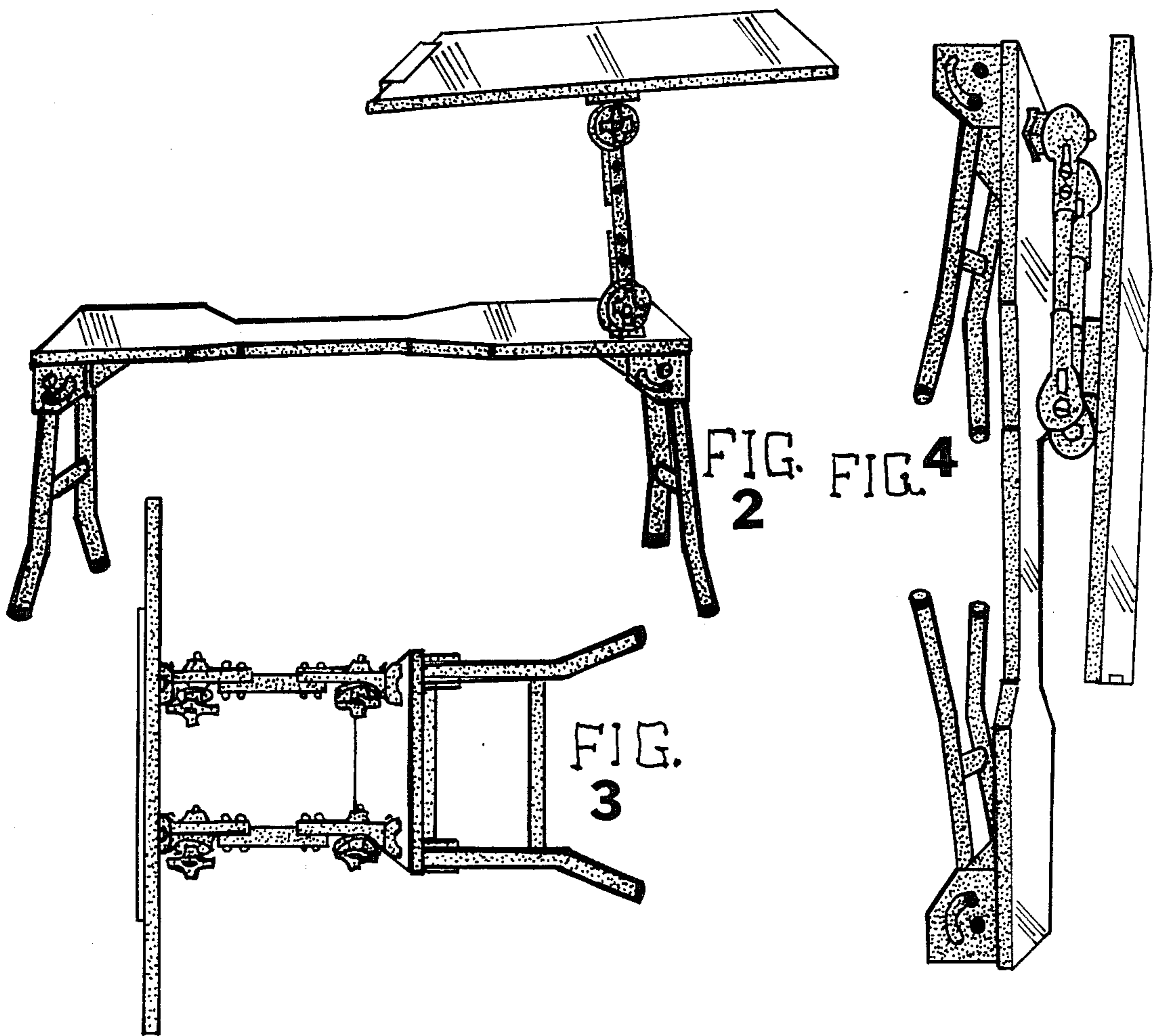

FIG.
2

FIG. 4

FIG.
3