

[54] **ELECTRONIC MUSICAL PERCUSSION PAD**

[76] **Inventor: Brock Seiler, 5 E. 22nd St., New York, N.Y. 10010**

[**] **Term: 14 Years**

[21] **Appl. No.: 851,367**

[22] **Filed: Apr. 10, 1986**

[52] **U.S. Cl. D17/22**

[58] **Field of Search D17/22, 99; 84/411, 84/411 A, 411 M, 411 P, 419, 420, 421**

[56] **References Cited**

U.S. PATENT DOCUMENTS

D. 285,453	9/1986	Hoshino	D17/22
3,186,290	6/1965	Gould et al.	84/411 P
4,179,974	12/1979	Trankle	84/411 P
4,581,972	4/1986	Hoshino	84/1.14
4,581,973	4/1986	Hoshino	84/DIG. 12 X

OTHER PUBLICATIONS

The Music Trades, Jun. 1985, p. 103, top left—M.P.C. 'Super' Pads.

Primary Examiner—Bernard Ansher
Assistant Examiner—Theodore M. Shooman
Attorney, Agent, or Firm—Roger S. Thompson

[57] **CLAIM**

The ornamental design for an electronic musical percussion pad, as shown.

DESCRIPTION

FIG. 1 is a top plan view of an electronic musical percussion pad showing my new design;
FIG. 2 is a front elevational view thereof;
FIG. 3 is a right side elevational view thereof;
FIG. 4 is a left side elevational view thereof;
FIG. 5 is a rear elevational view thereof; and
FIG. 6 is a bottom plan view thereof.

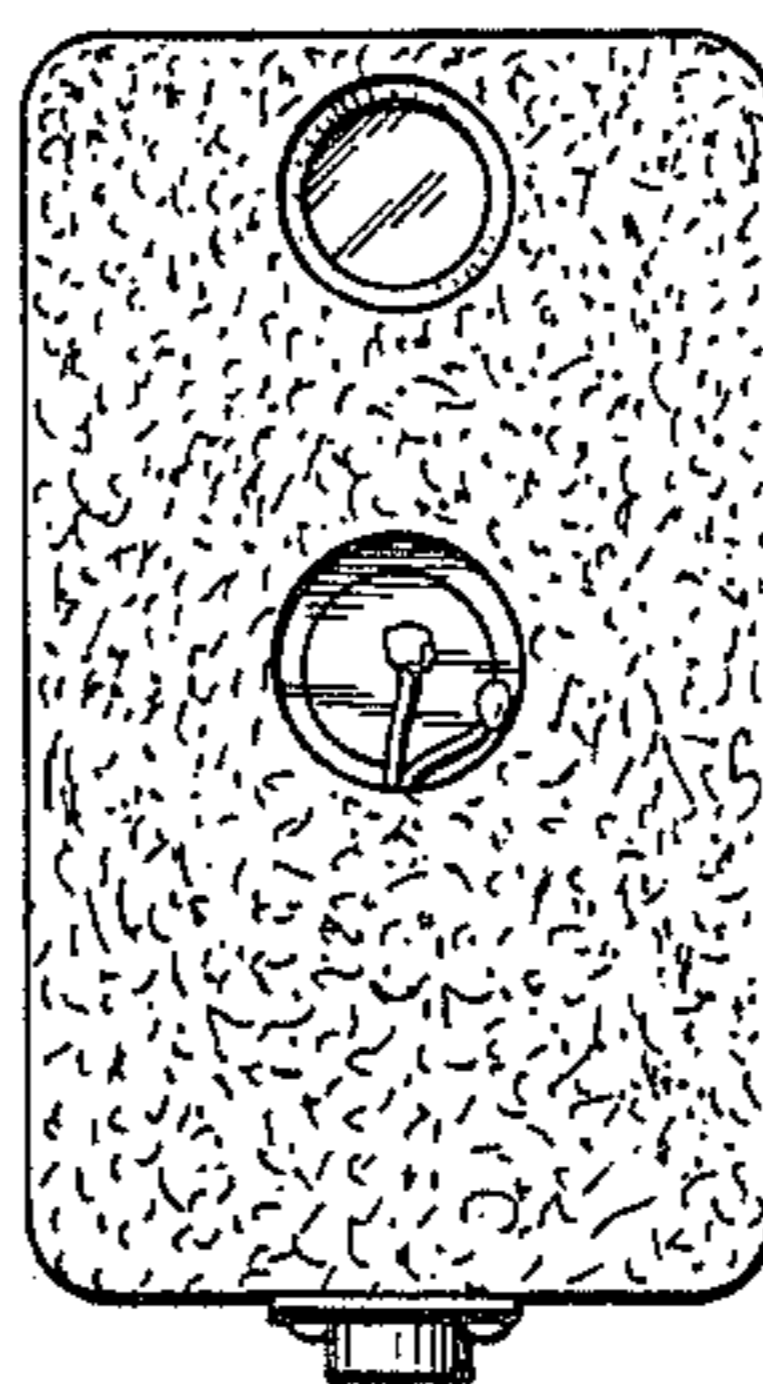
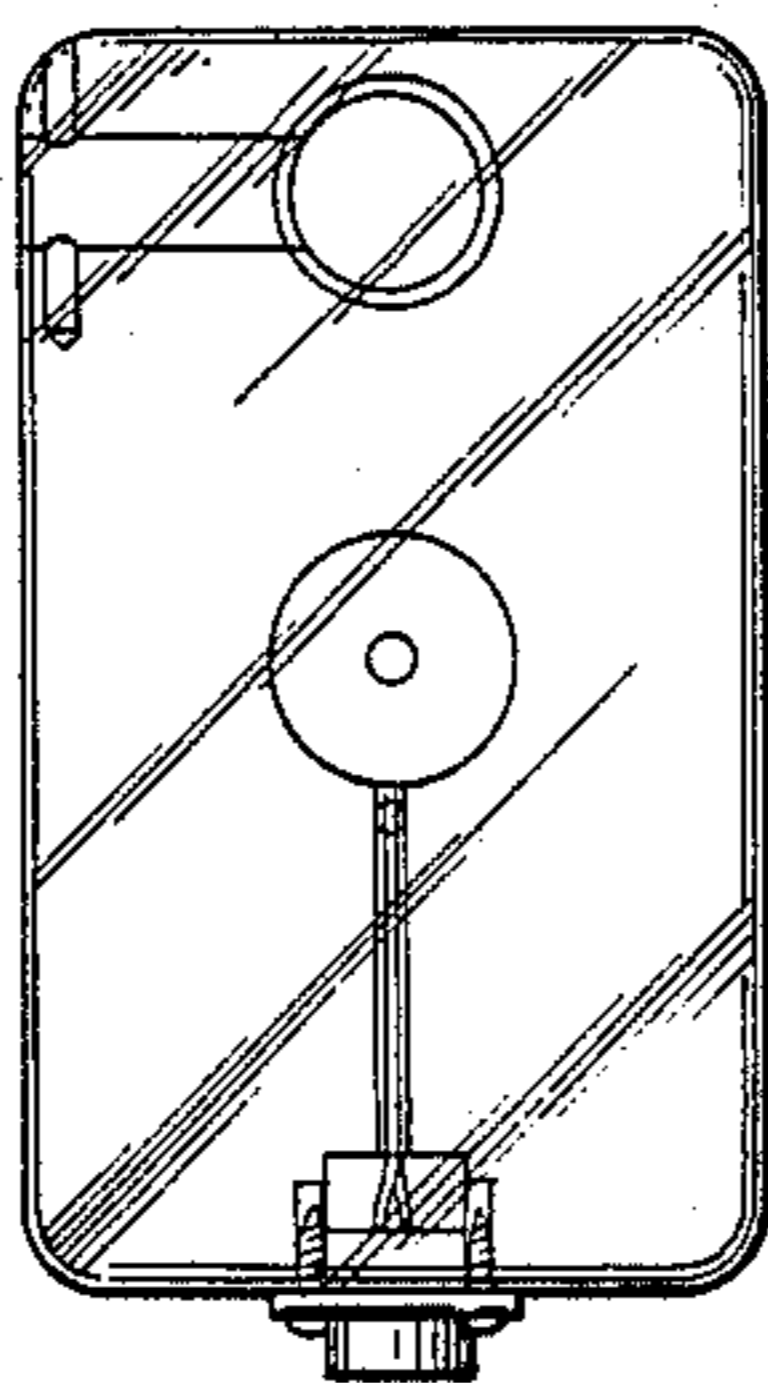

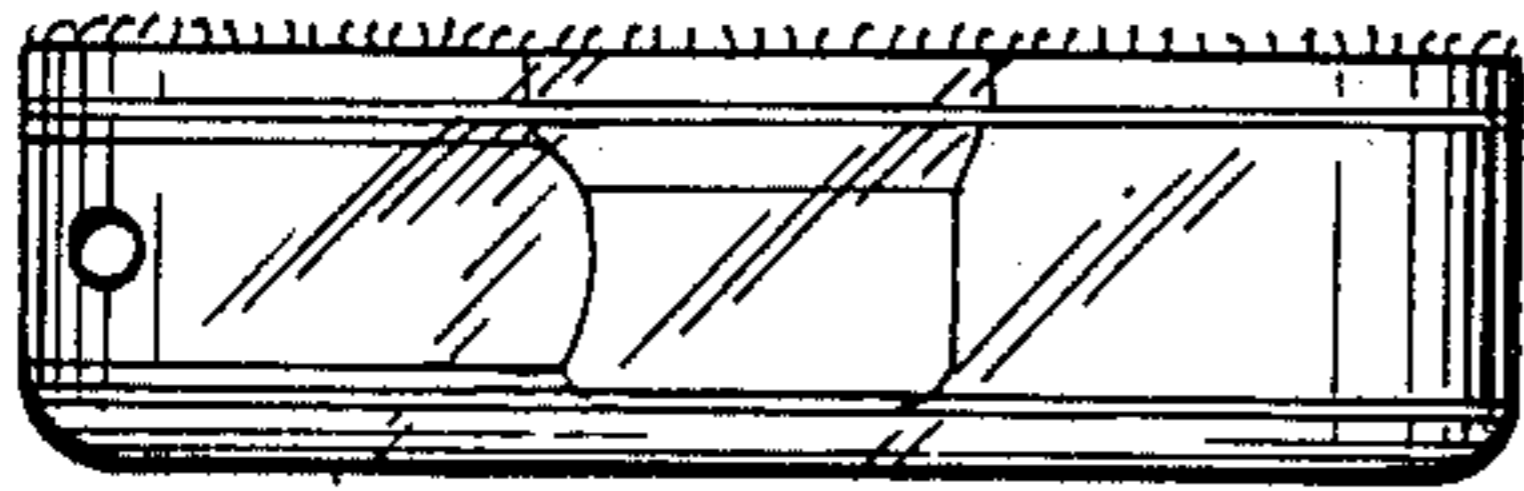

FIG. 1

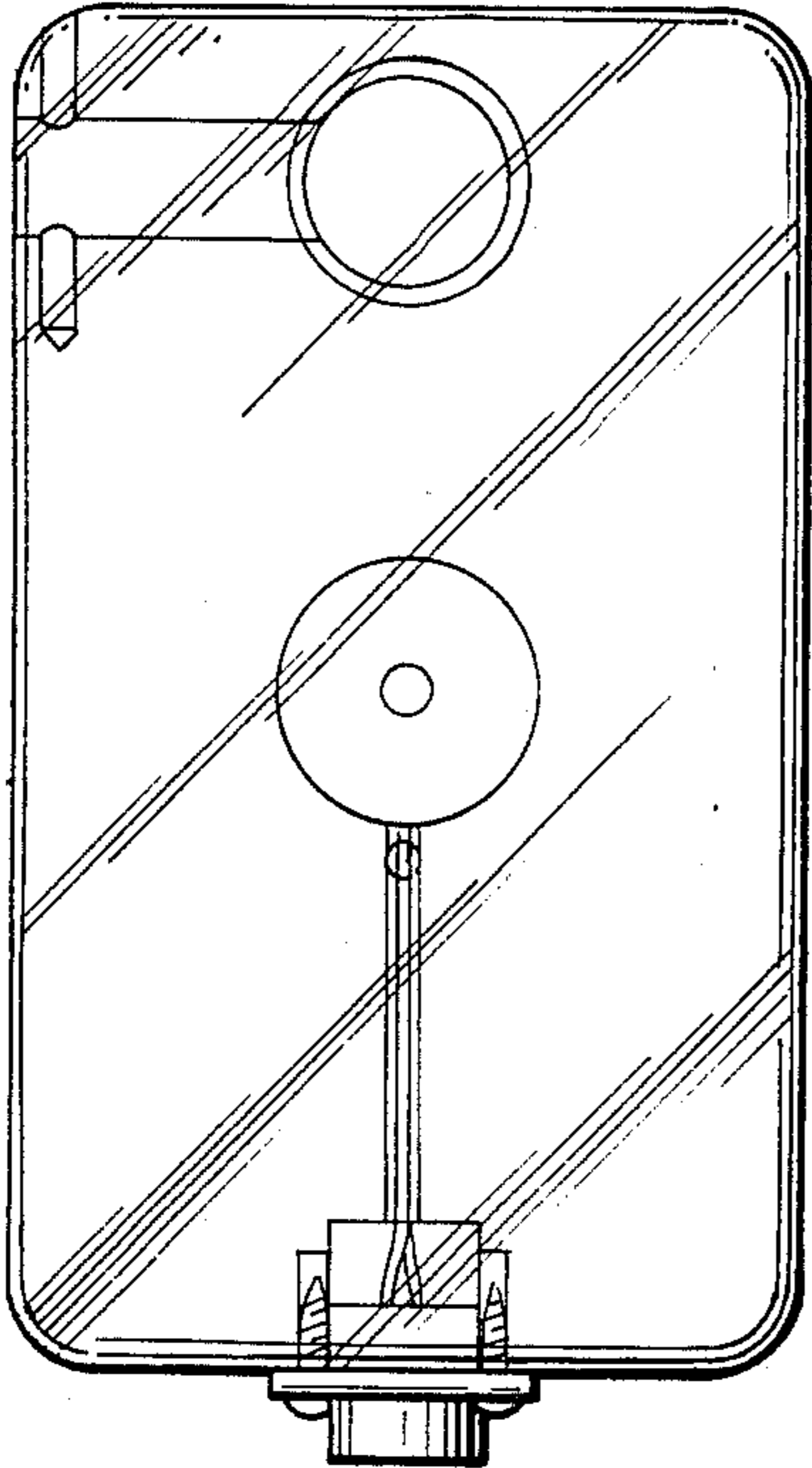

FIG. 2

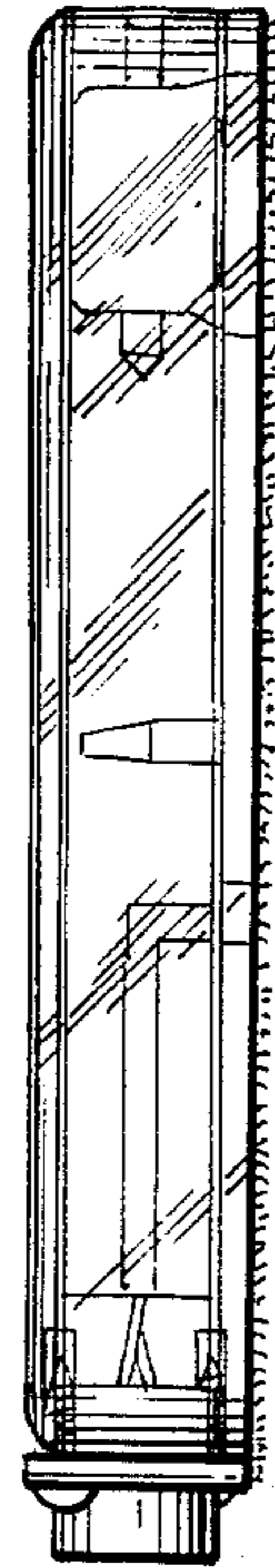

FIG. 3

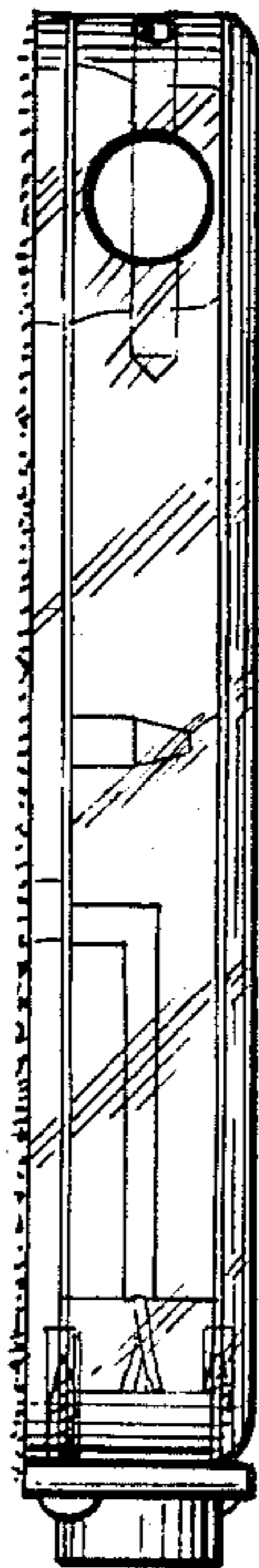

FIG. 4

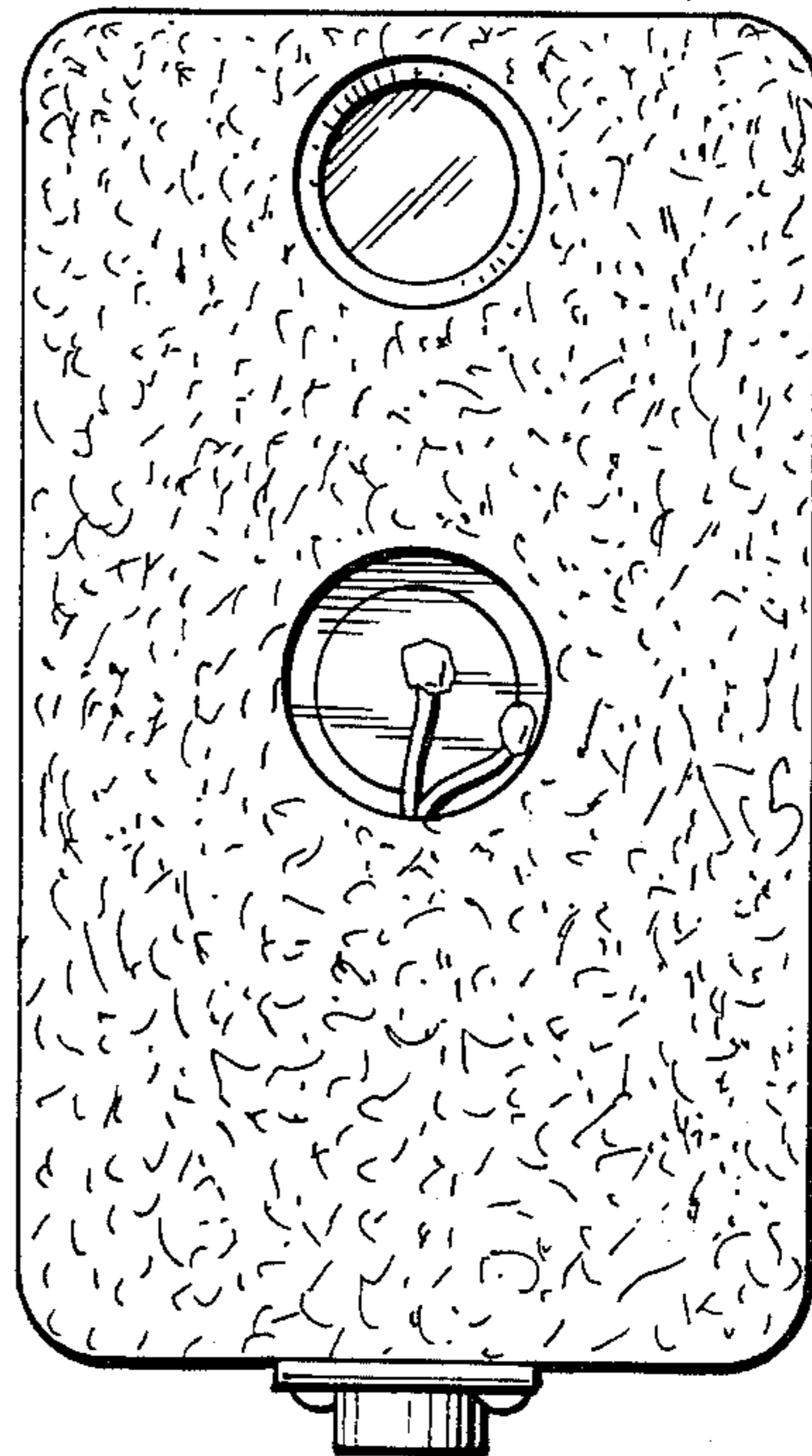

FIG. 5

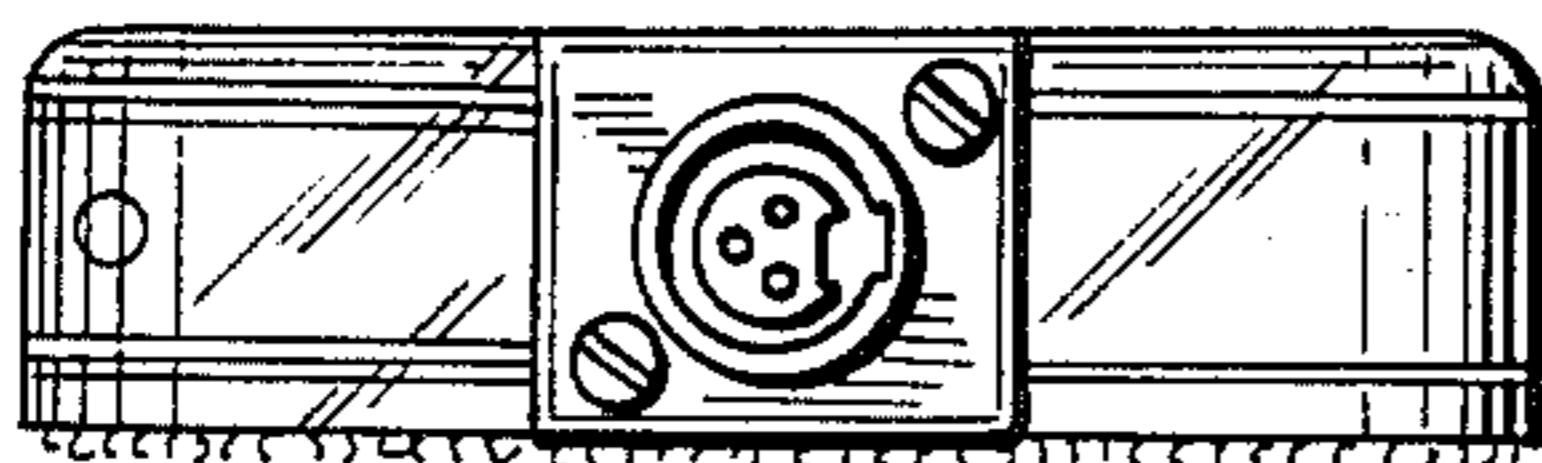

FIG. 6