

[54] CART FOR TRANSPORTING PEOPLE

[76] Inventor: Albert V. Fragione, Jr., 24 Filley St., Bloomfield, Conn. 06002

[**] Term: 14 Years

[21] Appl. No.: 791,796

[22] Filed: Oct. 28, 1985

[52] U.S. Cl. D12/19; D34/24

[58] Field of Search D34/24, 26; D12/17, D12/18, 19, 20; 280/63, 47, 25

[56] References Cited

U.S. PATENT DOCUMENTS

D. 157,944	4/1950	Dammeyer	D12/19
D. 186,709	11/1959	See	D12/19
D. 191,037	8/1961	Mayberry	D12/19
D. 192,140	1/1962	Huskey	D12/19
D. 229,985	1/1974	Trevena	D12/19
D. 248,226	6/1978	Sailer, Sr.	D34/24
D. 276,902	12/1984	Plugge	D12/19
4,470,610	9/1984	Wilson	280/47.25

4,667,973	5/1987	Bowers	280/63
4,671,522	6/1987	Fragione, Jr.	280/63

Primary Examiner—Wallace R. Burke
Assistant Examiner—Kay H. Chin
Attorney, Agent, or Firm—McCormick, Paulding & Huber

[57] CLAIM

The ornamental design for a cart for transporting people, as shown and described.

DESCRIPTION

FIG. 1 is a front perspective view of a cart for transporting people showing my new design.
FIG. 2 is a rear perspective view thereof.
FIG. 3 is a side perspective view thereof, the opposite side being a mirror image thereof.
FIG. 4 is a front elevational view thereof.
FIG. 5 is a rear elevational view of a cart for transporting people showing a second embodiment, the sole difference from the first embodiment being in the canopy and the carrying basket attached under the seat.

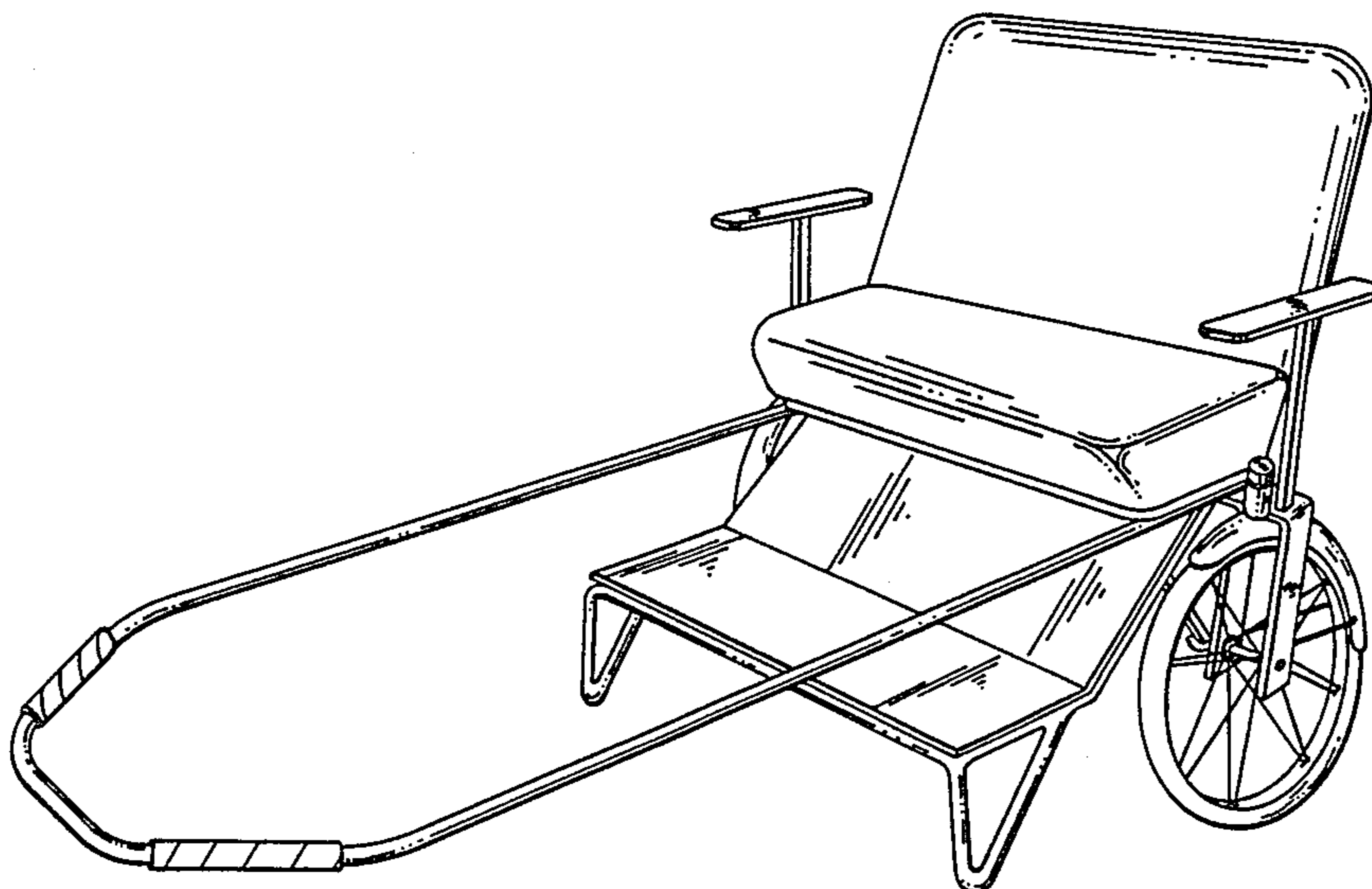

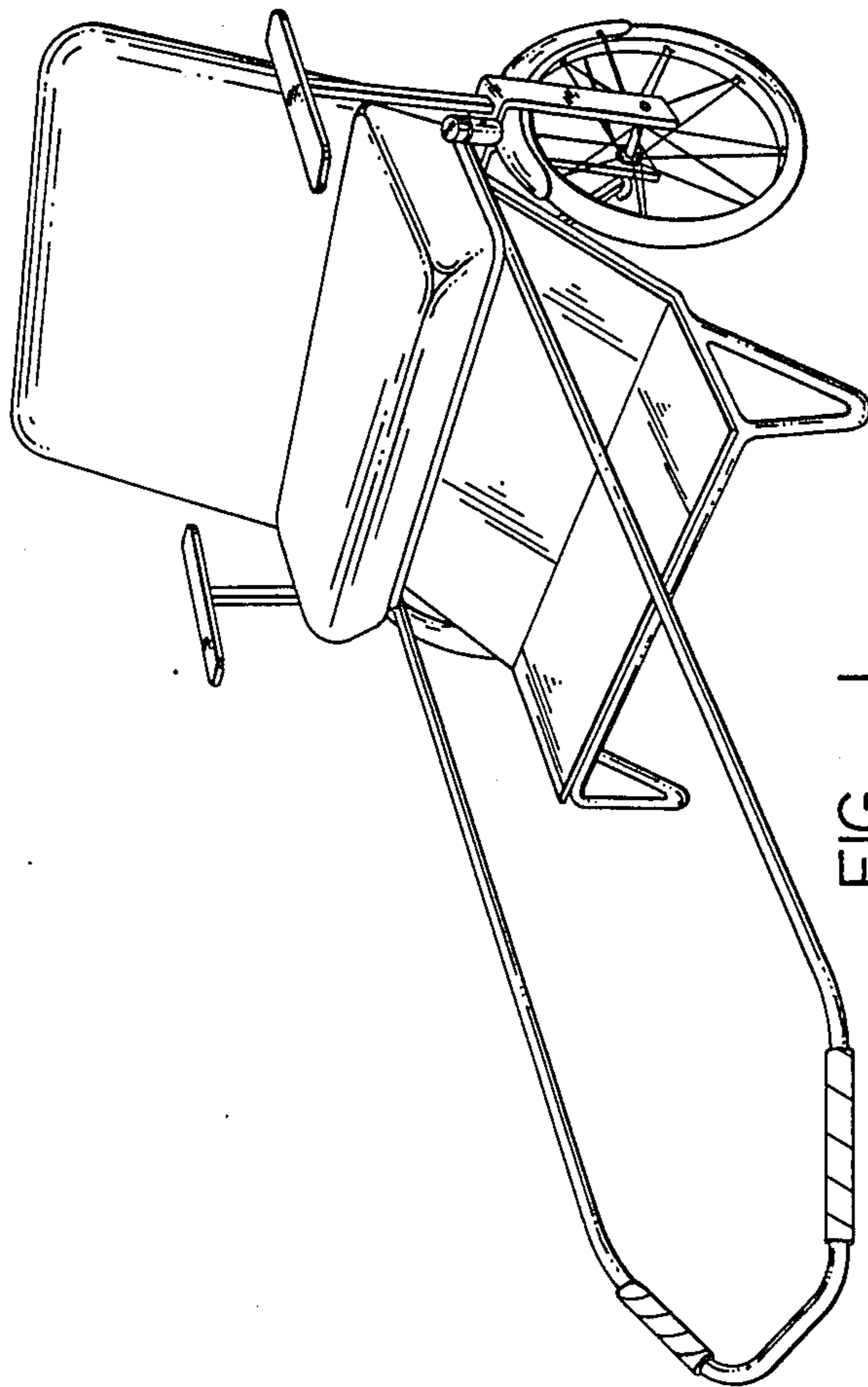

FIG. 1

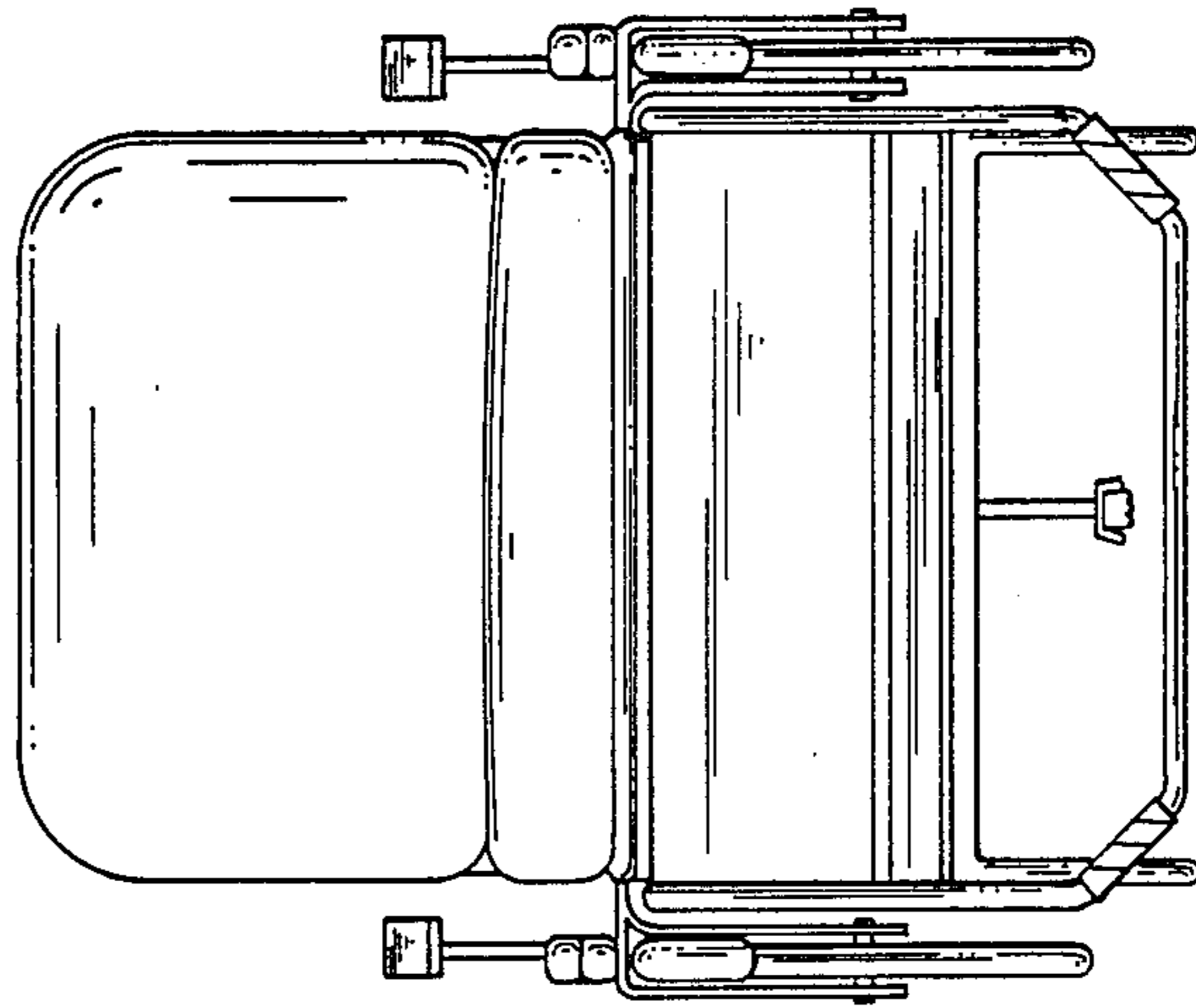

FIG. 4

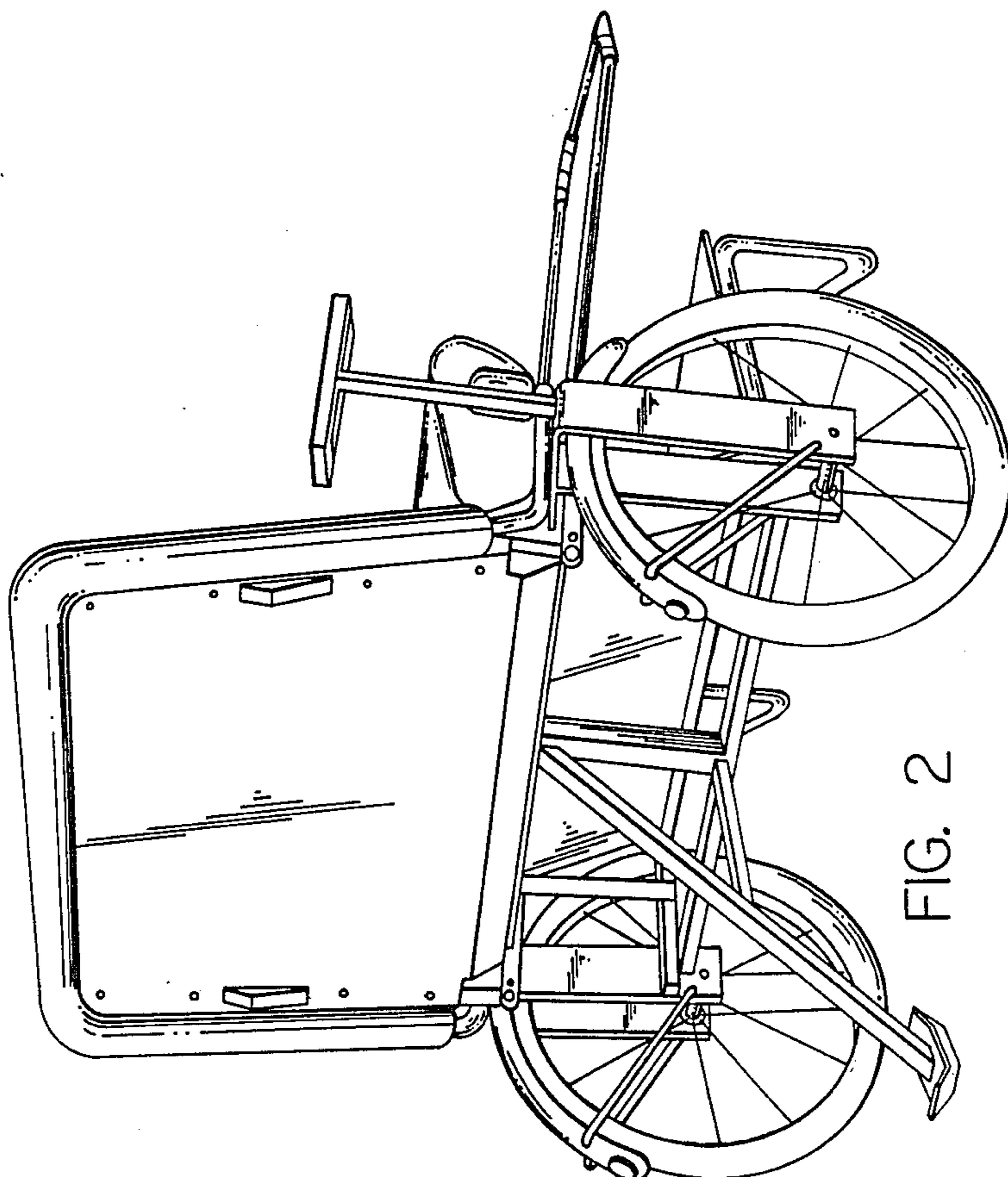

FIG. 2

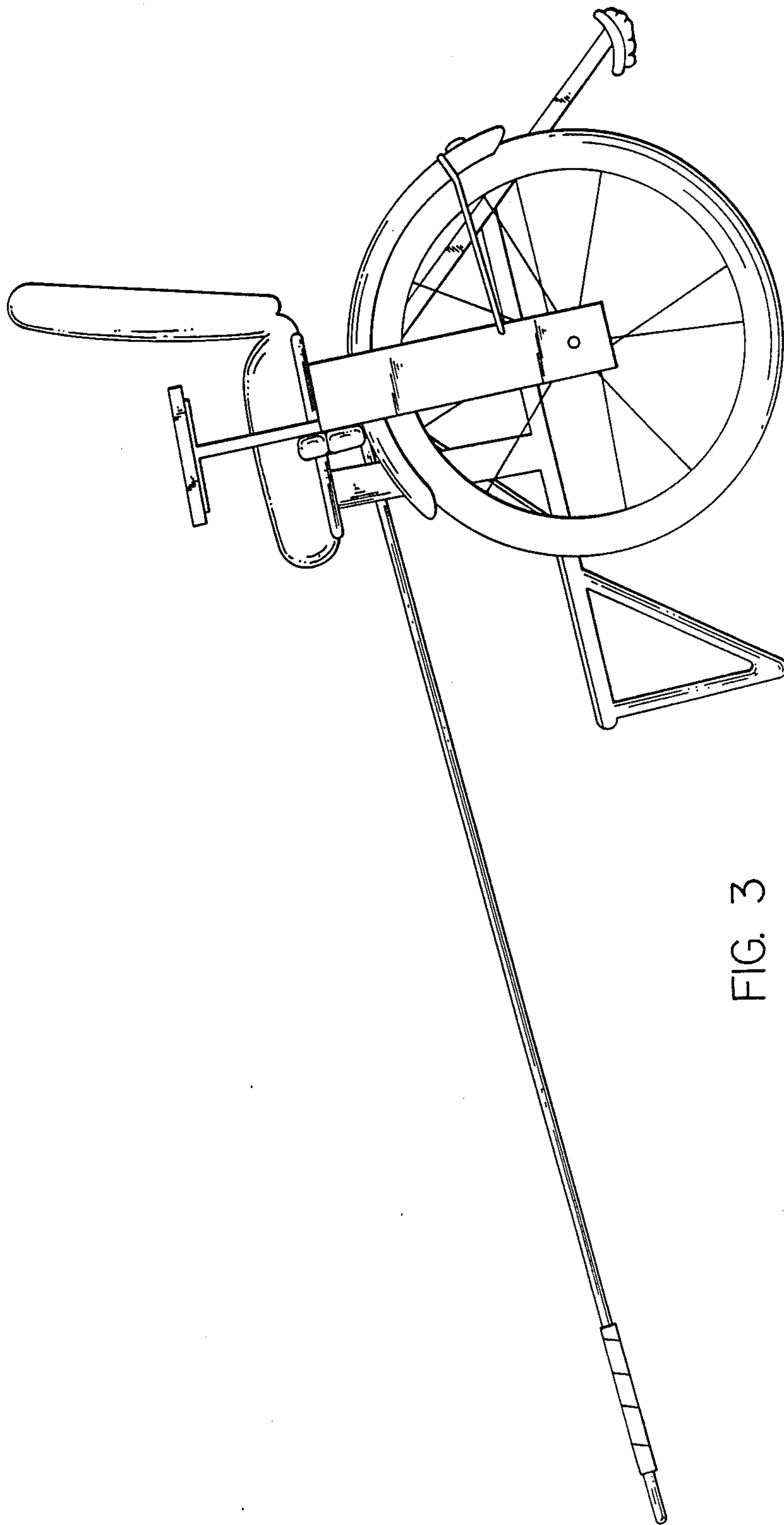

FIG. 3

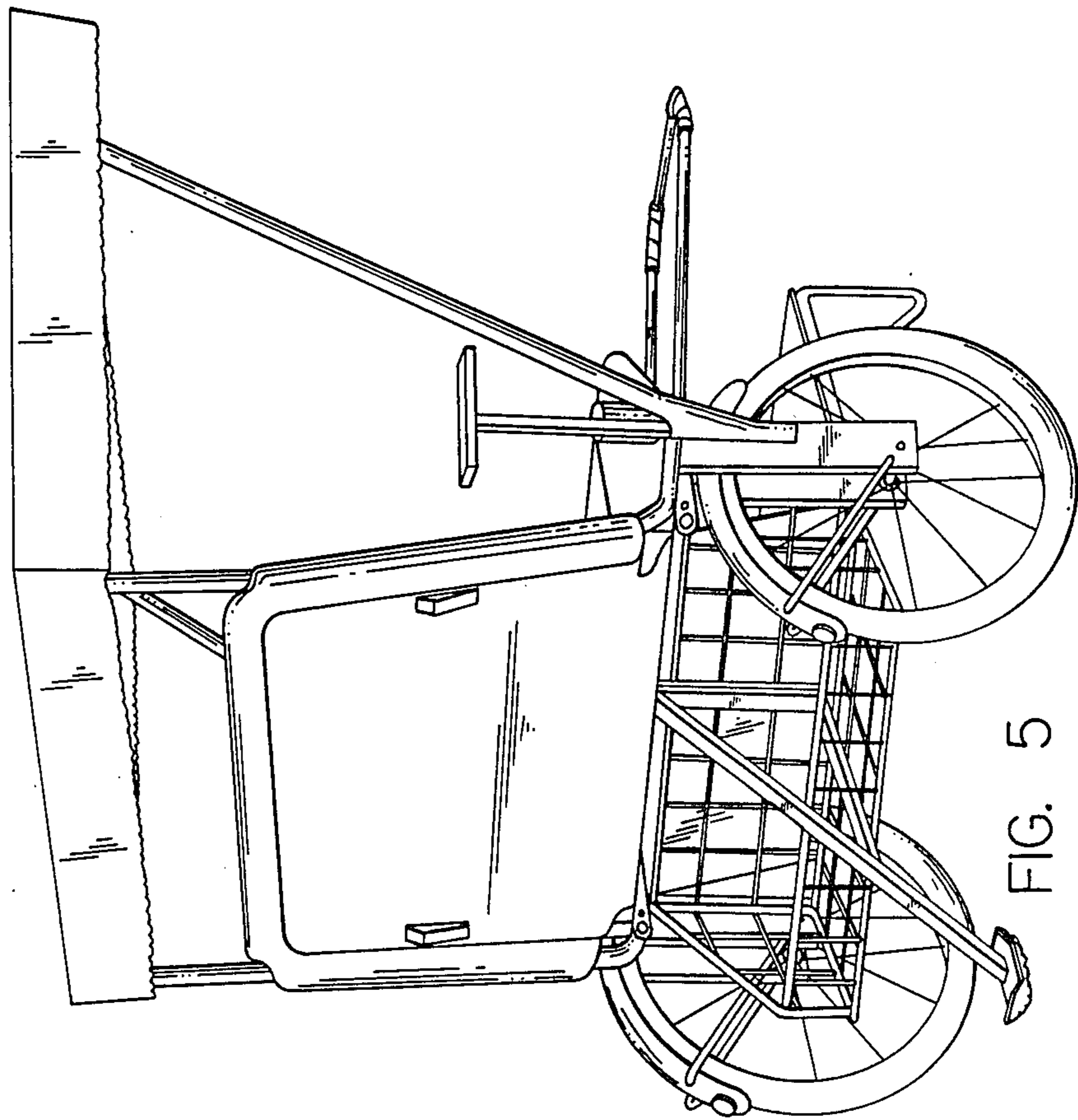

FIG. 5