

[54] TRAILER REAR DOOR LOCK  
[75] Inventor: David Falk, Richfield, Minn.  
[73] Assignee: Transport Security, Inc., Chanhassen, Minn.  
[\*\*] Term: 14 Years  
[21] Appl. No.: 889,279  
[22] Filed: Jul. 25, 1986  
[52] U.S. Cl. .... D8/331  
[58] Field of Search ..... D8/330-331,  
D8/333-334, 338, 341; 70/57, 91, 97, 237;  
292/DIG. 23, DIG. 32

4,045,982 9/1977 Gorton et al. .... 70/90  
4,709,949 12/1987 Umezawa et al. .... 292/DIG. 38 X

Primary Examiner—Wallace R. Burke  
Assistant Examiner—Brian N. Vinson  
Attorney, Agent, or Firm—Hugh D. Jaeger

[57] CLAIM

The ornamental design for a trailer rear door lock, as shown.

DESCRIPTION

FIG. 1 is a bottom front perspective view of a trailer rear door lock showing my new design; FIG. 2 is a right side elevational view thereof; FIG. 3 is a front elevational view thereof; FIG. 4 is a left side elevational view thereof; FIG. 5 is a top plan view thereof; FIG. 6 is a rear elevational view thereof; and FIG. 7 is a bottom plan view thereof.

[56] References Cited  
U.S. PATENT DOCUMENTS  
D. 281,220 11/1985 Lassiter ..... D8/331  
3,848,911 11/1974 Watermann et al. .... 292/341.12 X

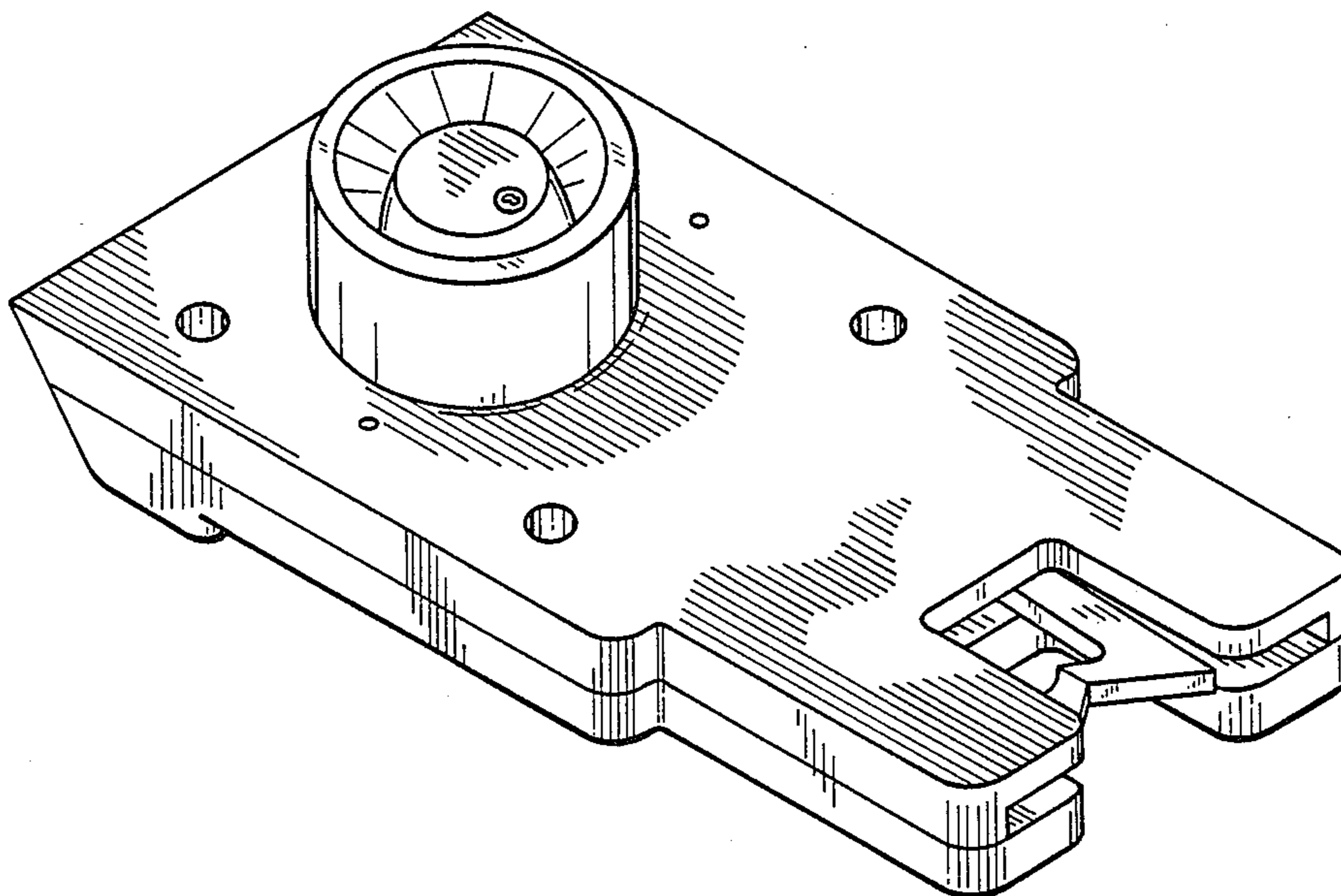

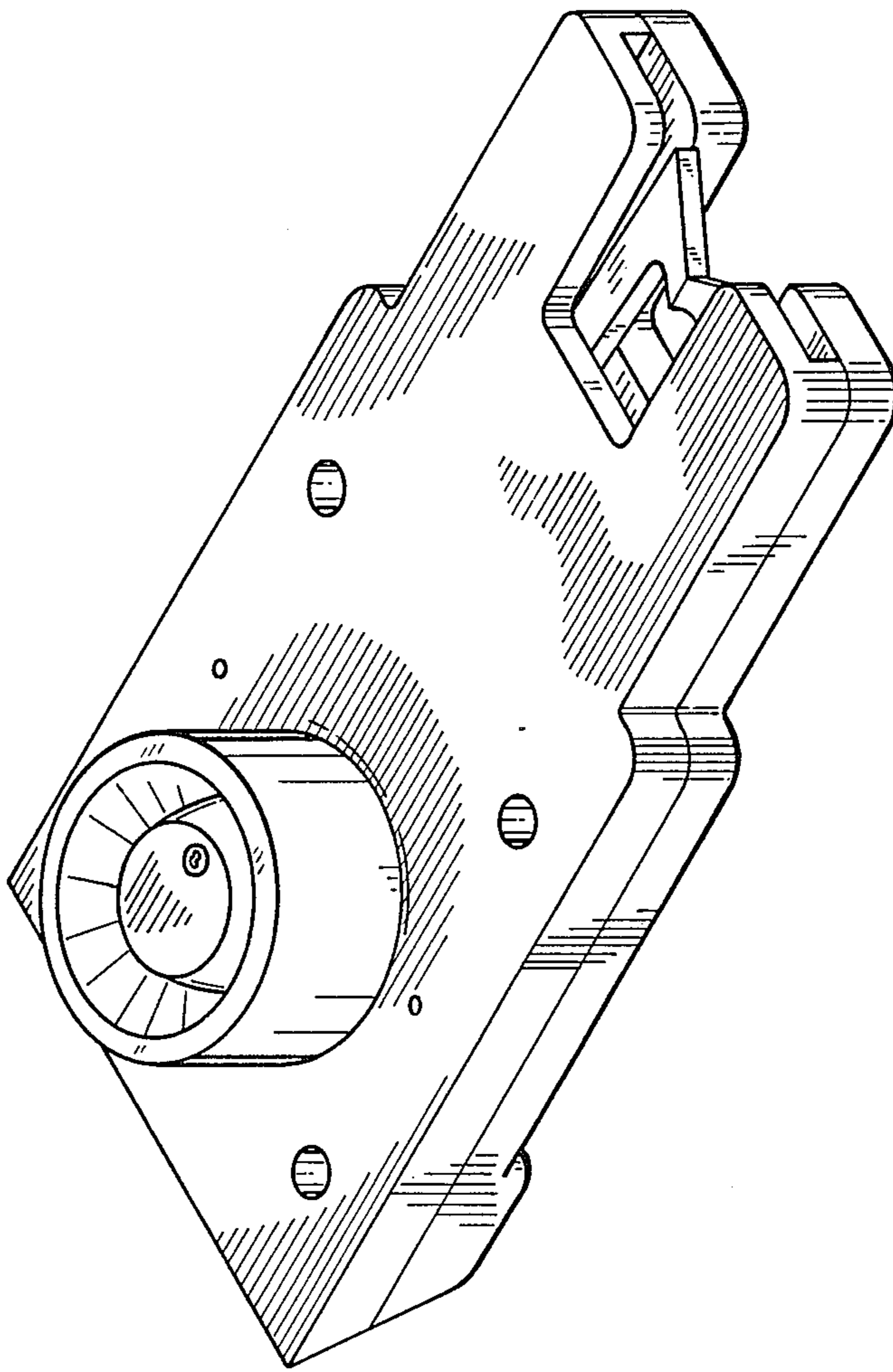

FIG. 1

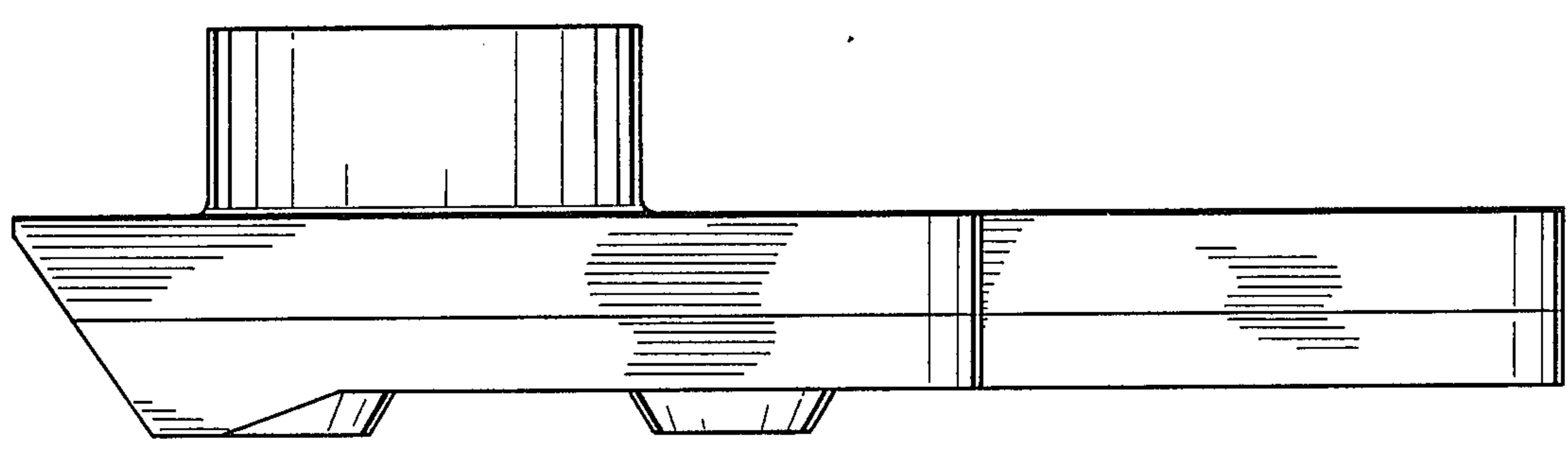

FIG. 4

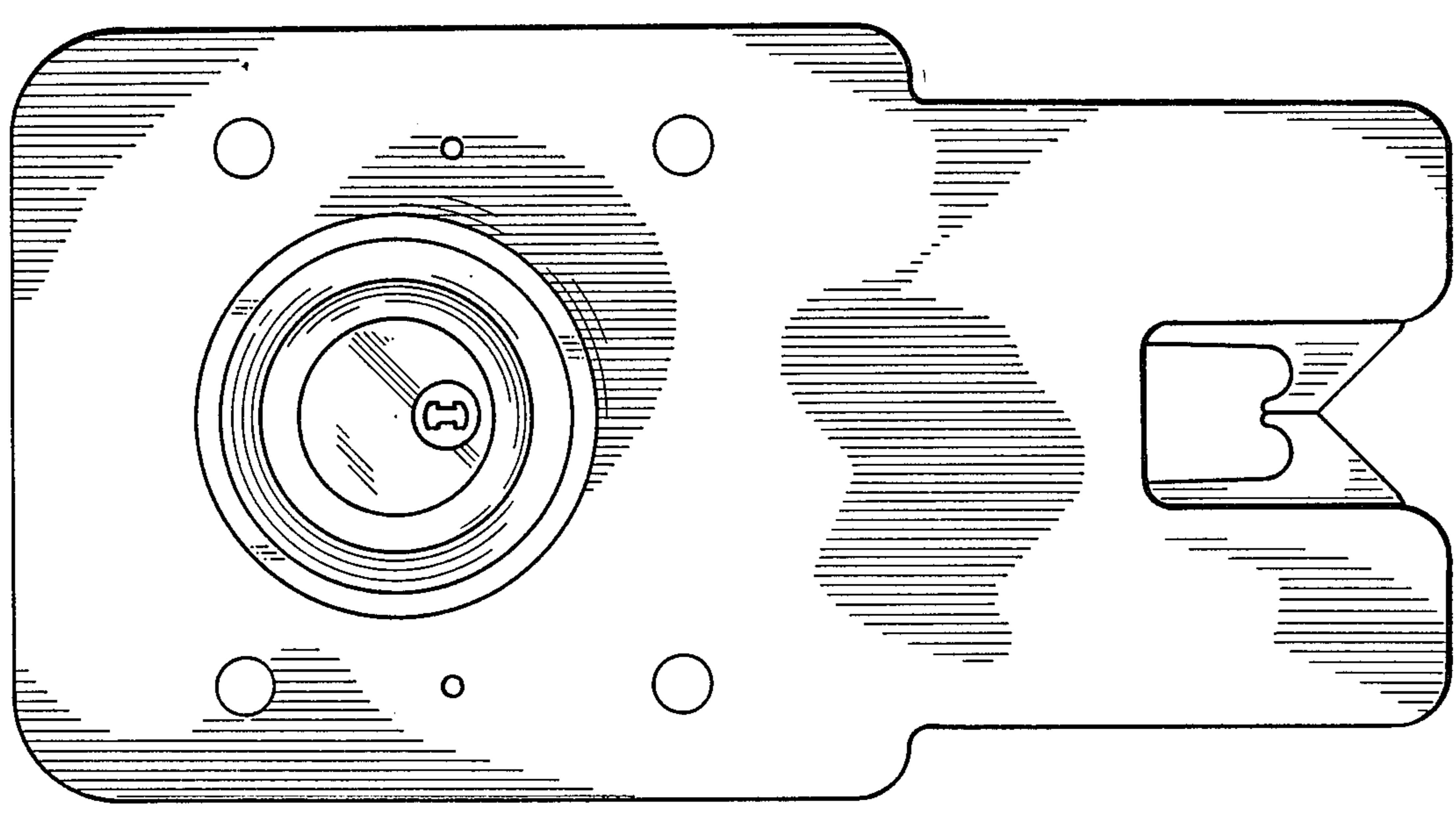

FIG. 3

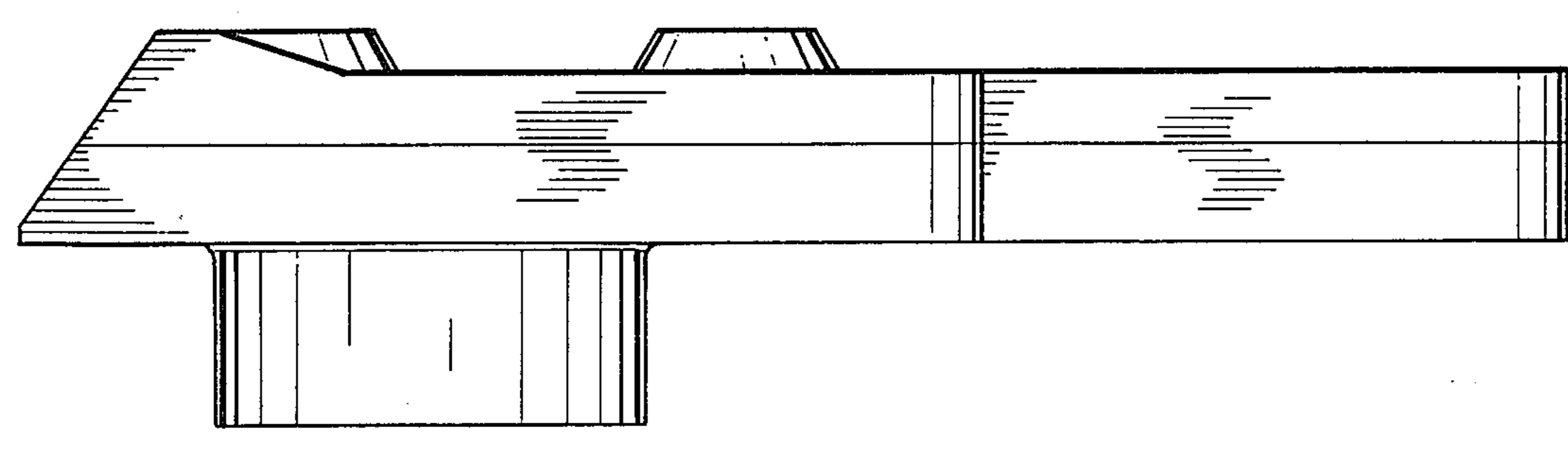

FIG. 2

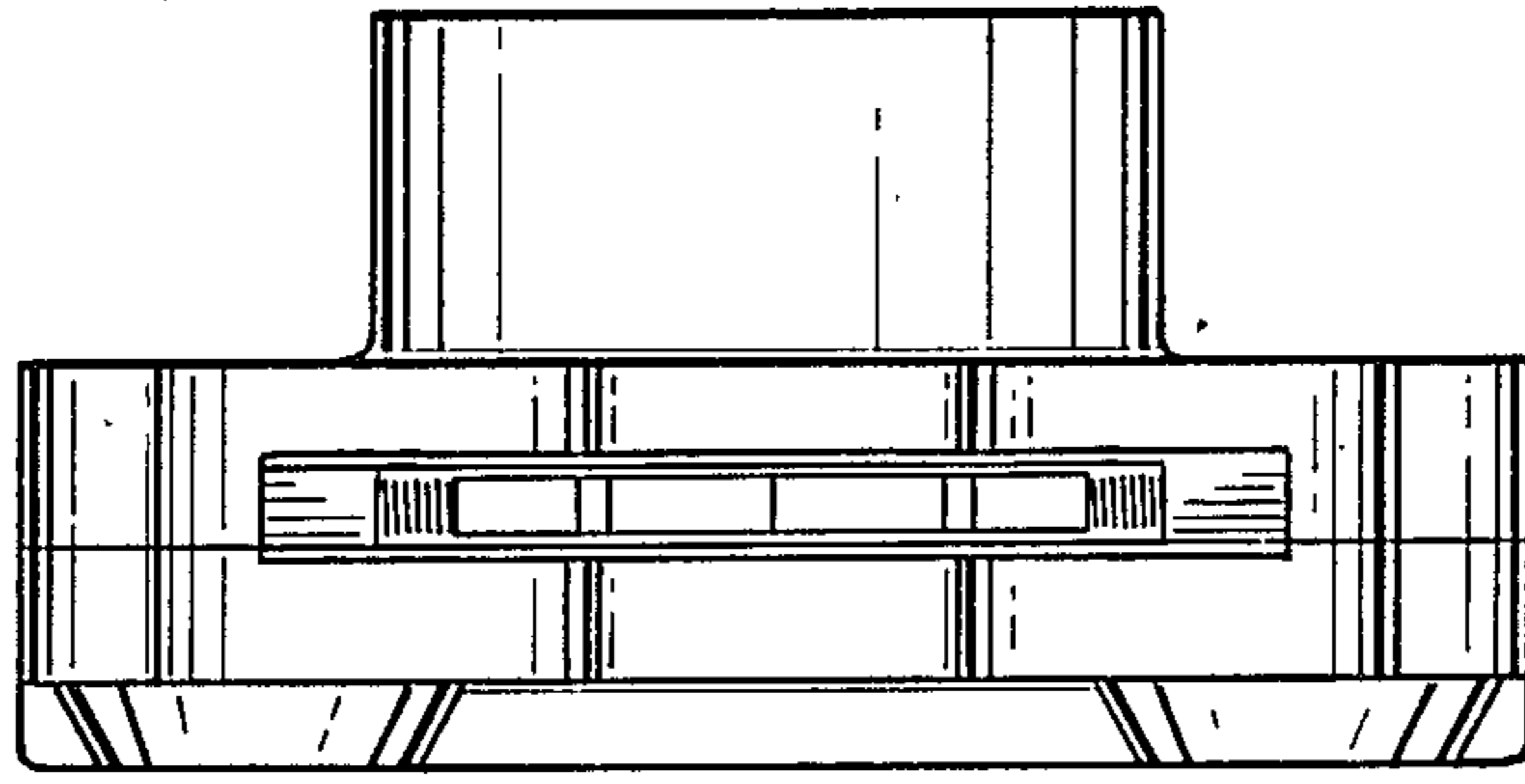

FIG. 7

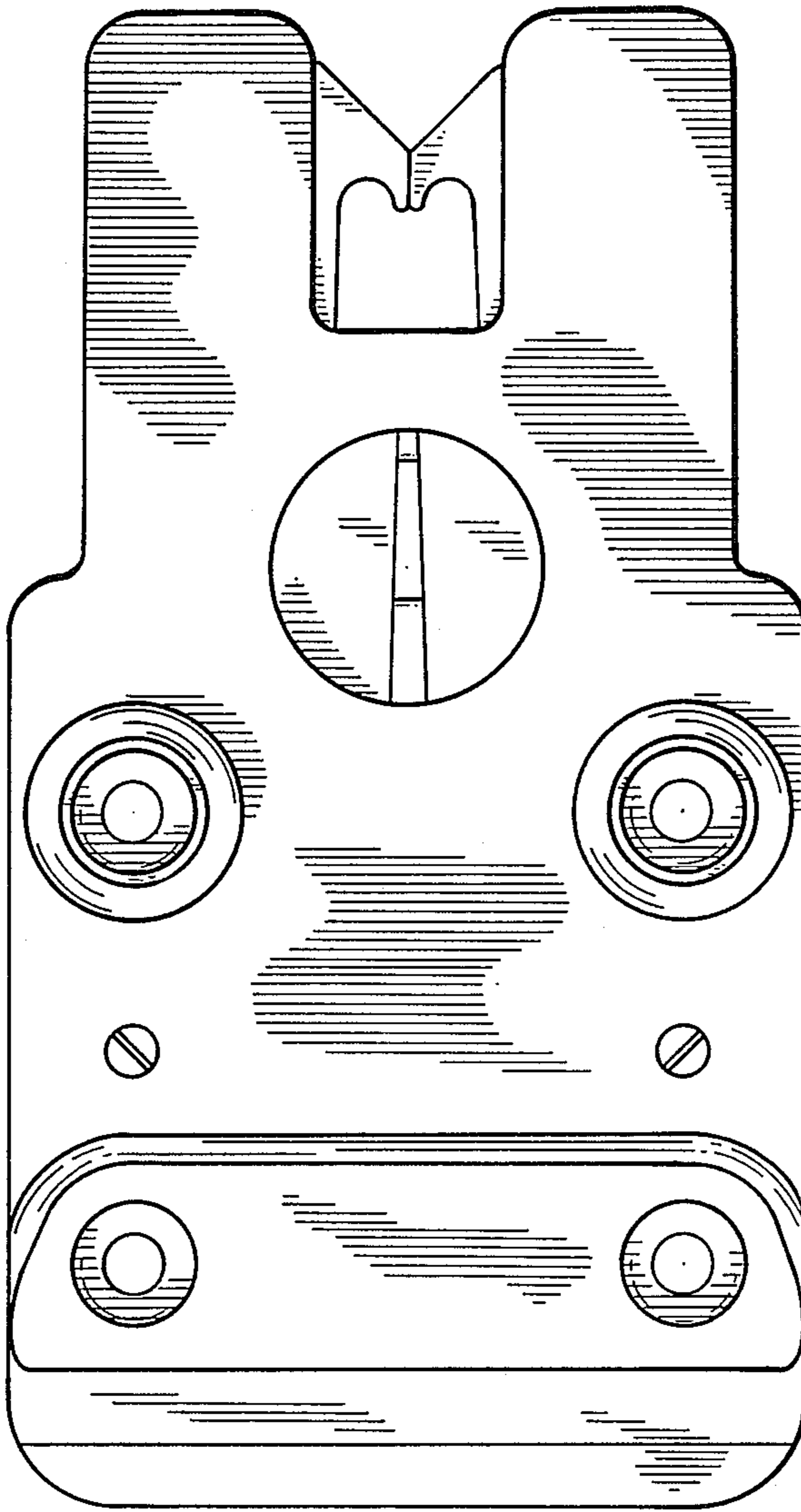

FIG. 6

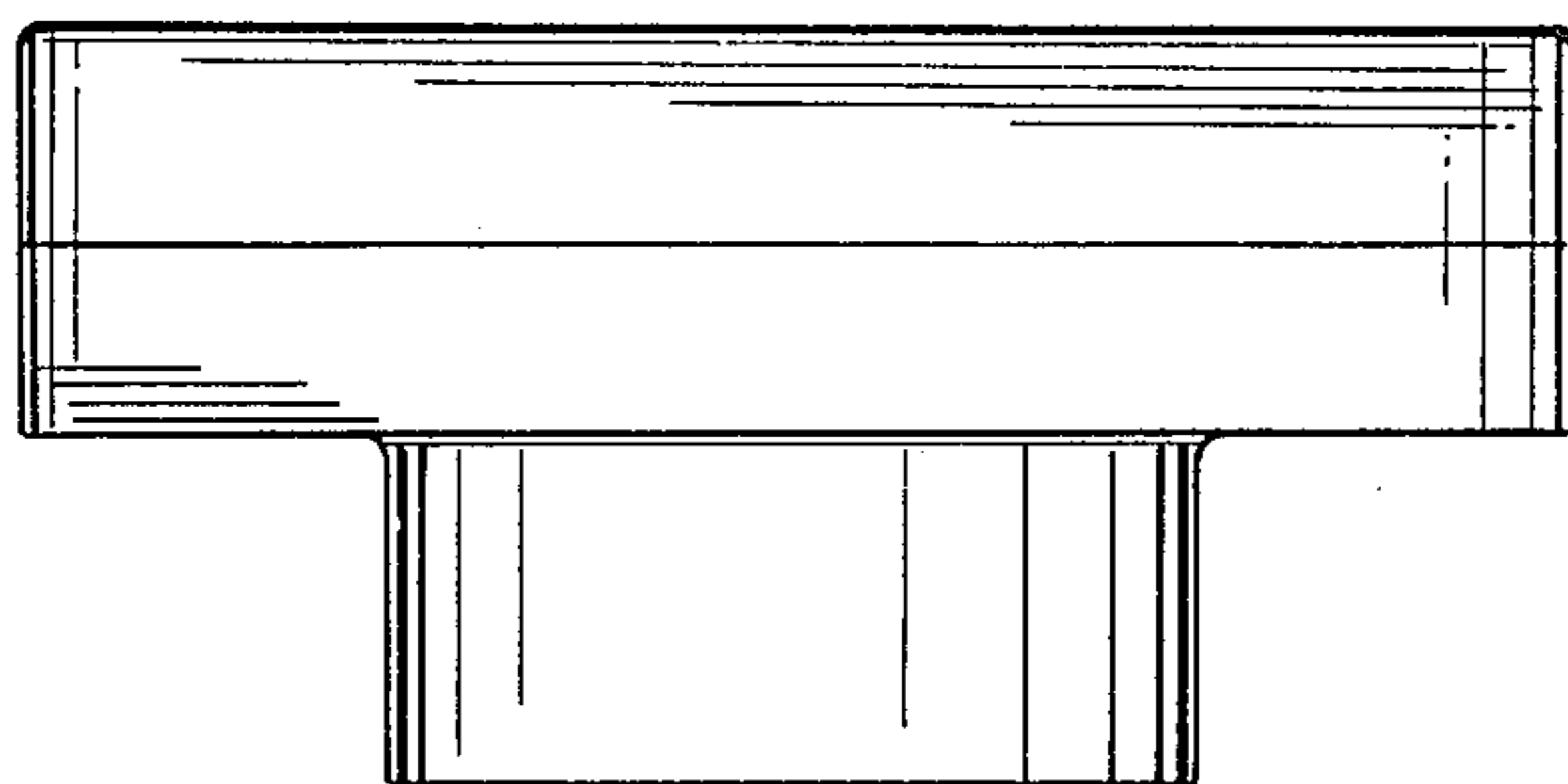

FIG. 5