

[54] TRACTOR

[75] Inventors: Shigeru Morita; Hisato Katoh; Yoshihiro Kawahara; Kenkichi Nosaka, all of Sakai, Japan

[73] Assignee: Kubota, Ltd., Sakai, Japan

[**] Term: 14 Years

[21] Appl. No.: 854,751

[22] Filed: Apr. 21, 1986

[52] U.S. Cl. D15/23

[58] Field of Search D15/10-12, D15/15, 22-23, 25-26, 28, 30-33; 180/89.12, 89.1, 89.19; 293/DIG. 1; 414/920, 685-687; 172/701.1, 811, 828; 37/103, DIG. 1; 56/320.1-320.2, DIG. 22, 13.4

[56] References Cited

U.S. PATENT DOCUMENTS

4,312,418	1/1982	Rittman	296/190
4,322,107	3/1982	Ishizuka et al.	180/89.1
4,392,669	7/1983	Martin, Jr.	296/190

FOREIGN PATENT DOCUMENTS

1604002 12/1981 United Kingdom 414/686

OTHER PUBLICATIONS

Implement & Tractor, vol. 97, Nov. 1982, p. 13, "Yanmar Tractor".

Primary Examiner—Wallace R. Burke
Assistant Examiner—Ruth Takemoto
Attorney, Agent, or Firm—Jordan and Hamburg

[57] CLAIM

The ornamental design of a tractor, as shown and described.

DESCRIPTION

FIG. 1 is a right side elevation view of a tractor showing our new design;
FIG. 2 is a left side elevational view thereof;
FIG. 3 is a top plan view thereof;
FIG. 4 is a front elevational view thereof; and
FIG. 5 is a rear elevational view thereof.
The tires shown in broken lines in FIGS. 1-5 are for illustrative purposes only and form no part of the claimed design.

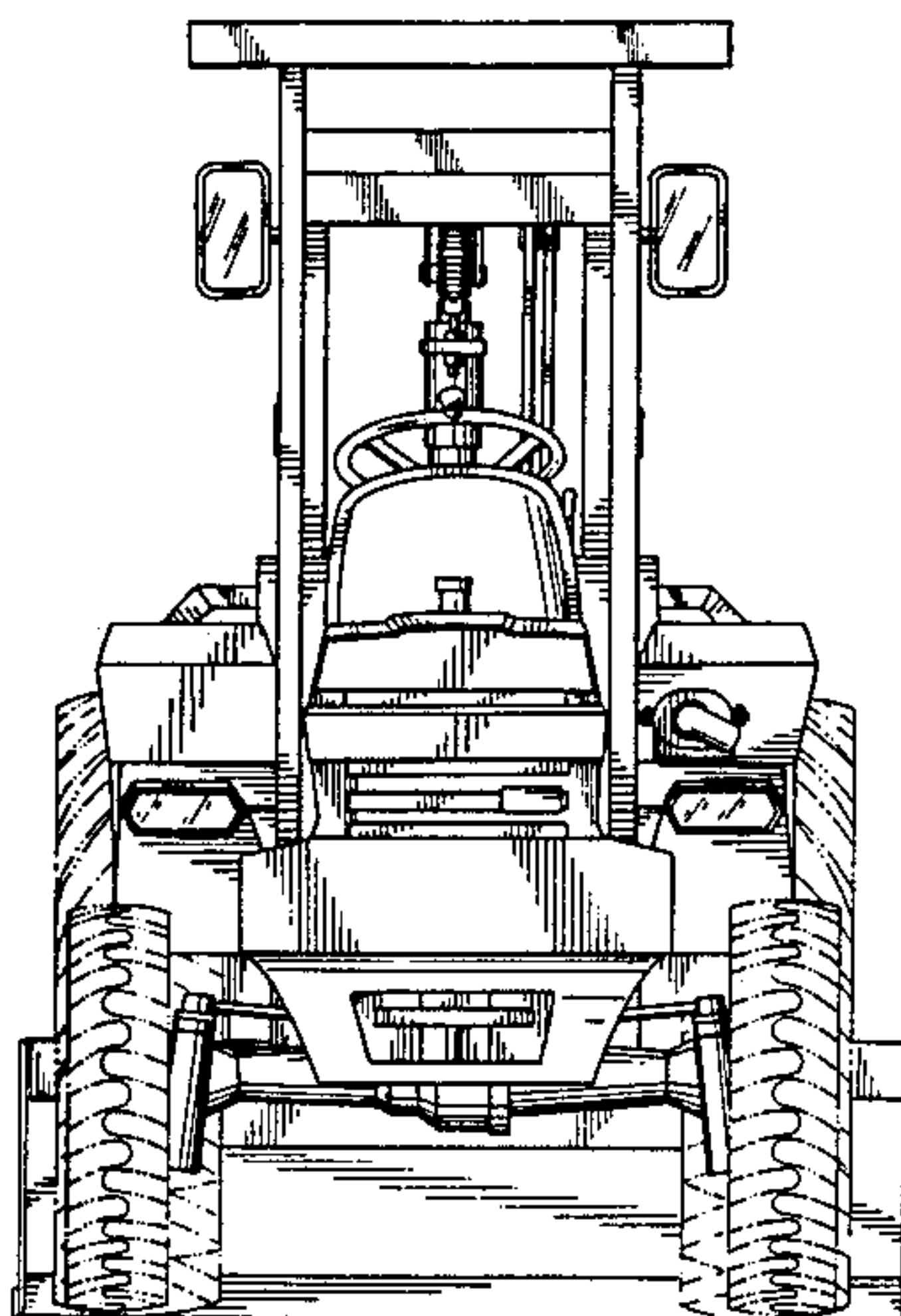
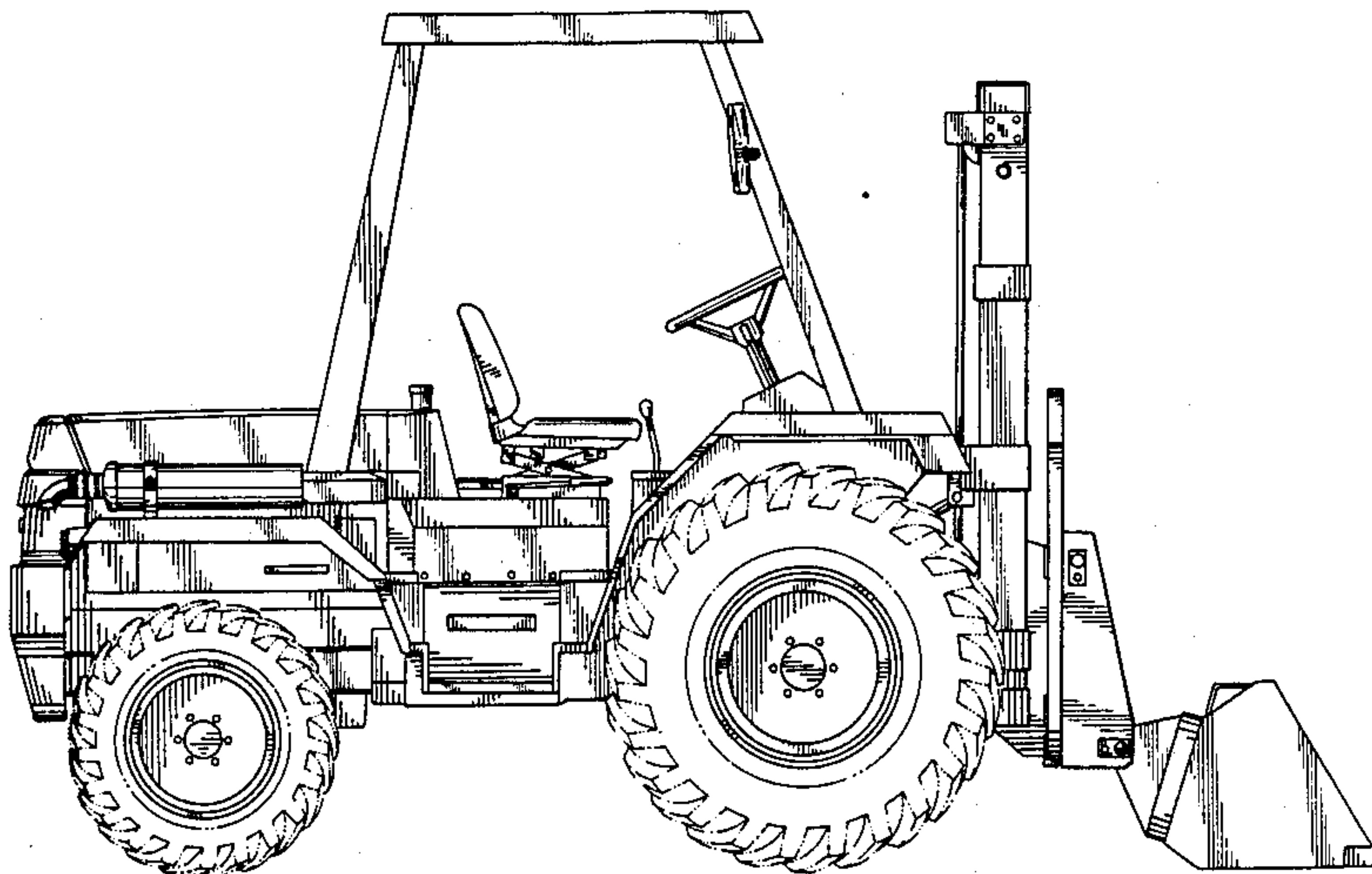

Fig. 1

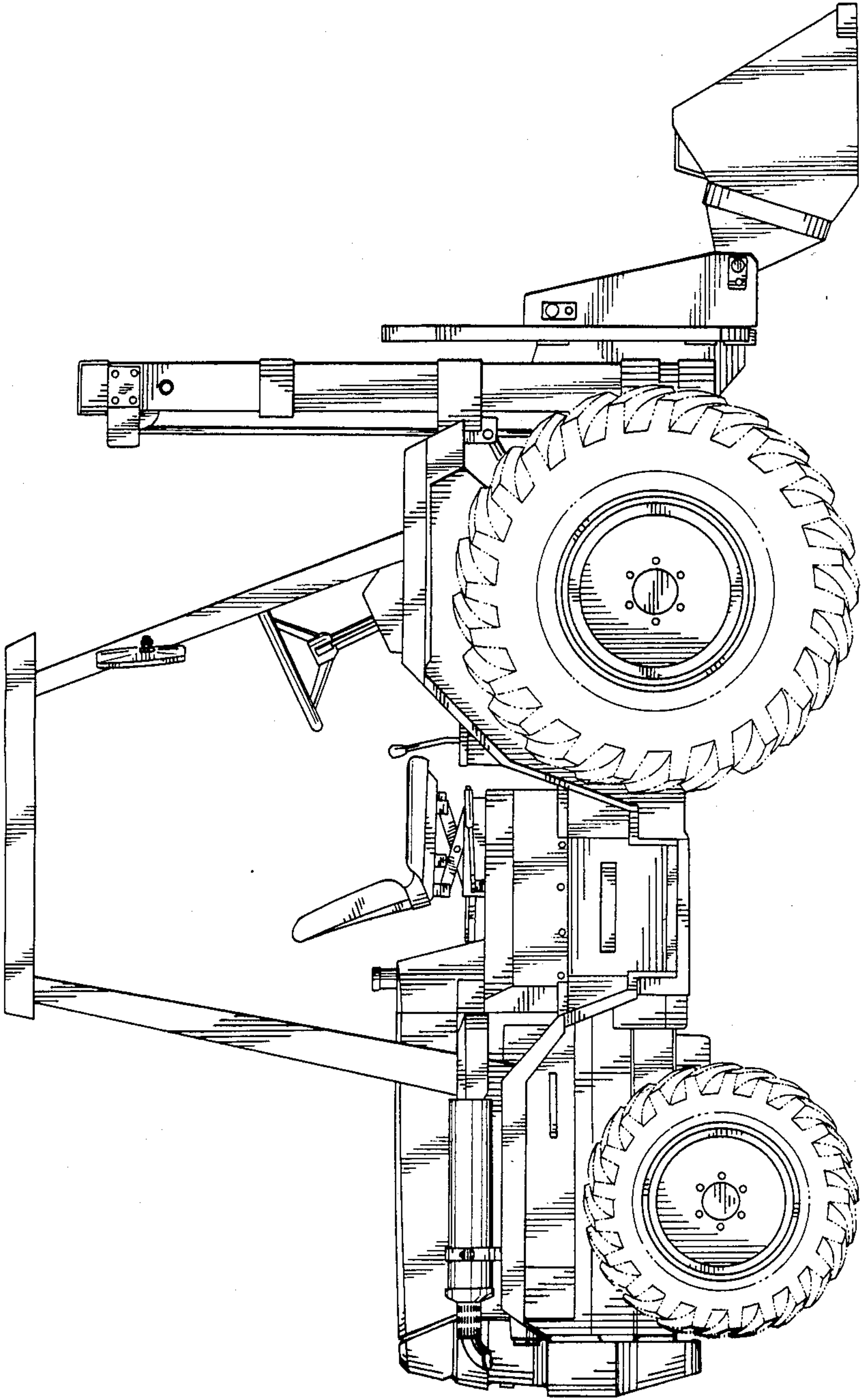

Fig. 2

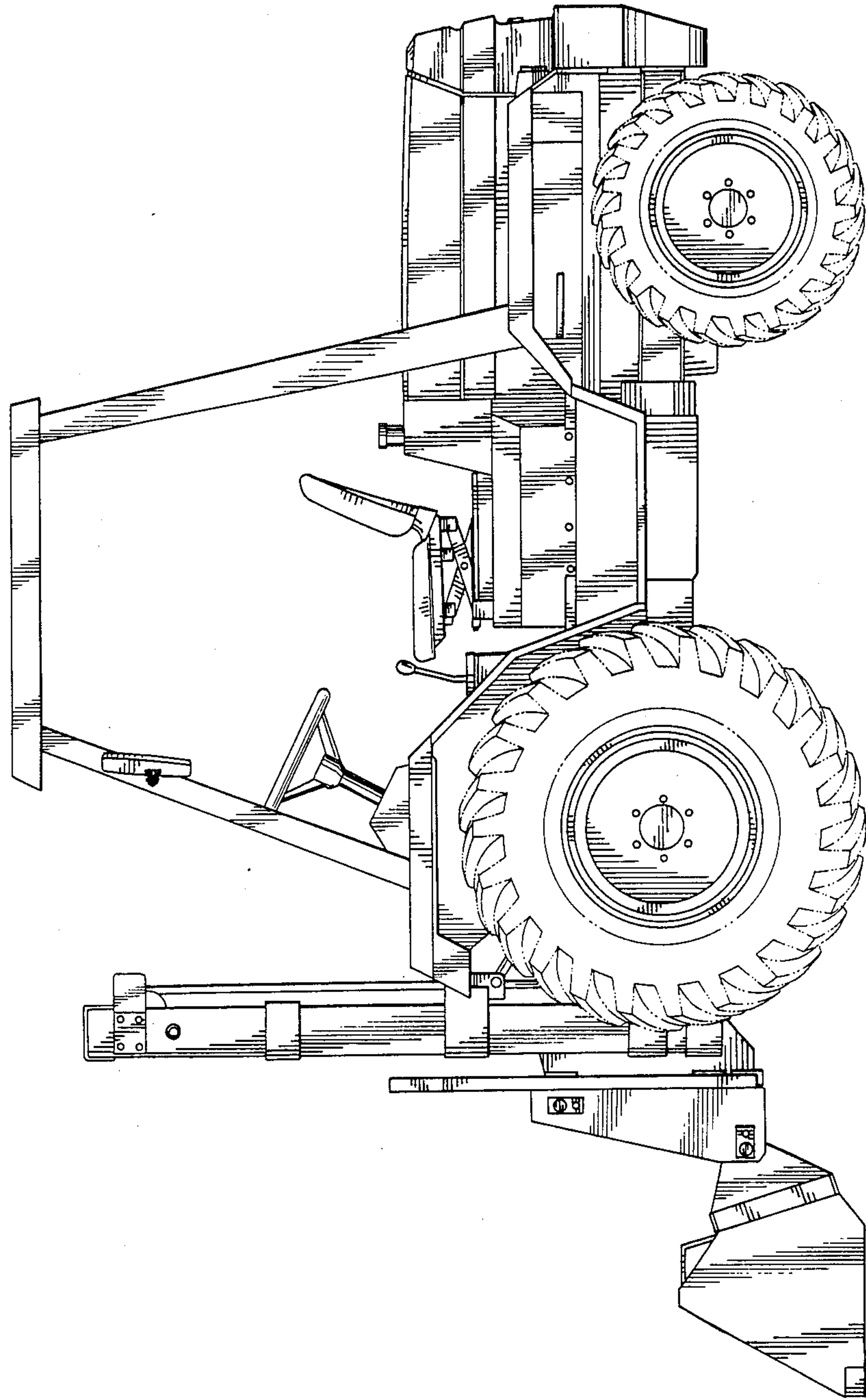

Fig. 3

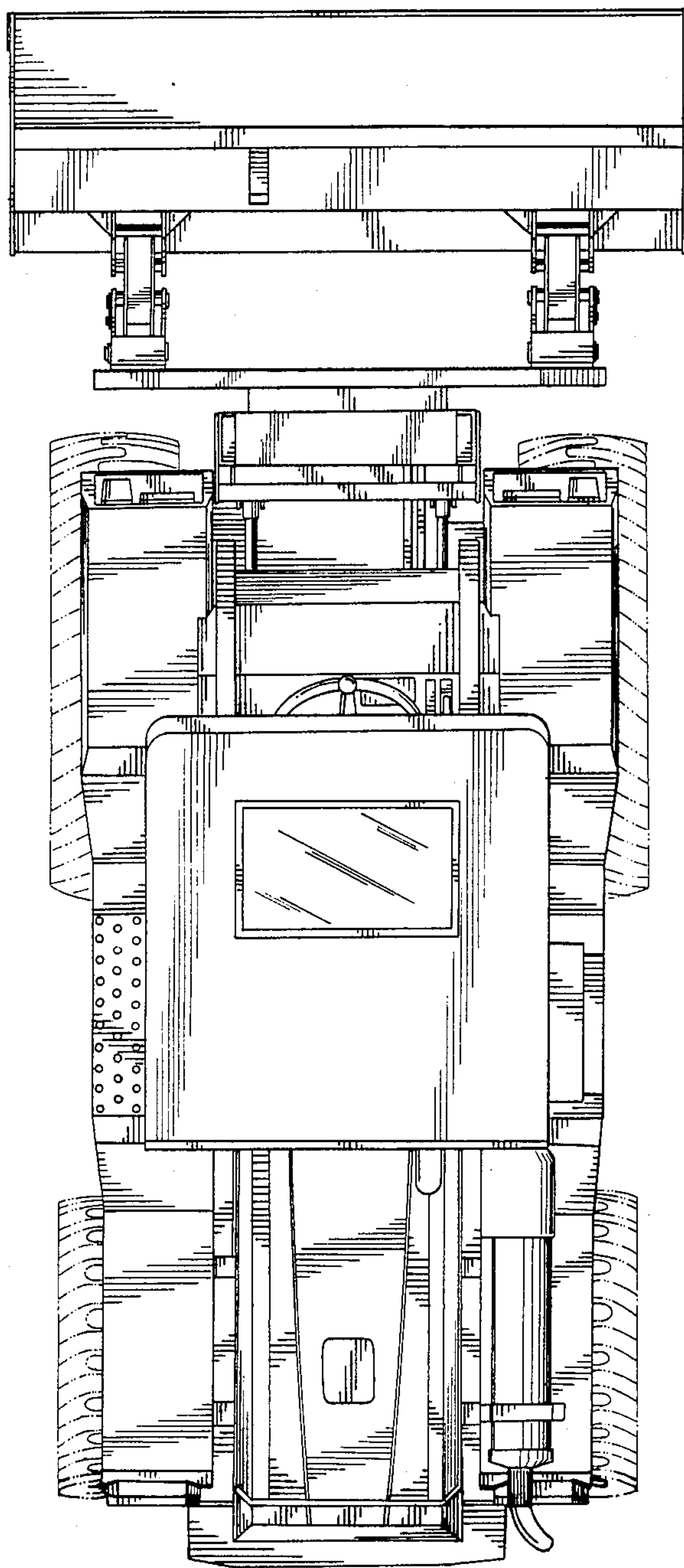

Fig.5

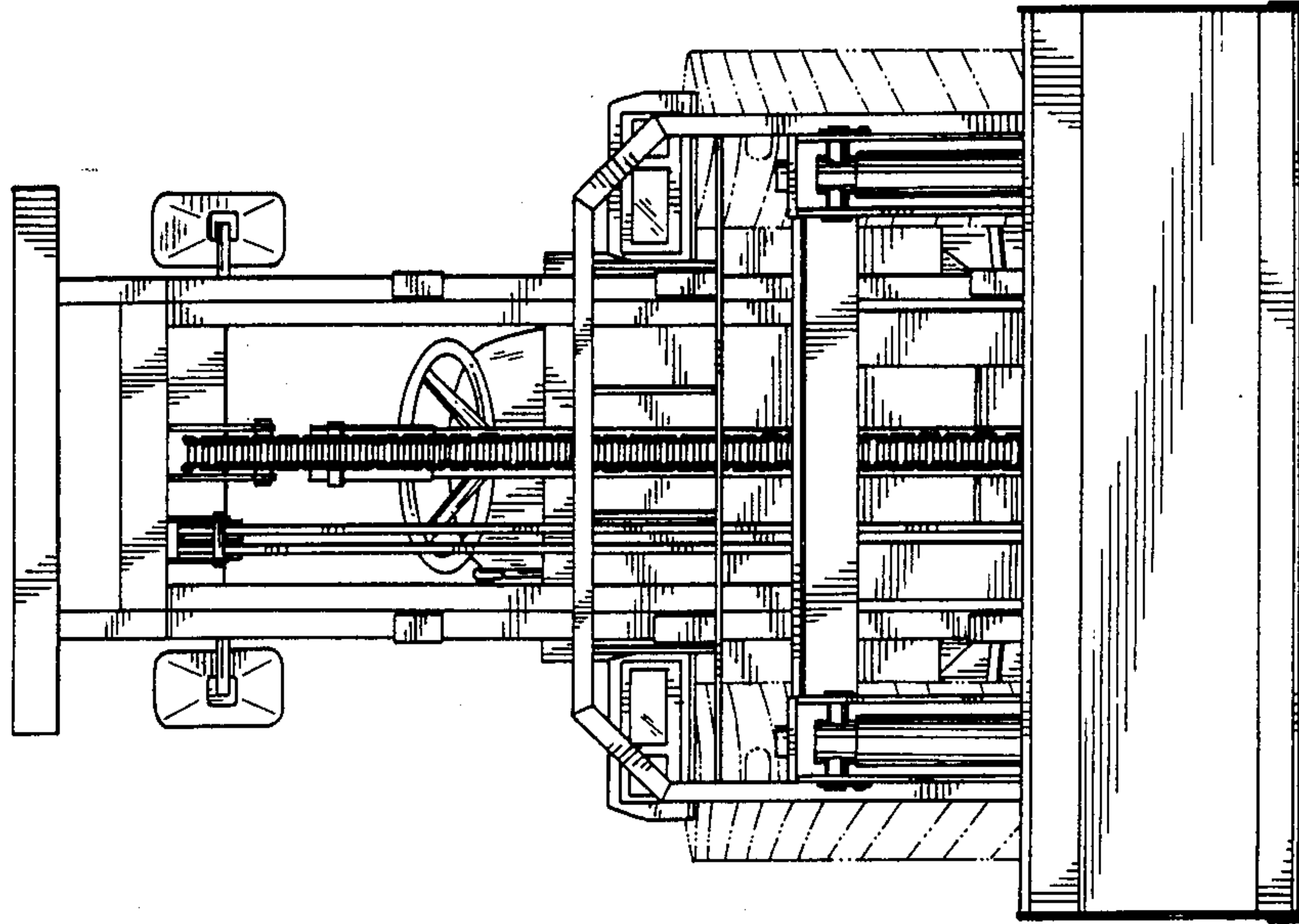

Fig.4

