

[54] SHOE UPPER

[75] Inventor: Edward Lussier, Hingham, Mass.

[73] Assignee: Reebok International Ltd., Canton, Mass.

[**] Term: 14 Years

[21] Appl. No.: 750,597

[22] Filed: Jul. 1, 1985

[52] U.S. Cl. D2/314; D2/310

[58] Field of Search D2/309-311, D2/312, 320, 314; 36/113-115, 129, 83-84, 50, 128

[56] References Cited

U.S. PATENT DOCUMENTS

- D. 198,157 5/1964 Poss D2/311
- D. 258,548 3/1981 Famolare D2/309
- D. 287,301 12/1986 Tong D2/310 X
- 4,506,462 3/1985 Cavanaugh 36/129 X
- 4,620,376 11/1986 Talarico 36/114 X

FOREIGN PATENT DOCUMENTS

- 3415960 11/1984 Fed. Rep. of Germany 36/51

OTHER PUBLICATIONS

An advertisement Circa 1966 for the A100 Challenger, A50 Captain and A110 Perfect Spiked Track shoe models.

J.W. Foster & Sons Ltd. 1935 Catalog "Foster's De Luxe".

Footwear News, Jan. 7, 1985, p. 26 "Sweats bi ebe".

Primary Examiner—Nelson C. Holtje

Attorney, Agent, or Firm—Saidman, Sterne, Kessler & Goldstein

[57] CLAIM

The ornamental design for a shoe upper, as shown and described.

DESCRIPTION

FIG. 1 is a top plan view of a shoe upper showing my new design;

FIG. 2 is a left side elevational view thereof;

FIG. 3 is a right side elevational view thereof;

FIG. 4 is a front elevational view thereof; and

FIG. 5 is a rear elevational view thereof, the broken line showing of a sole being environmental only, and forms no part of the claimed design.

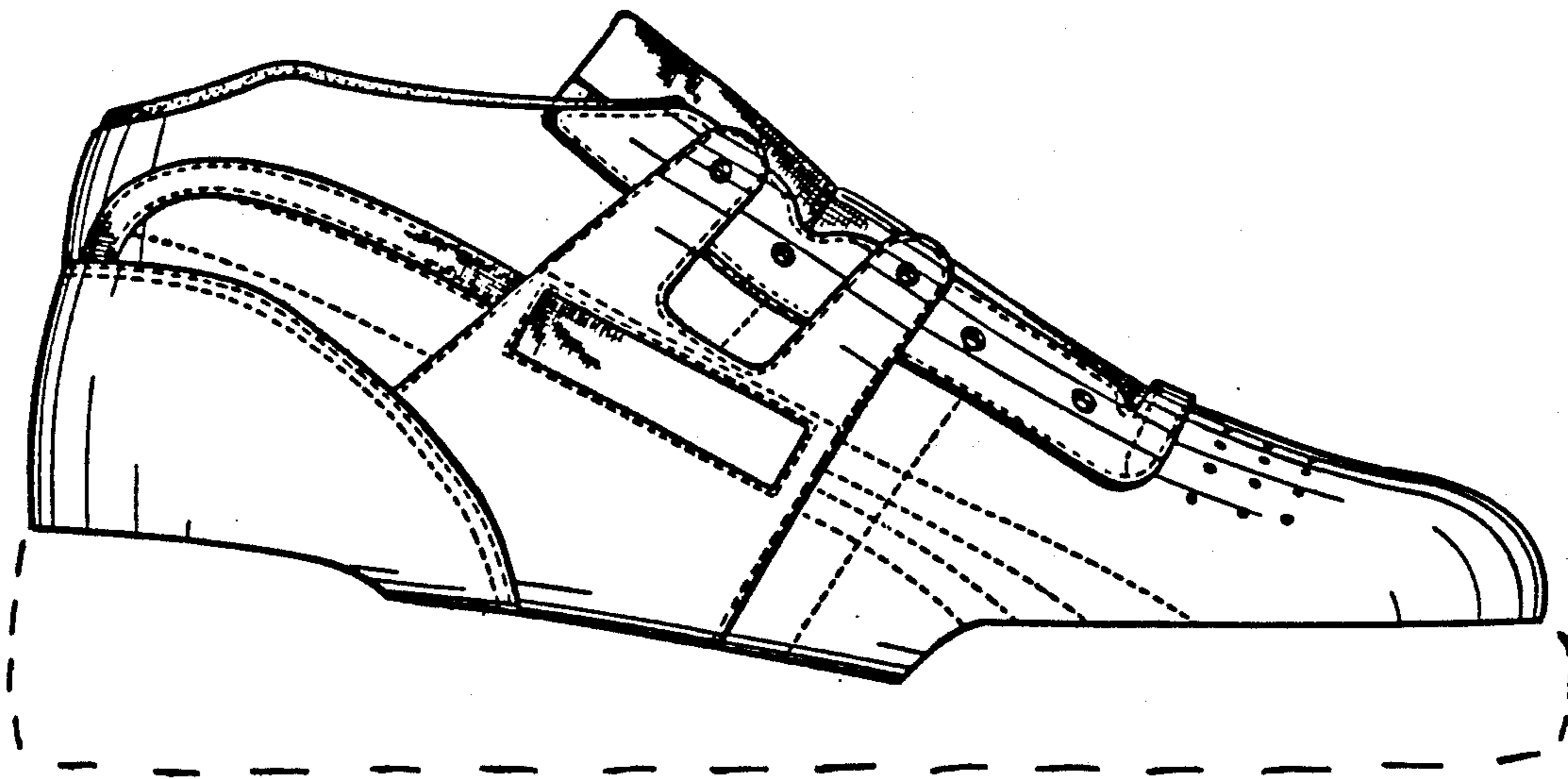

Fig. 1

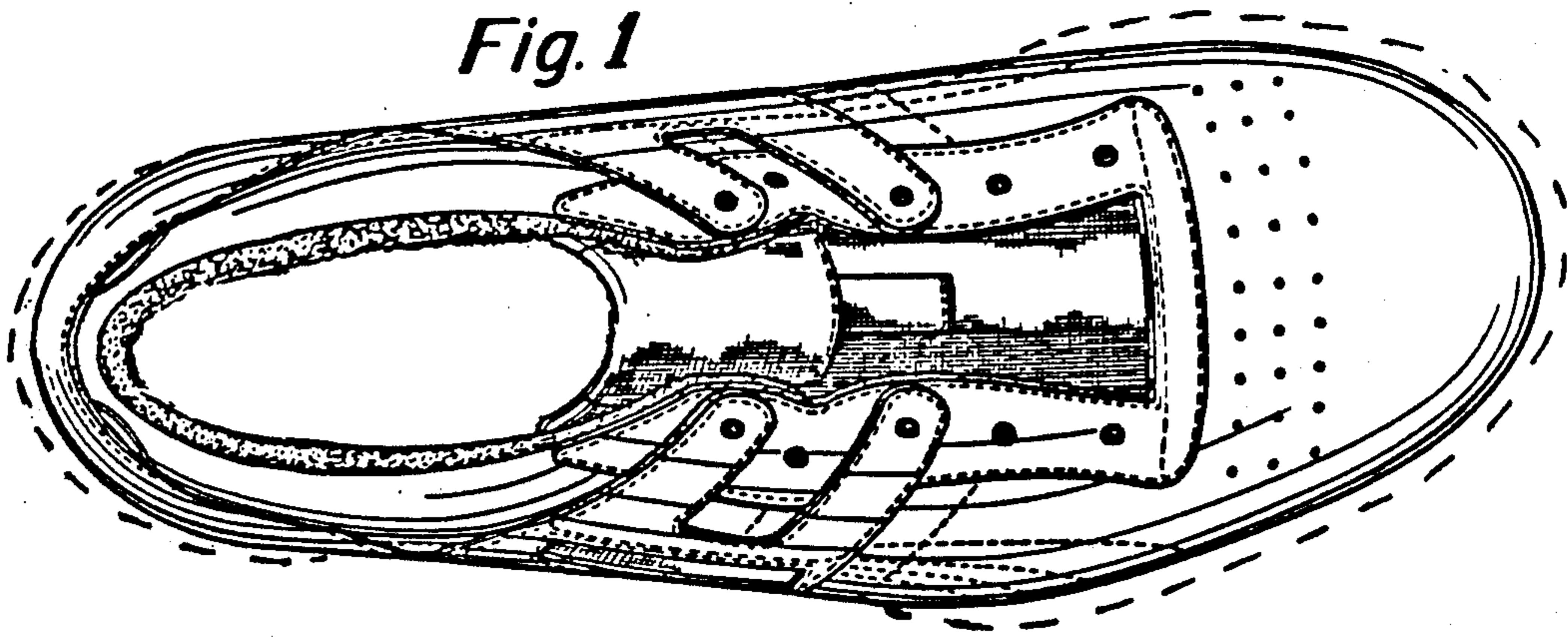

Fig. 2

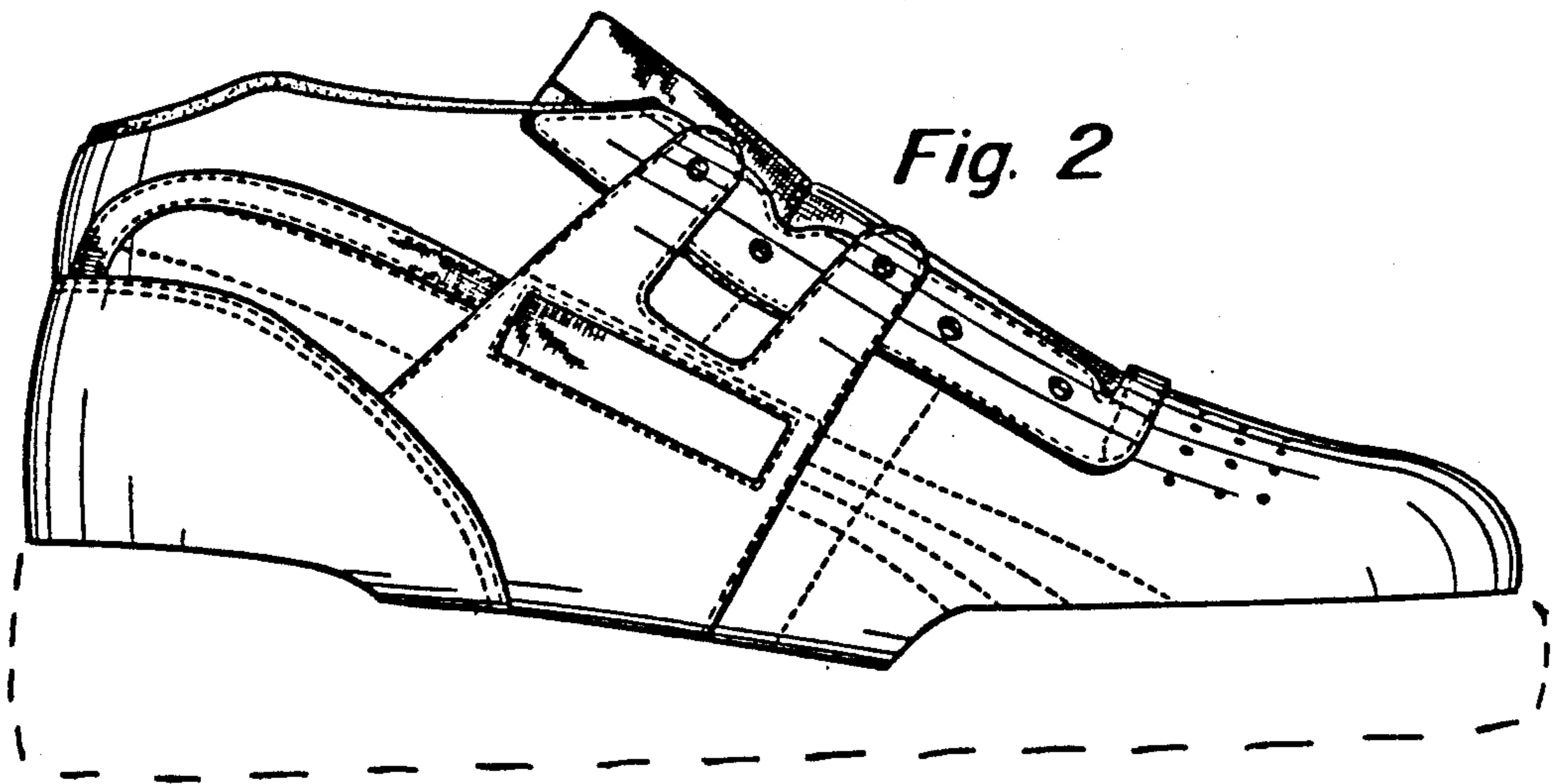
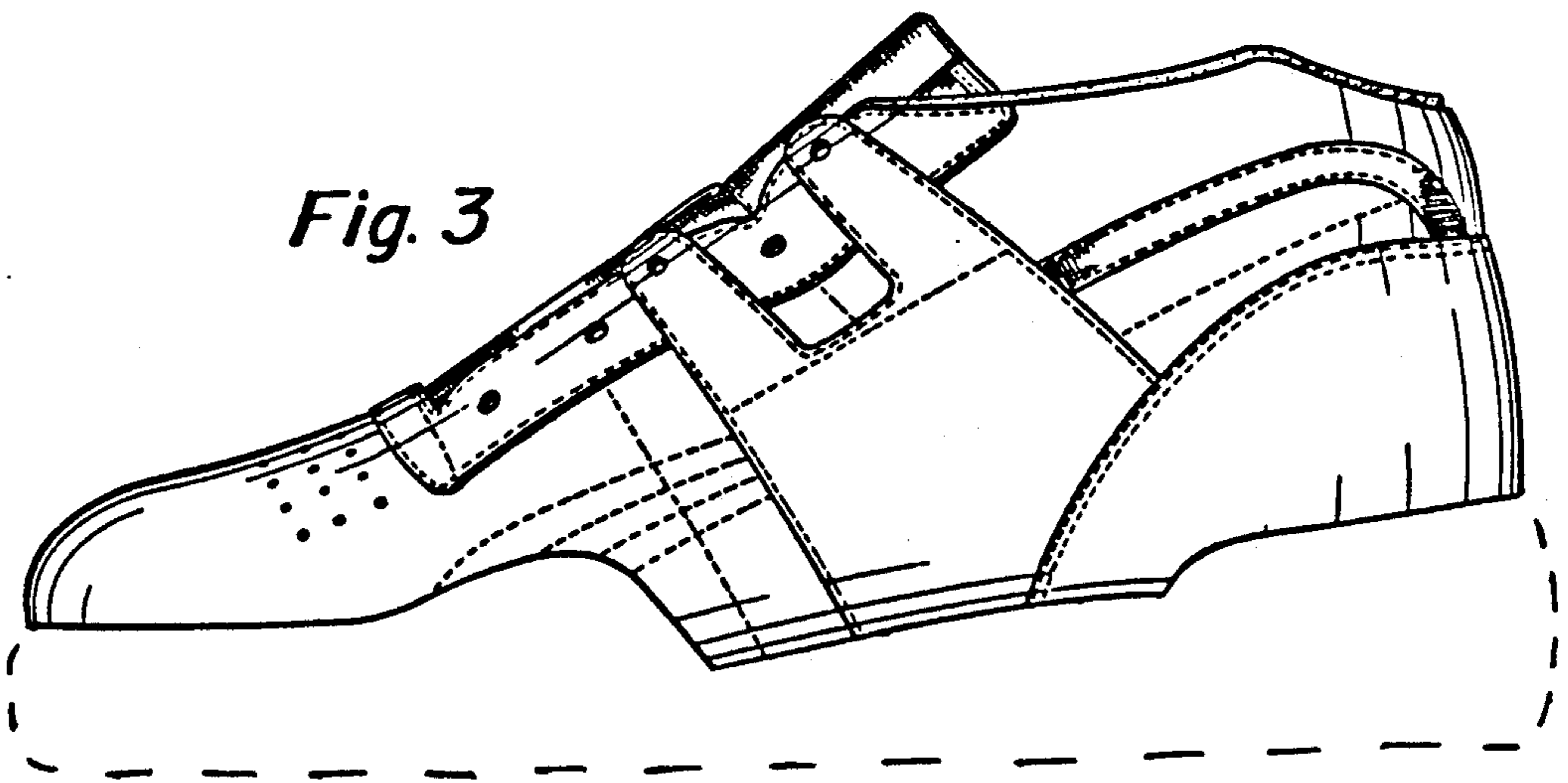

Fig. 3



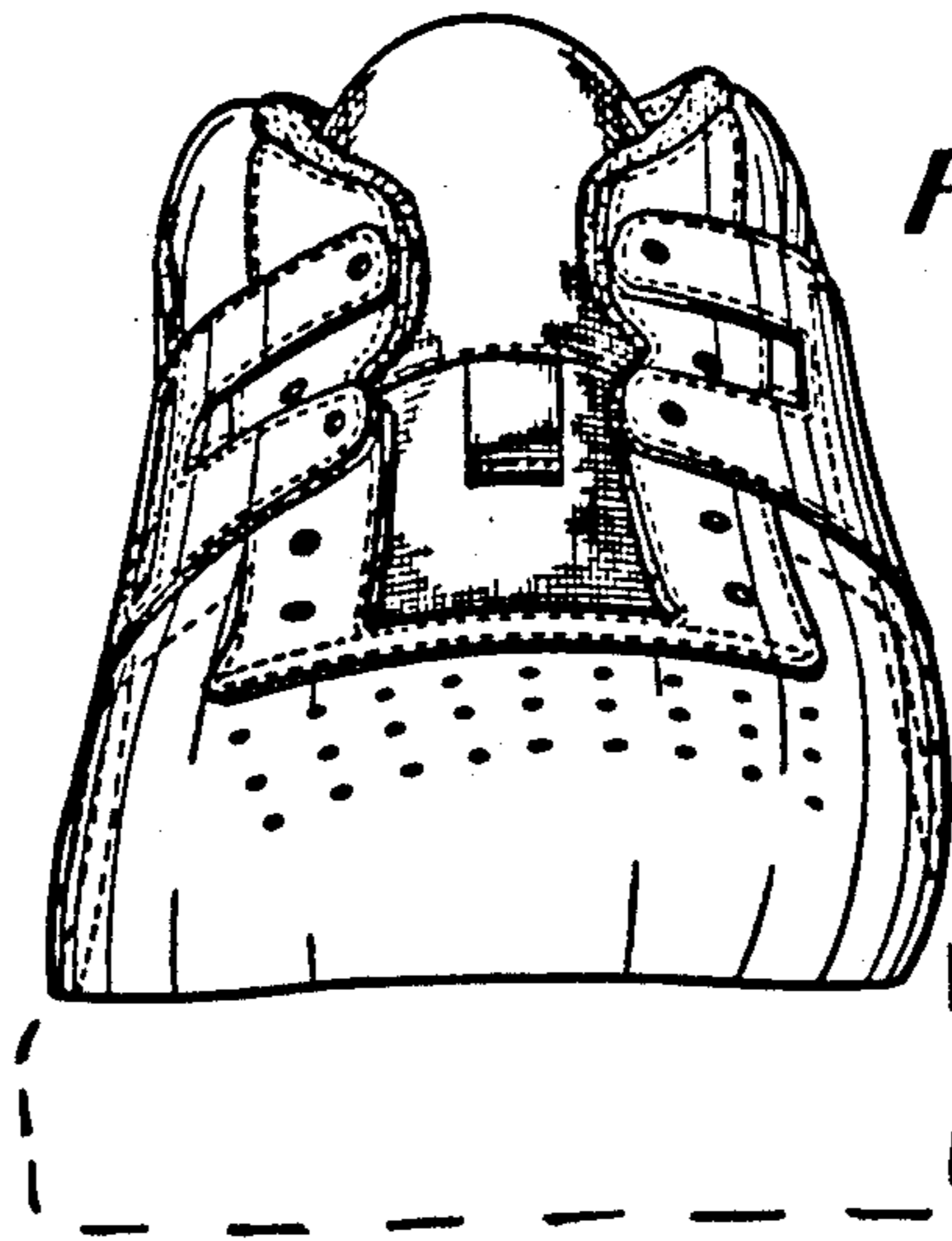

Fig. 4

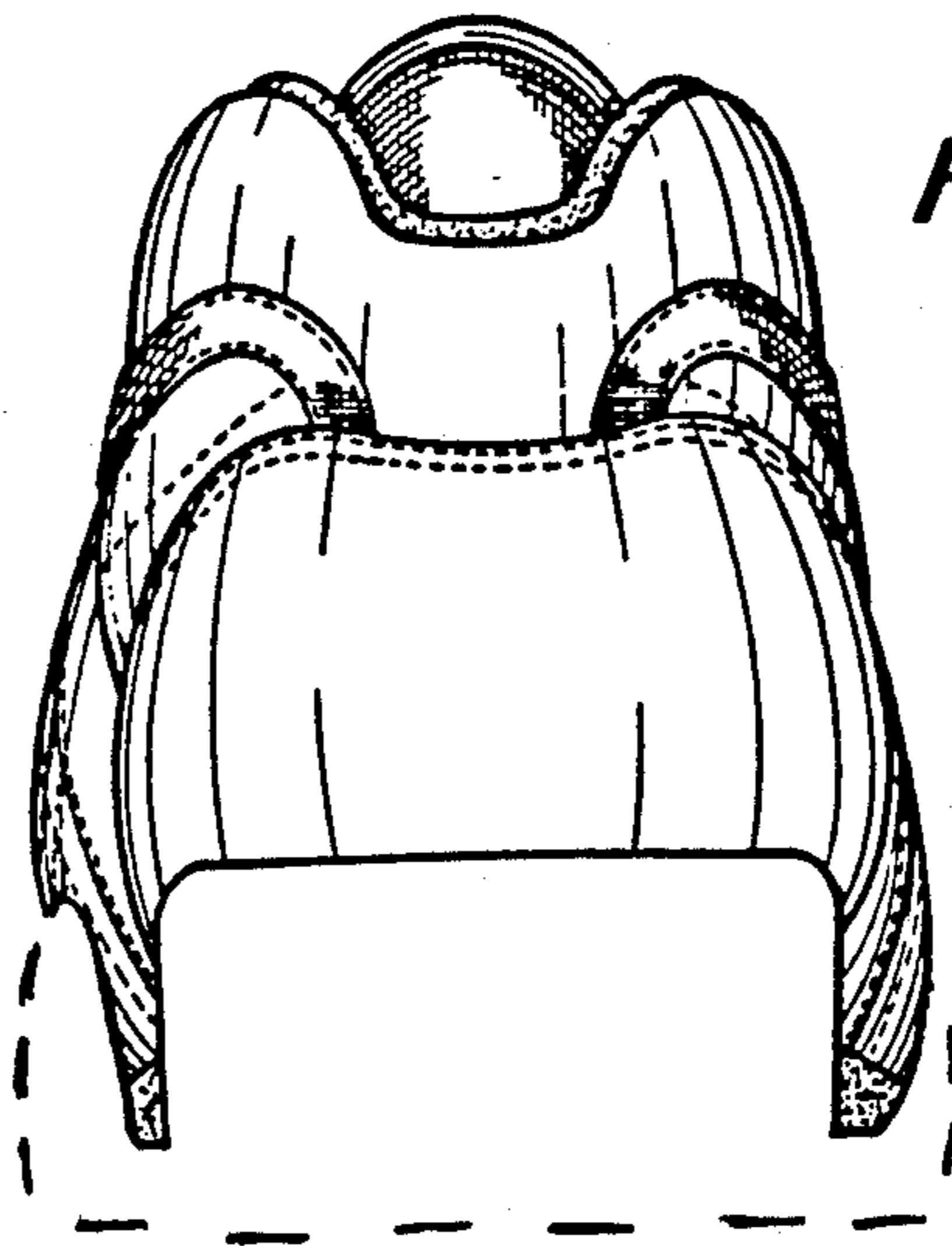

Fig. 5