

[54] **COMBINED VEHICLE SIDE RAIL, STEP AND SPLASH GUARD**

[76] **Inventor: Rick Huff, c/o Future Fiberglass, Box E, Lapaz, Ind. 46537**

[**] **Term: 14 Years**

[21] **Appl. No.: 947,559**

[22] **Filed: Dec. 29, 1986**

[52] **U.S. Cl. D12/203**

[58] **Field of Search D12/203; 280/163, 164 R, 280/154.5 R**

[56] **References Cited**

U.S. PATENT DOCUMENTS

- D. 258,128 2/1981 Baker D12/203
- D. 262,283 12/1981 Borick D12/203
- D. 289,891 5/1987 Bielby D12/203
- D. 292,904 11/1987 Bielby D12/203

Primary Examiner—James M. Gandy
Attorney, Agent, or Firm—James D. Hall

[57] **CLAIM**

The ornamental design for a combined vehicle side rail, step and splash guard, as shown and described.

DESCRIPTION

FIG. 1 is a perspective view of the top, front and one end of a combined vehicle siderail, step and splash guard showing my new design;
FIG. 2 is a front elevation view thereof;
FIG. 3 is a top plan view thereof;
FIG. 4 is an end elevation view thereof, the opposite end being a mirror image of that shown;
FIG. 5 is a perspective view of the top, front and one end of a combined vehicle side rail, step and splash guard showing a second embodiment of my new design, it being understood that the opposite end is a mirror image of the end shown; and
FIG. 6 is a top plan view of FIG. 5.
The broken line showing of fragmentary portions of a vehicle in FIGS. 1, 2 and 5 of the drawing is for illustrative purposes only and forms no part of the claimed design.

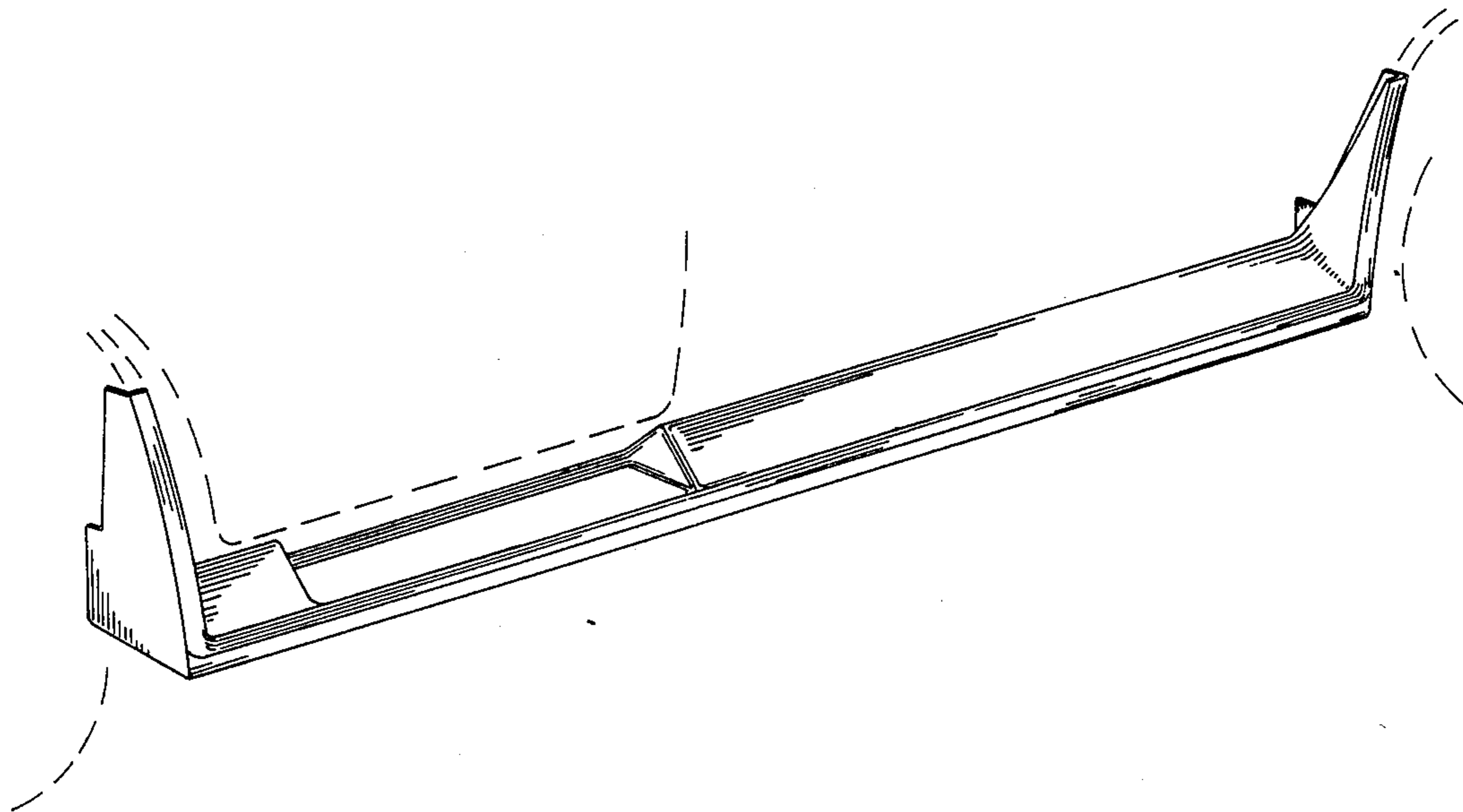

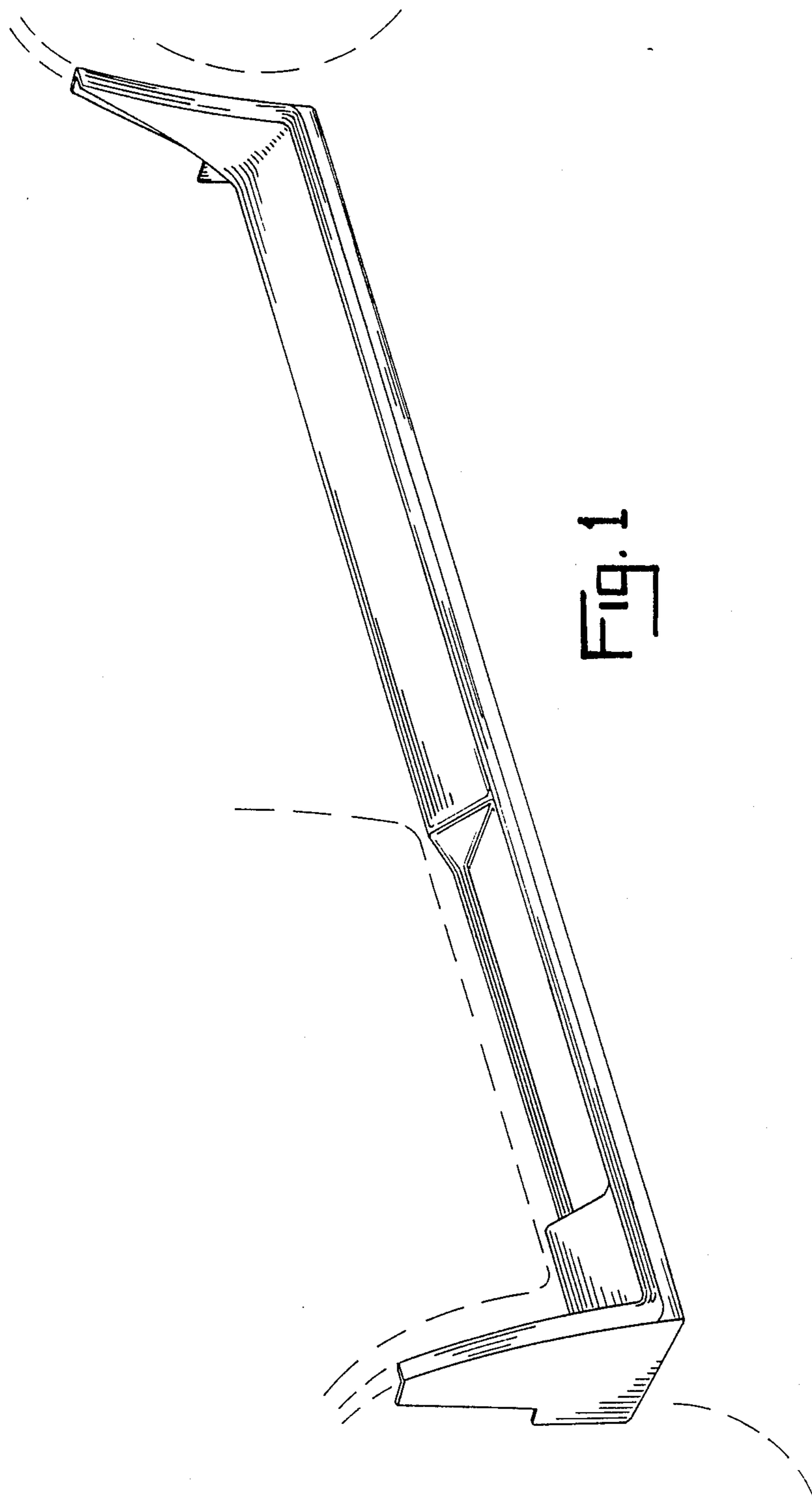

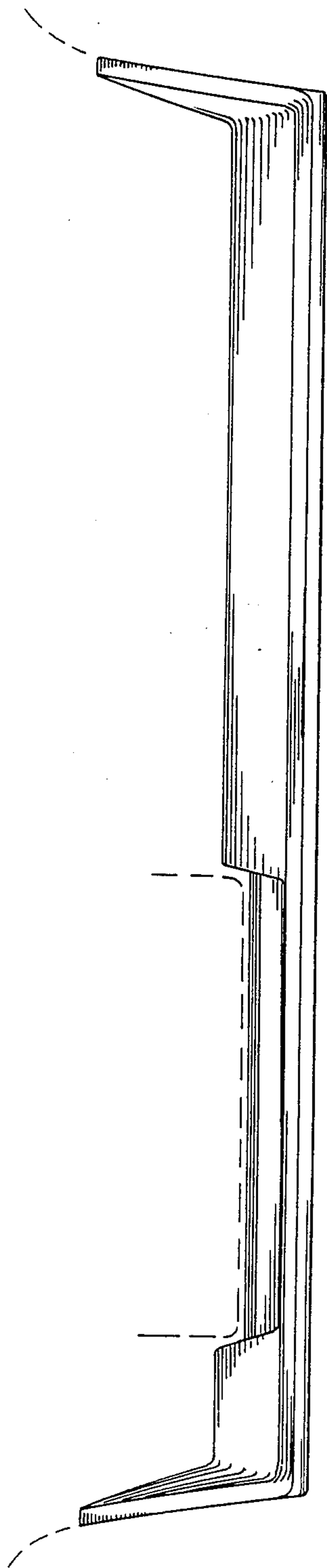

FIG. 2

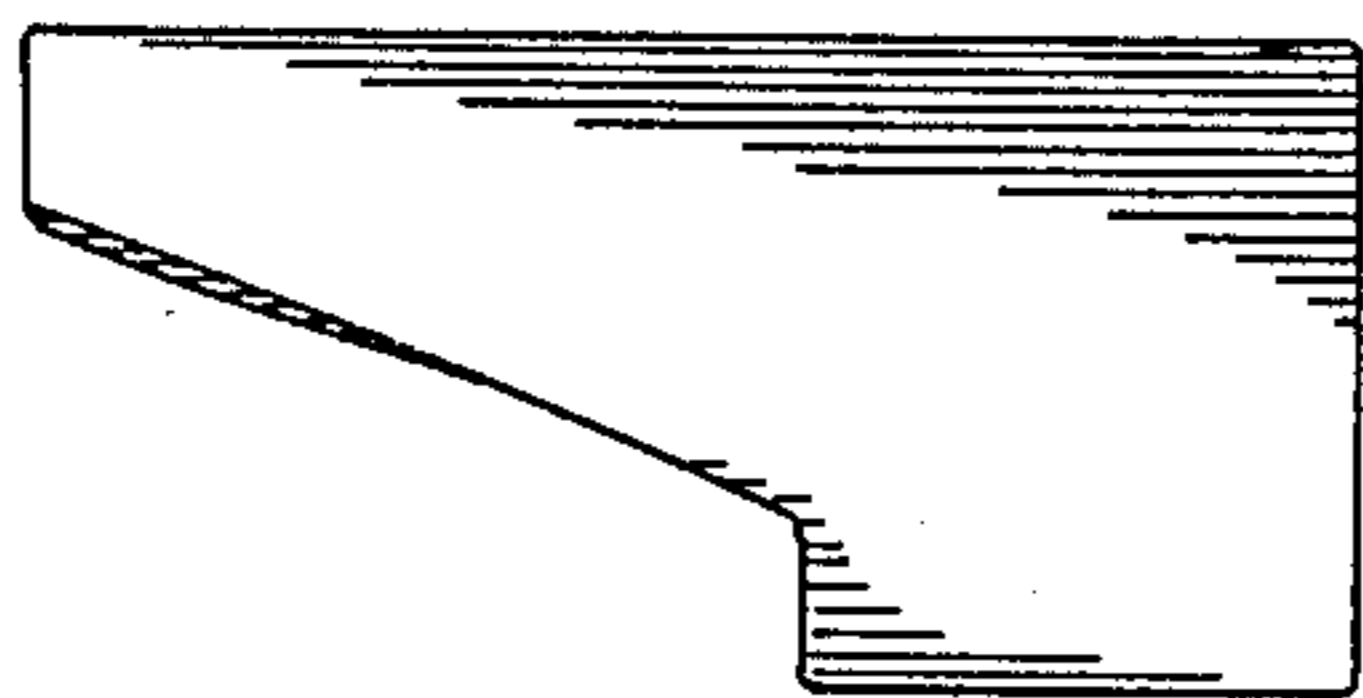

FIG. 4

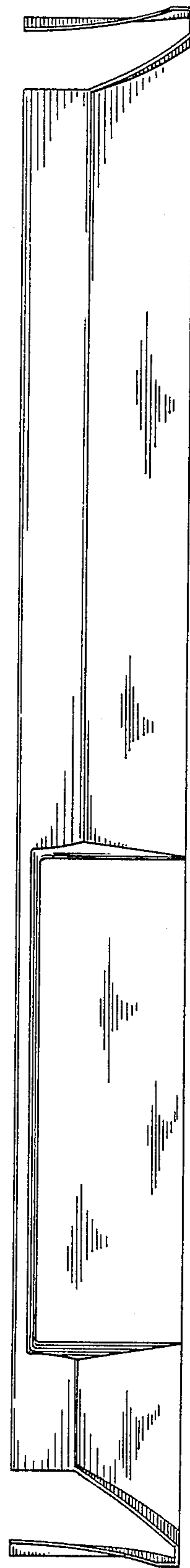

FIG. 3

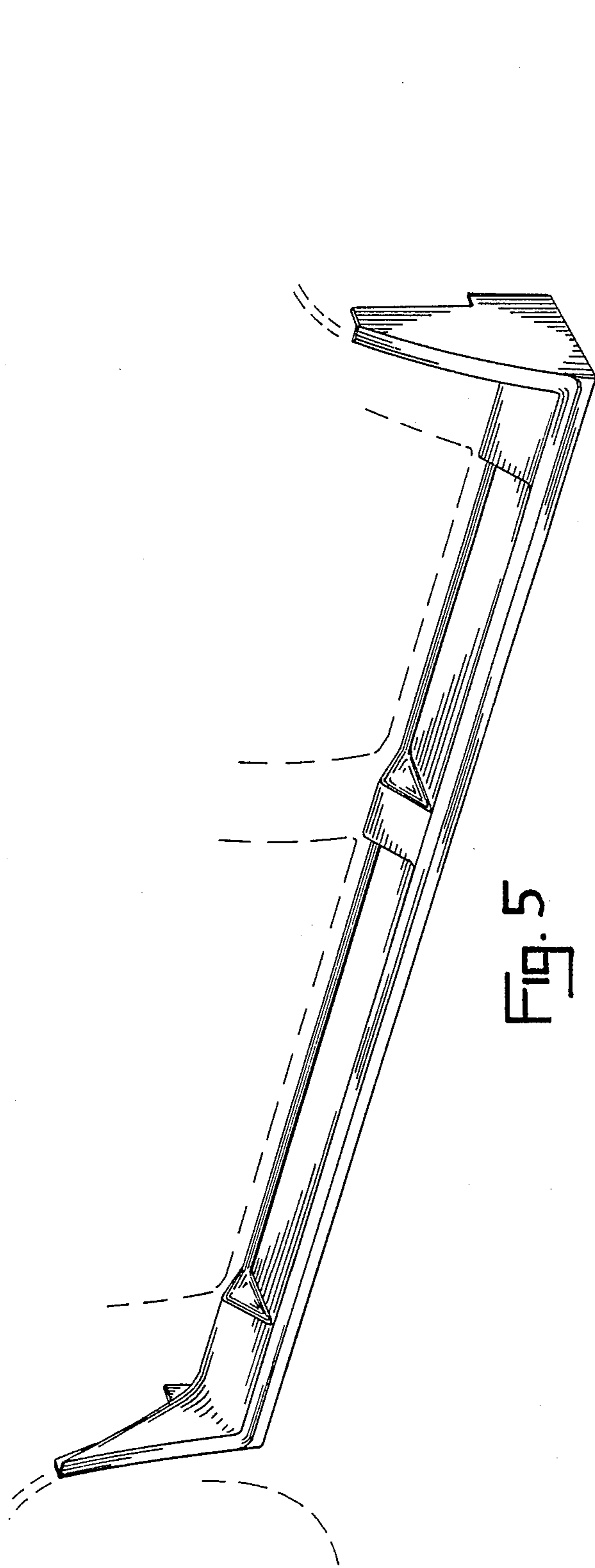

FIG. 5

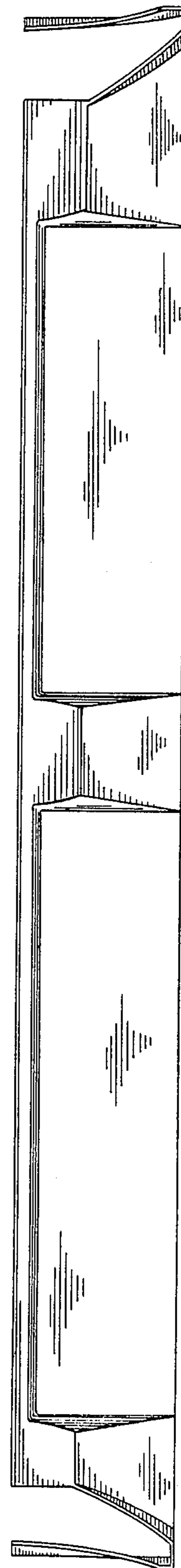

FIG. 6