

[54] PIVOTABLE MOBILE HOME VEHICLE STAIR RAIL

[76] Inventor: Glen McElvania, R.R., Alden, Iowa 50006

[\*\*] Term: 14 Years

[21] Appl. No.: 805,052

[22] Filed: Nov. 12, 1985

[52] U.S. Cl. .... D25/38; D12/106

[58] Field of Search ..... D25/38, 116, 154, 155; D12/106; 256/21, 22

[56] References Cited

U.S. PATENT DOCUMENTS

D. 193,892 10/1962 Clanton ..... D25/116

D. 243,093 1/1977 Reynolds ..... D12/106

Primary Examiner—James M. Gandy

Attorney, Agent, or Firm—Kent A. Herink; G. Brian Pingel

[57] CLAIM

The ornamental design for a pivotable mobile home vehicle stair rail, as shown and described.

DESCRIPTION

FIG. 1 is a perspective view of a pivotable mobile home vehicle stair rail showing my new design;

FIG. 2 is a rear elevation view;

FIG. 3 is a front elevation view;

FIG. 4 is a top plan view;

FIG. 5 is a bottom plan view;

FIG. 6 is a side elevation view;

FIG. 7 is a perspective view thereof on a greatly reduced scale in operative condition attached to a mobile home vehicle which is fragmentarily shown in broken lines for illustrative purposes only; and

FIG. 8 is a perspective view similar to FIG. 7 but with the stair rail in stored and transport condition.

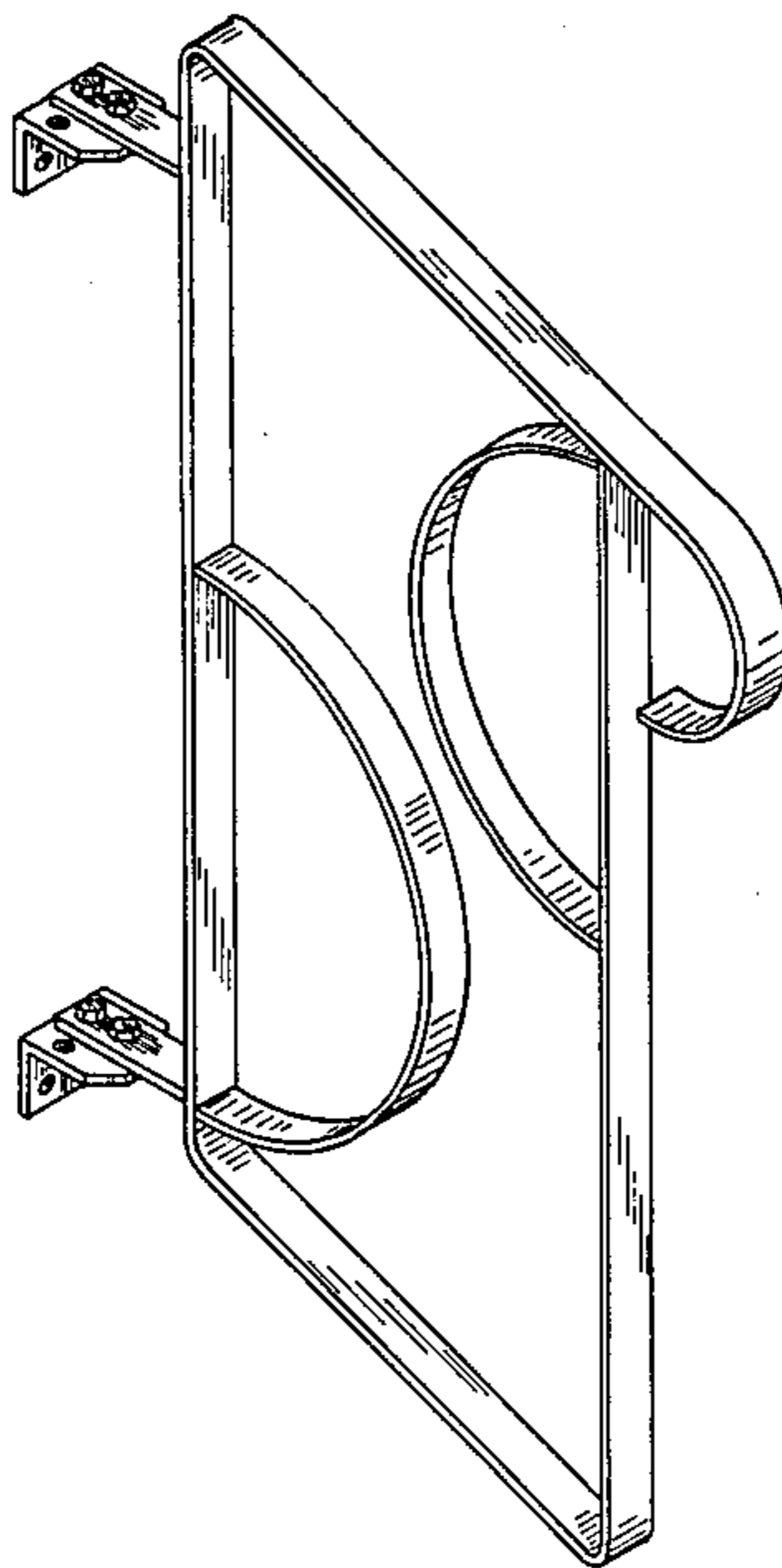

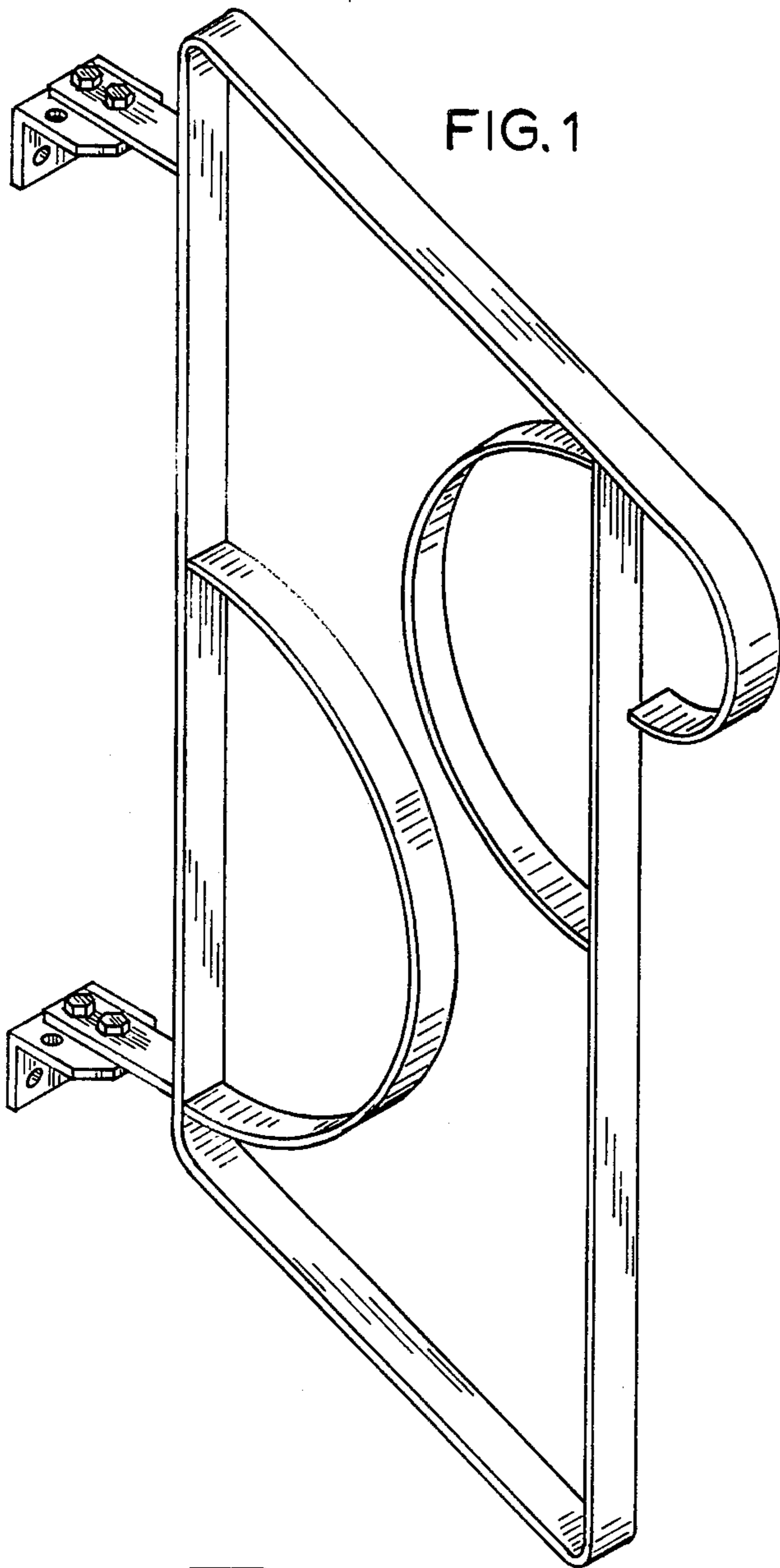

FIG. 2

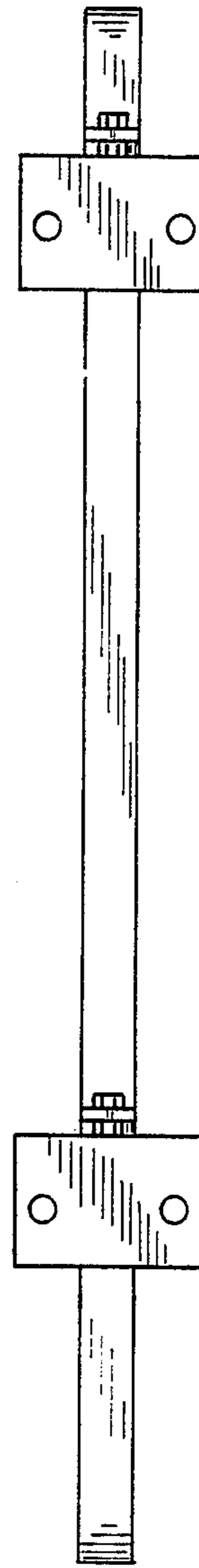

FIG. 3

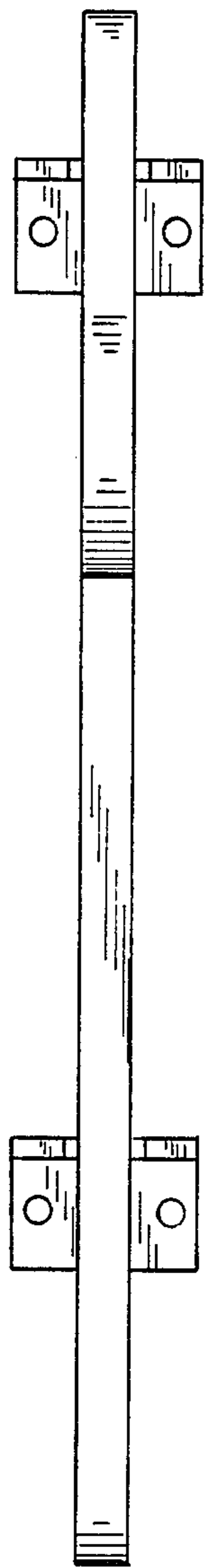

FIG. 4

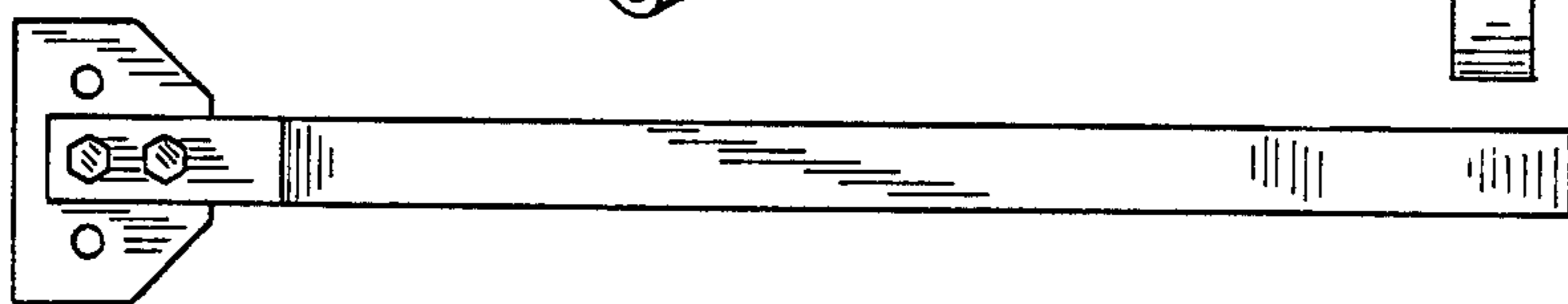
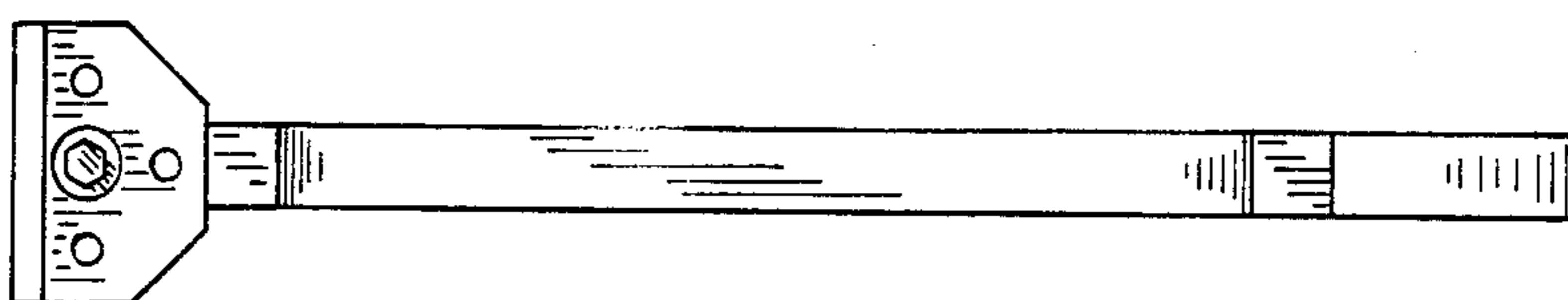

FIG. 5



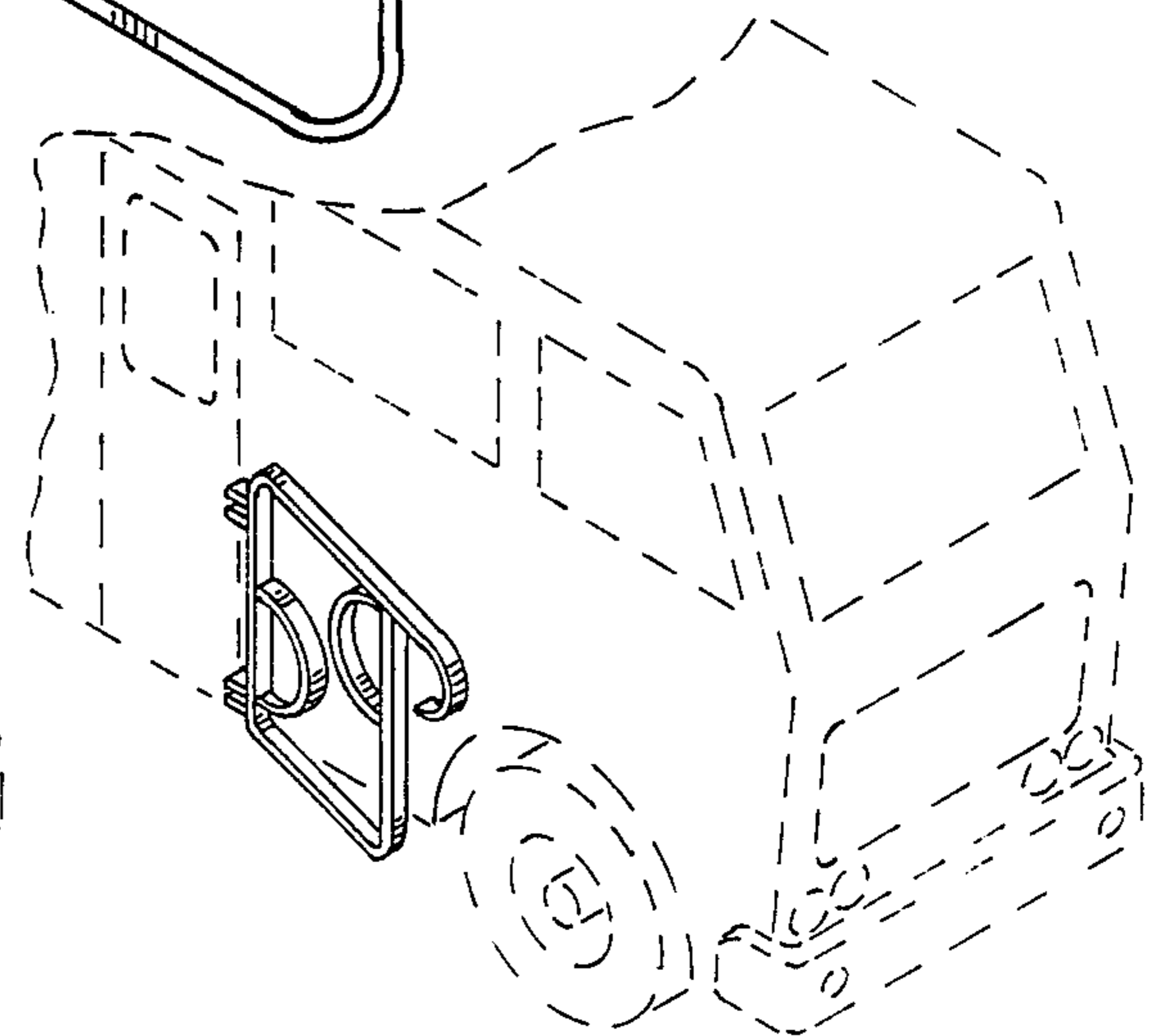
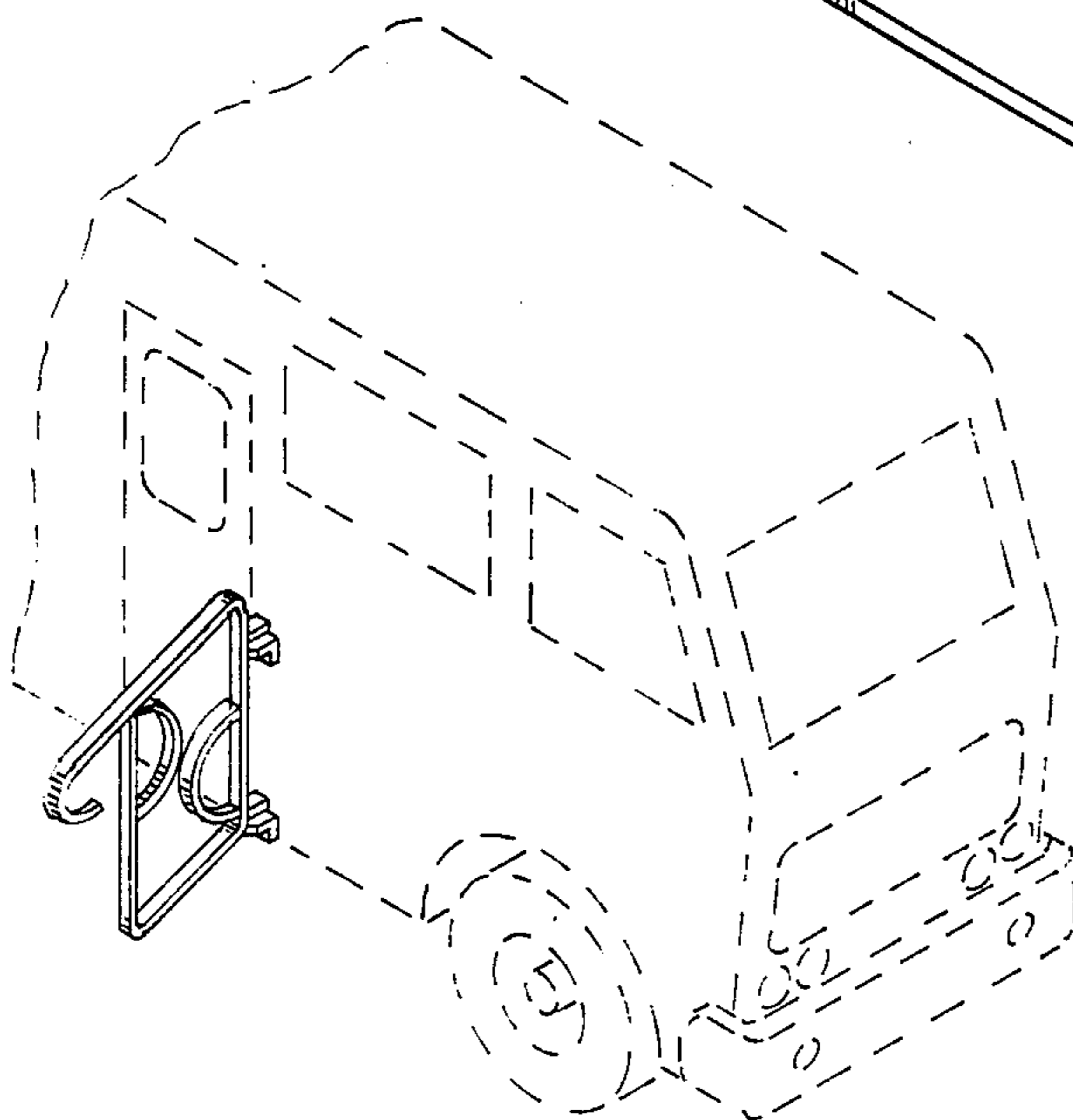
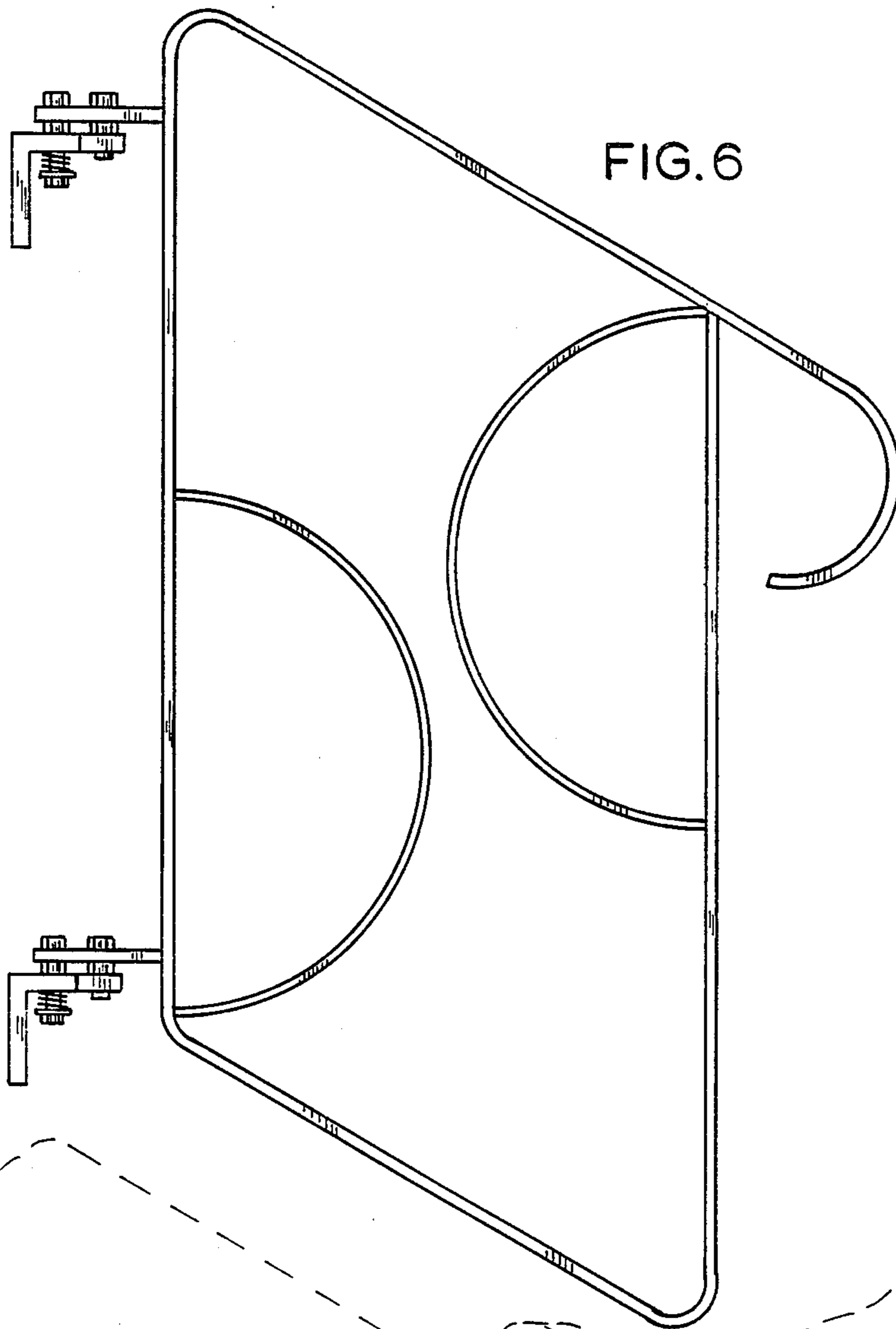

FIG. 7

FIG. 8