

United States Patent [19]

Kawamura

[11] Patent Number: Des. 297,051

[45] Date of Patent: ** Aug. 2, 1988

[54] ELECTRONIC SPHYGMOMANOMETER

[75] Inventor: Masaki Kawamura, Osaka, Japan

[73] Assignee: Sharp Corporation, Osaka, Japan

[**] Term: 14 Years

[21] Appl. No.: 774,754

[22] Filed: Sep. 11, 1985

[30] Foreign Application Priority Data

Mar. 14, 1985 [JP] Japan 60-10410

[52] U.S. Cl. D24/21; D24/17

[58] Field of Search D24/17, 21;
128/677-690; D10/75; D18/7, 2; D19/60;
D21/13; D14/115

[56] References Cited

U.S. PATENT DOCUMENTS

D. 258,655 3/1981 Levy D18/7

D. 266,935 11/1982 Del Principe et al. D18/7 X

D. 277,133 1/1985 Houlihan D24/17

D. 285,965 9/1986 Nishibori et al. D24/21

D. 286,437 10/1986 Nishibori D24/21

4,458,690 7/1984 O'Connor et al. 128/680

4,558,707 12/1985 Miyamae et al. 128/680

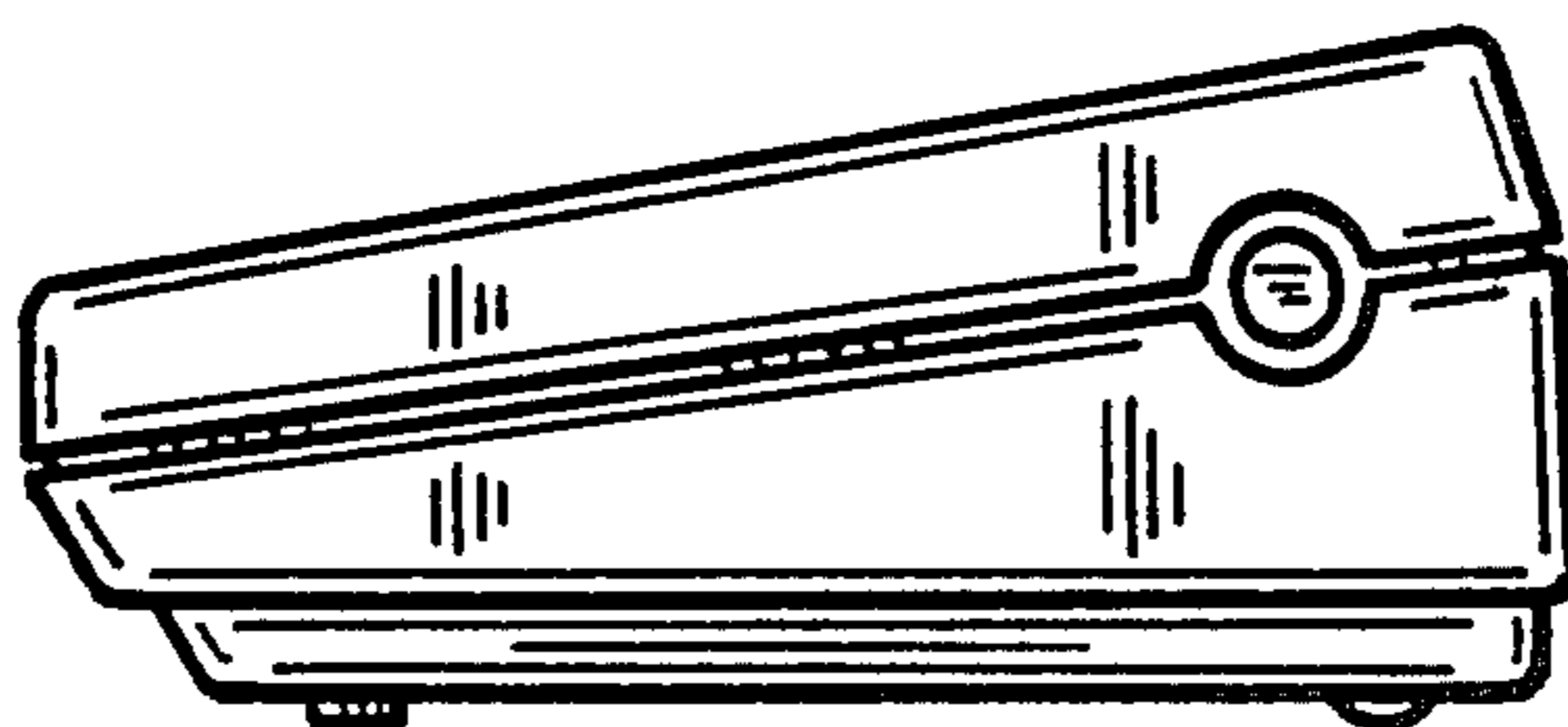
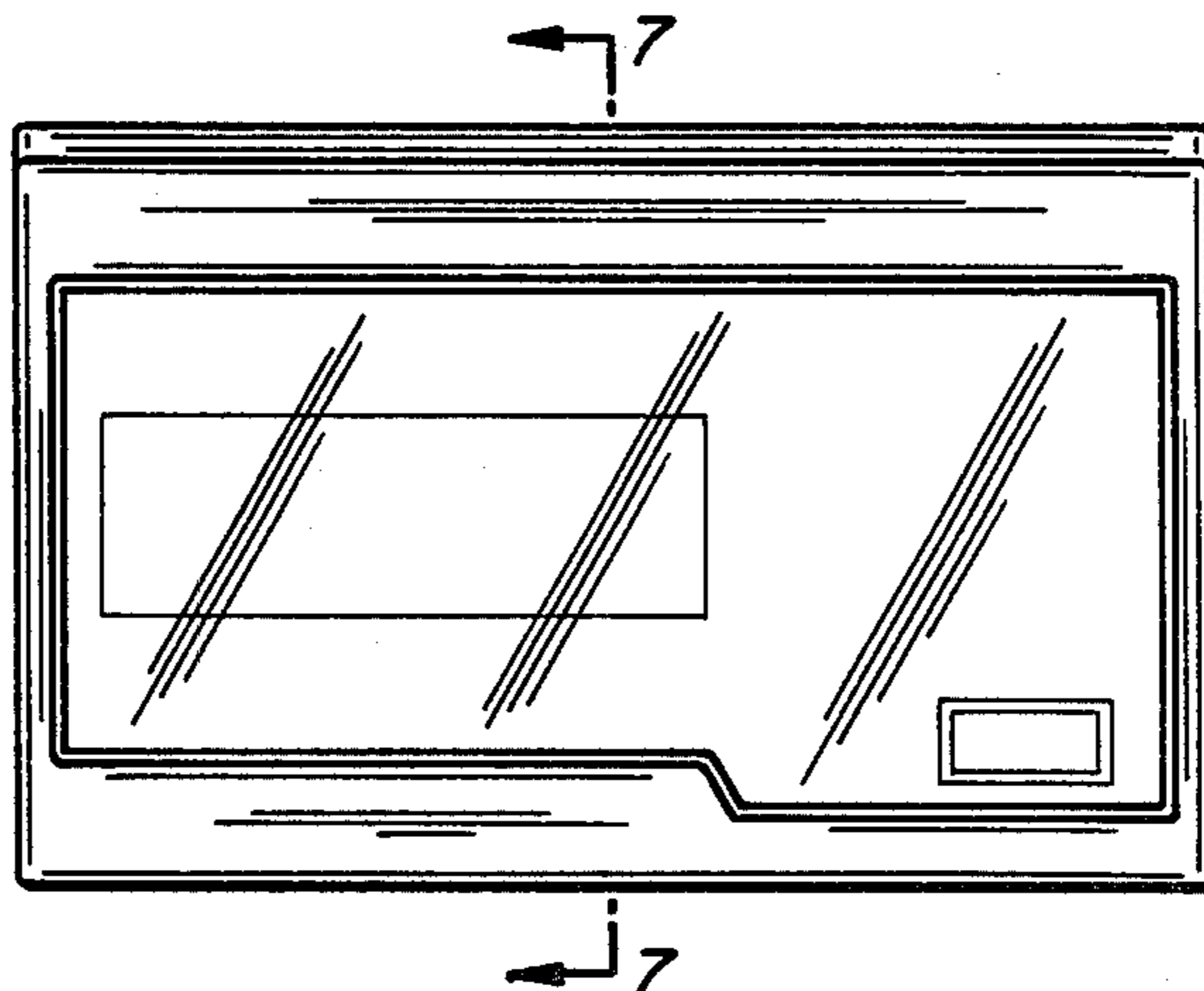
Primary Examiner—Wallace R. Burke
Assistant Examiner—Stella M. Reid
Attorney, Agent, or Firm—Flehr, Hohbach, Test,
Albritton & Herbert

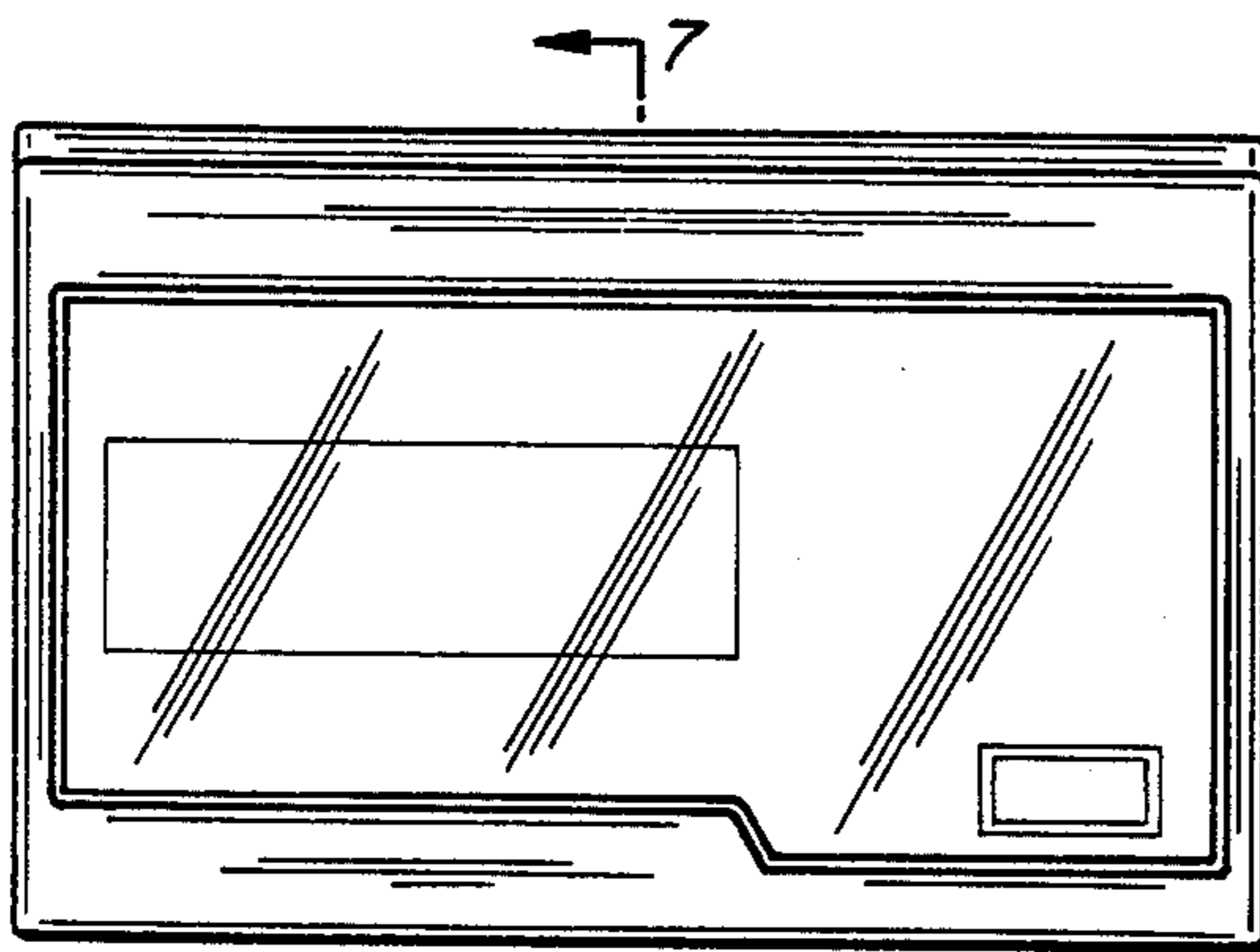
[57] CLAIM

The ornamental design for an electronic sphygmomanometer, as shown and described.

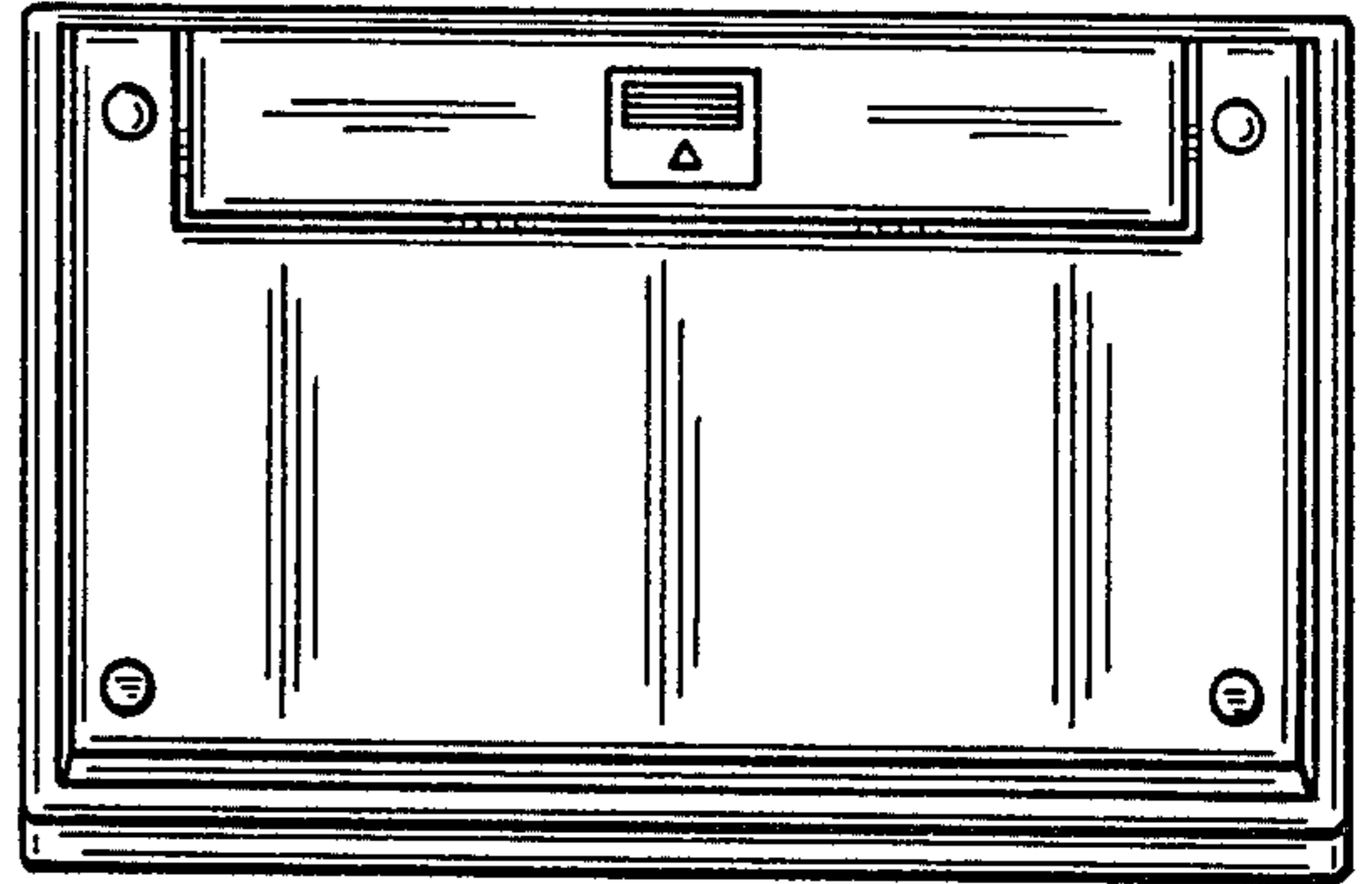
DESCRIPTION

FIG. 1 is a top plan view of an electronic sphygmomanometer showing my new design;
FIG. 2 is a bottom plan view thereof;
FIG. 3 is a front elevational view thereof;
FIG. 4 is a rear elevational view thereof;
FIG. 5 is a right side elevational view thereof;
FIG. 6 is a left side elevational view thereof; and
FIG. 7 is an enlarged sectional view thereof taken along the line 7—7 of FIG. 1.

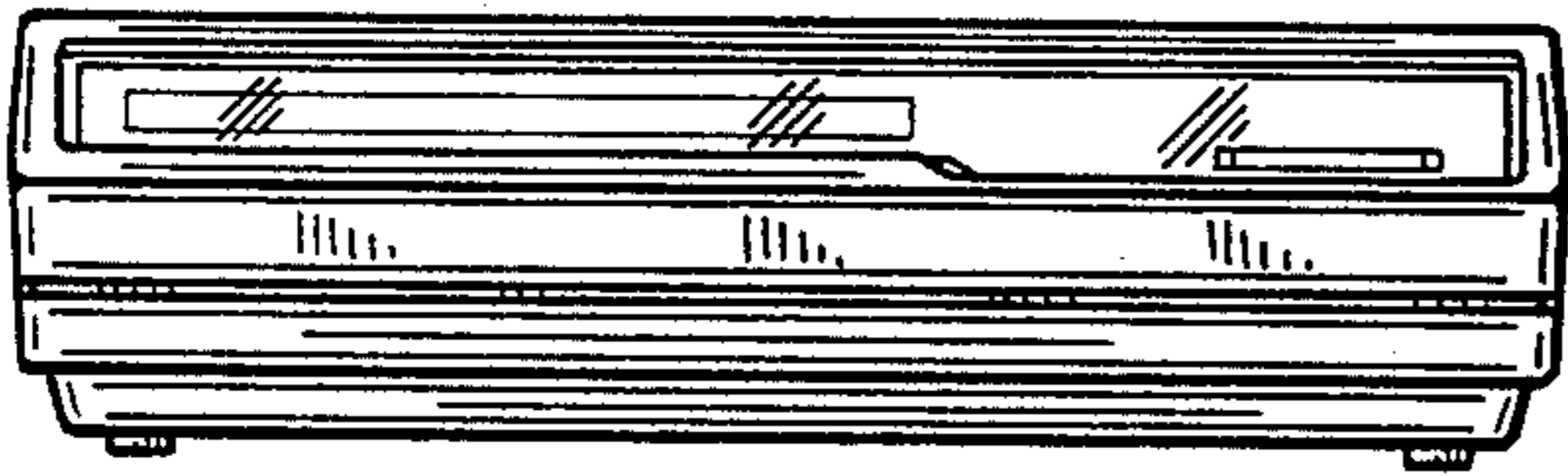




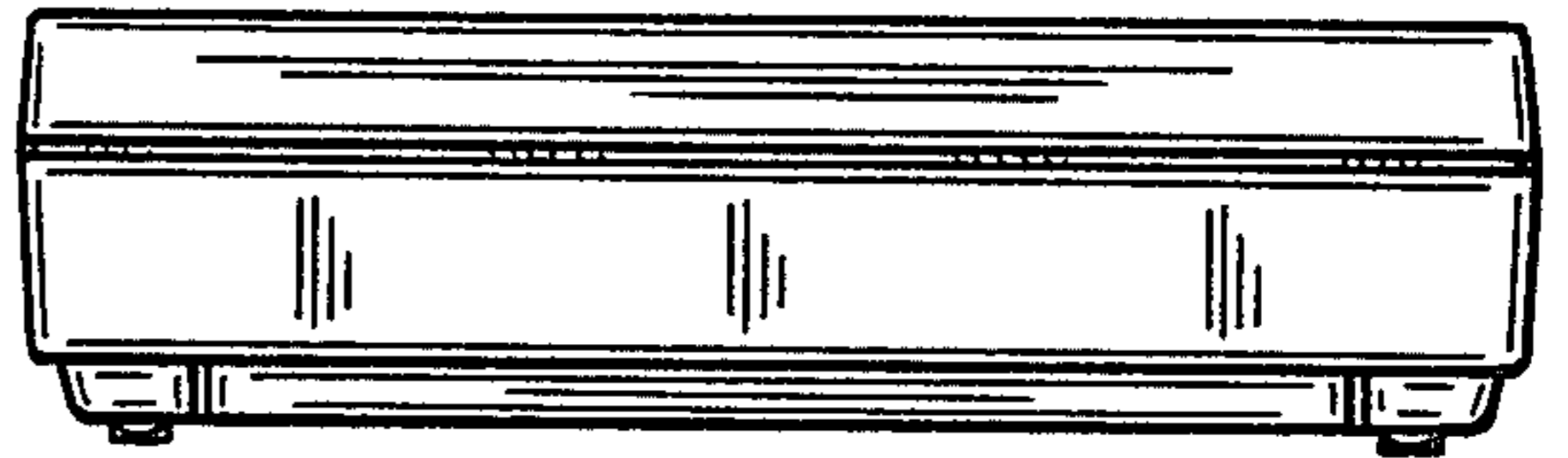
FIG_1



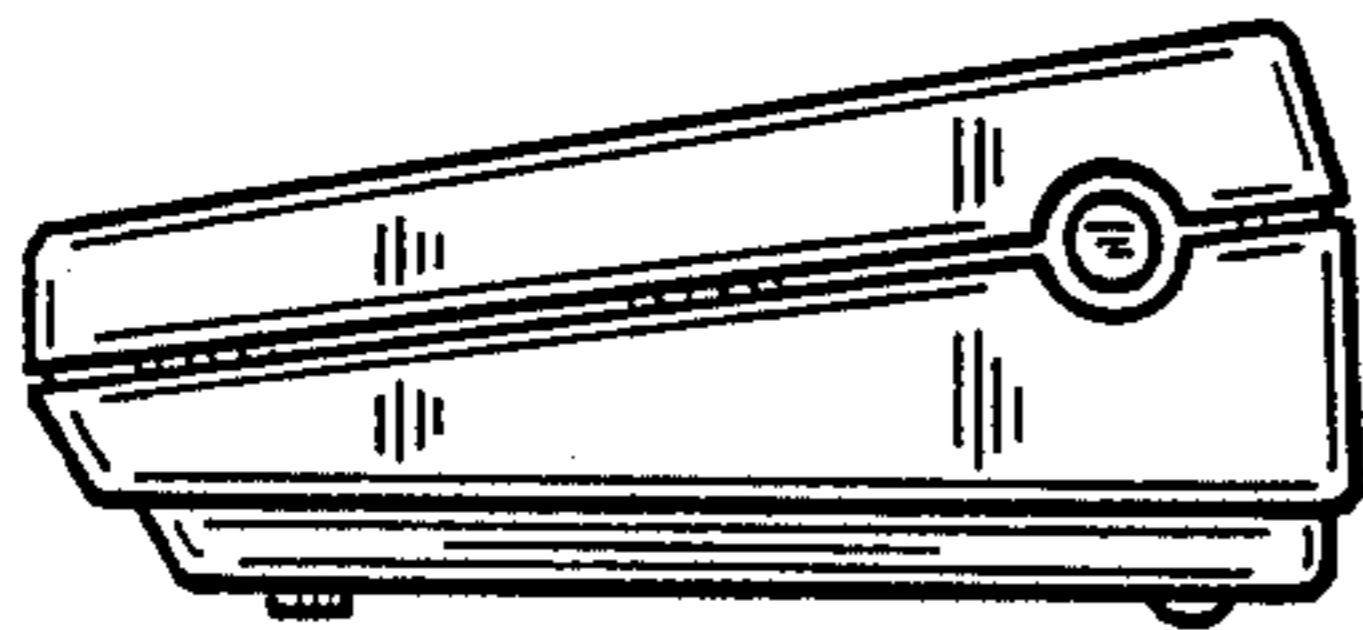
FIG_2



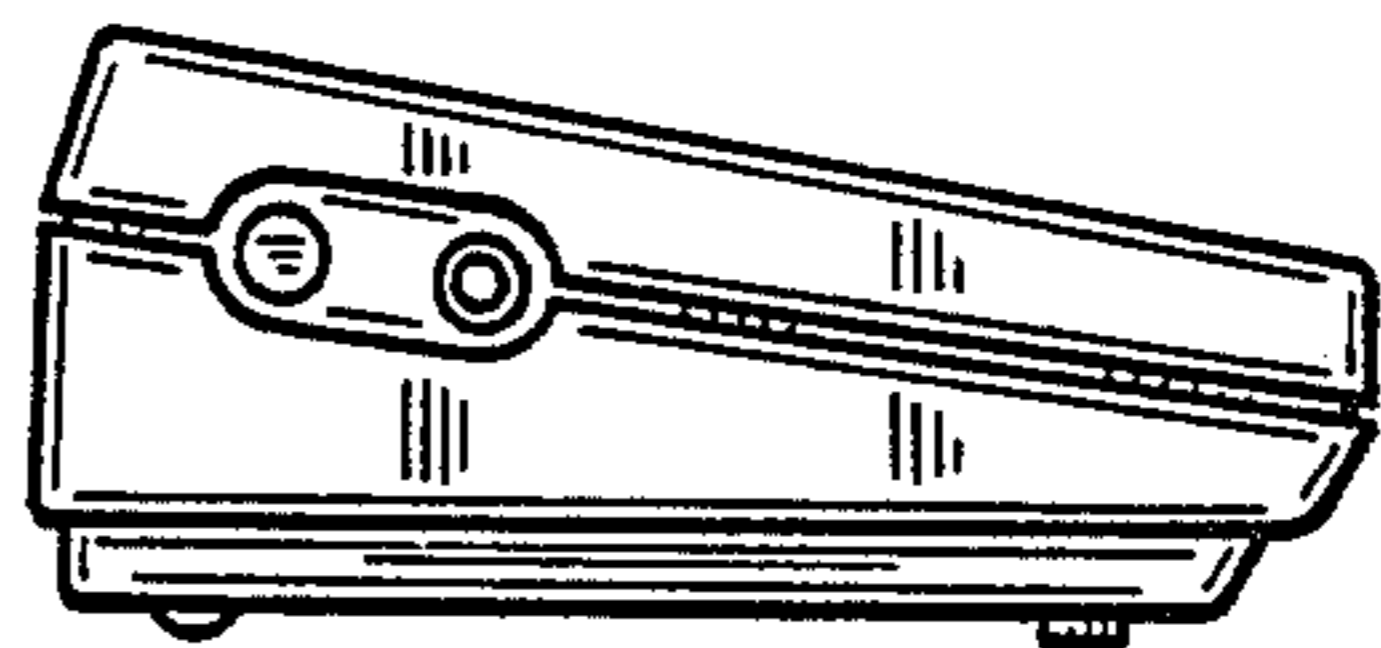
FIG_3



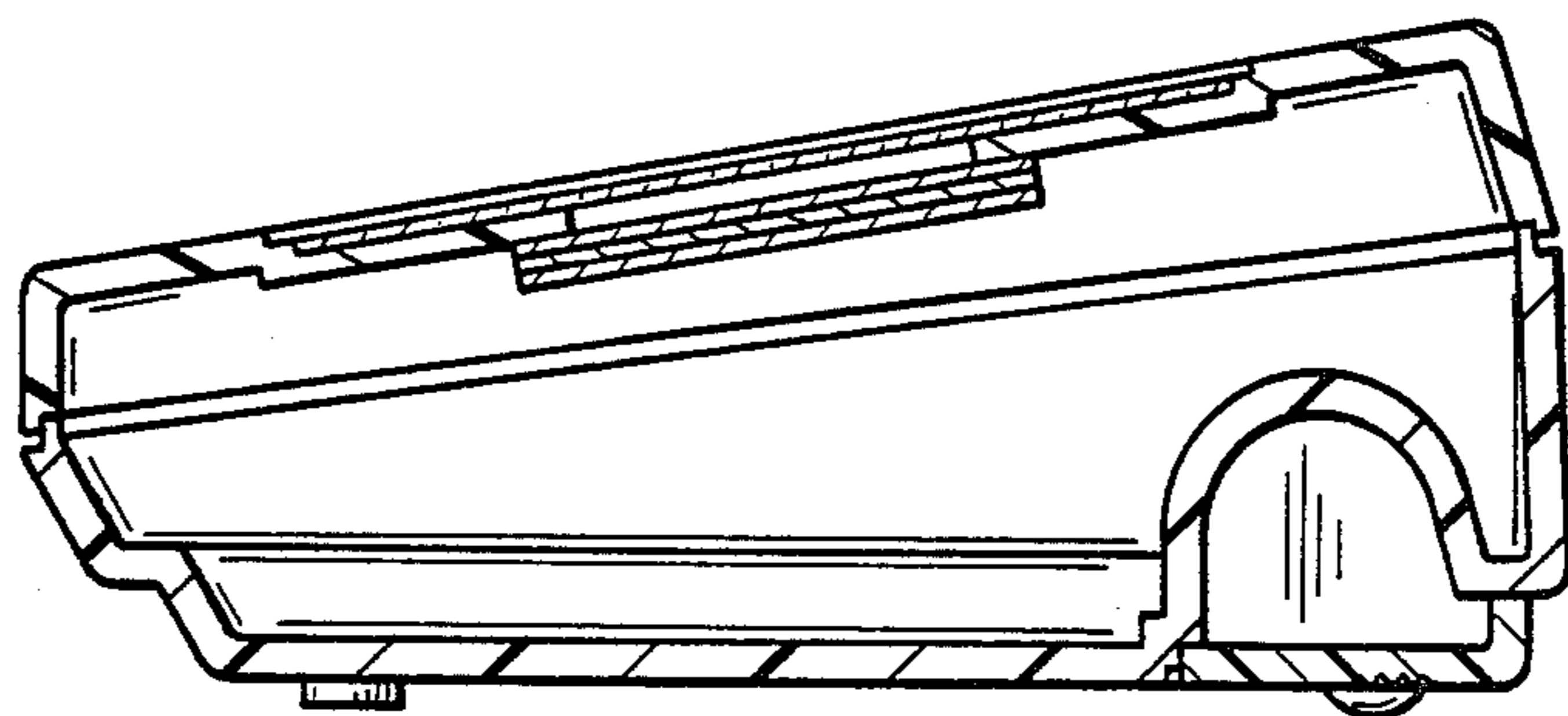
FIG_4



FIG_5



FIG_6



FIG_7