

[54] AUTOMOBILE LIFT GATE

[75] Inventor: Ramon L. Everts, Milford, Mich.

[73] Assignee: Ford Motor Company, Dearborn, Mich.

[\*\*] Term: 14 Years

[21] Appl. No.: 748,653

[22] Filed: Jun. 25, 1985

[52] U.S. Cl. .... D12/196

[58] Field of Search ..... D12/196; 296/50, 56, 296/57 R

[56] References Cited

PUBLICATIONS

Motor Trend, 4/84, p. 13, Lift Gate of Ford Country Squire Station Wagon, top of page.

Motor Trend, 9/84, p. 17, Lift Gate of Ford Taurus Station Wagon, bottom left side of page.

Primary Examiner—James M. Gandy

Attorney, Agent, or Firm—Daniel M. Stock; Clifford L. Sadler

[57] CLAIM

The ornamental design for an automobile lift gate, as shown and described.

DESCRIPTION

FIG. 1 is a perspective view of an automobile lift gate showing my new design;

FIG. 2 is an enlarged front elevation view thereof;

FIG. 3 is an enlarged front perspective view thereof;

FIG. 4 is an enlarged vertical cross-sectional view taken along line IV—IV of FIG. 2;

FIG. 5 is an enlarged vertical cross-sectional view taken along line V—V of FIG. 2;

FIG. 6 is an enlarged horizontal cross-sectional view taken along line VI—VI of FIG. 2;

FIG. 7 is an enlarged horizontal cross-sectional view taken along line VII—VII of FIG. 2;

FIG. 8 is an enlarged horizontal cross-sectional view taken along line VIII—VIII of FIG. 2; and

FIG. 9 is an enlarged oblique cross-sectional view taken along line IX—IX of FIG. 3.

It is to be understood that the broken lines shown in the drawing are for illustrative purposes only and form no part of the claimed design and that the rear of the lift gate is plain and unornamented.

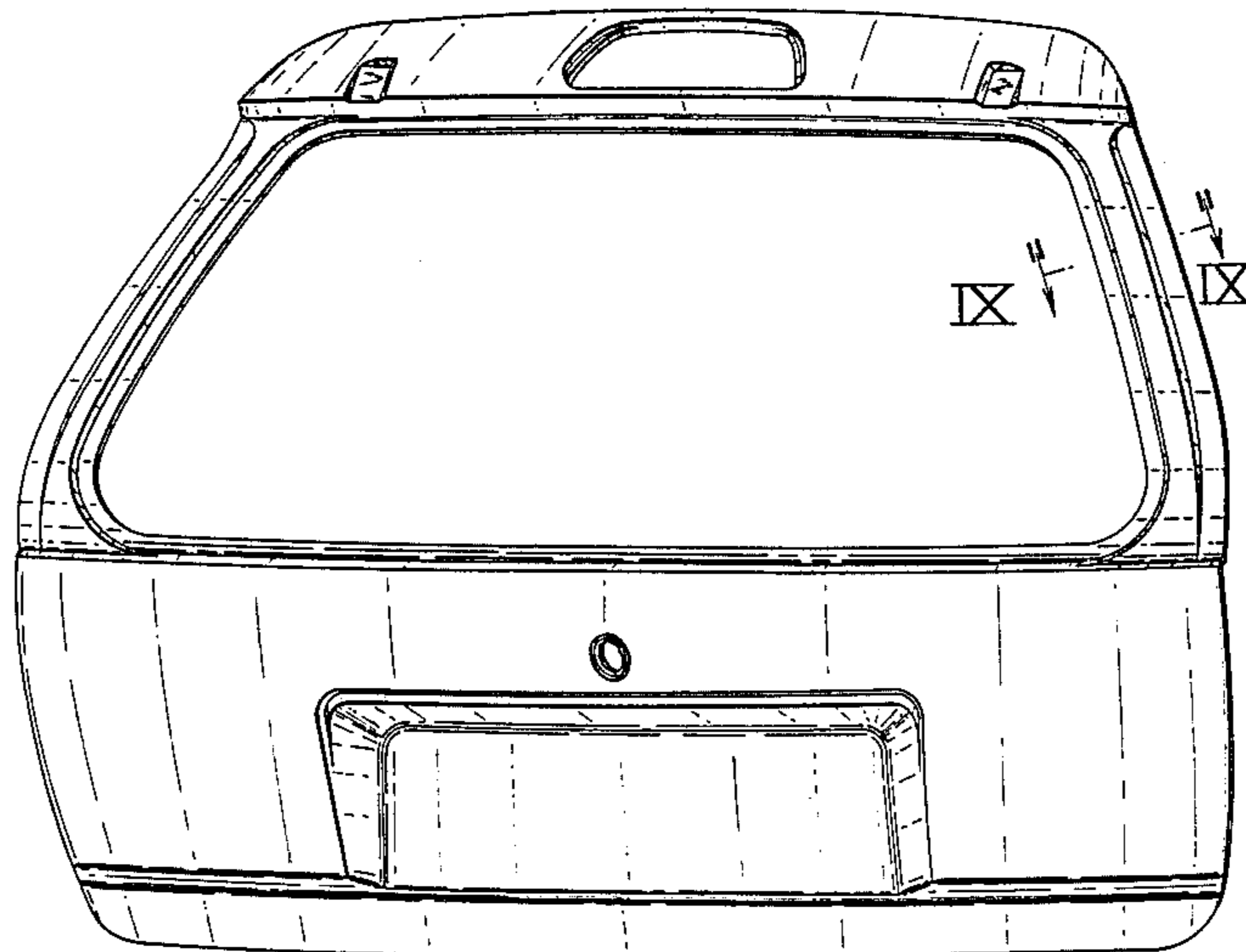

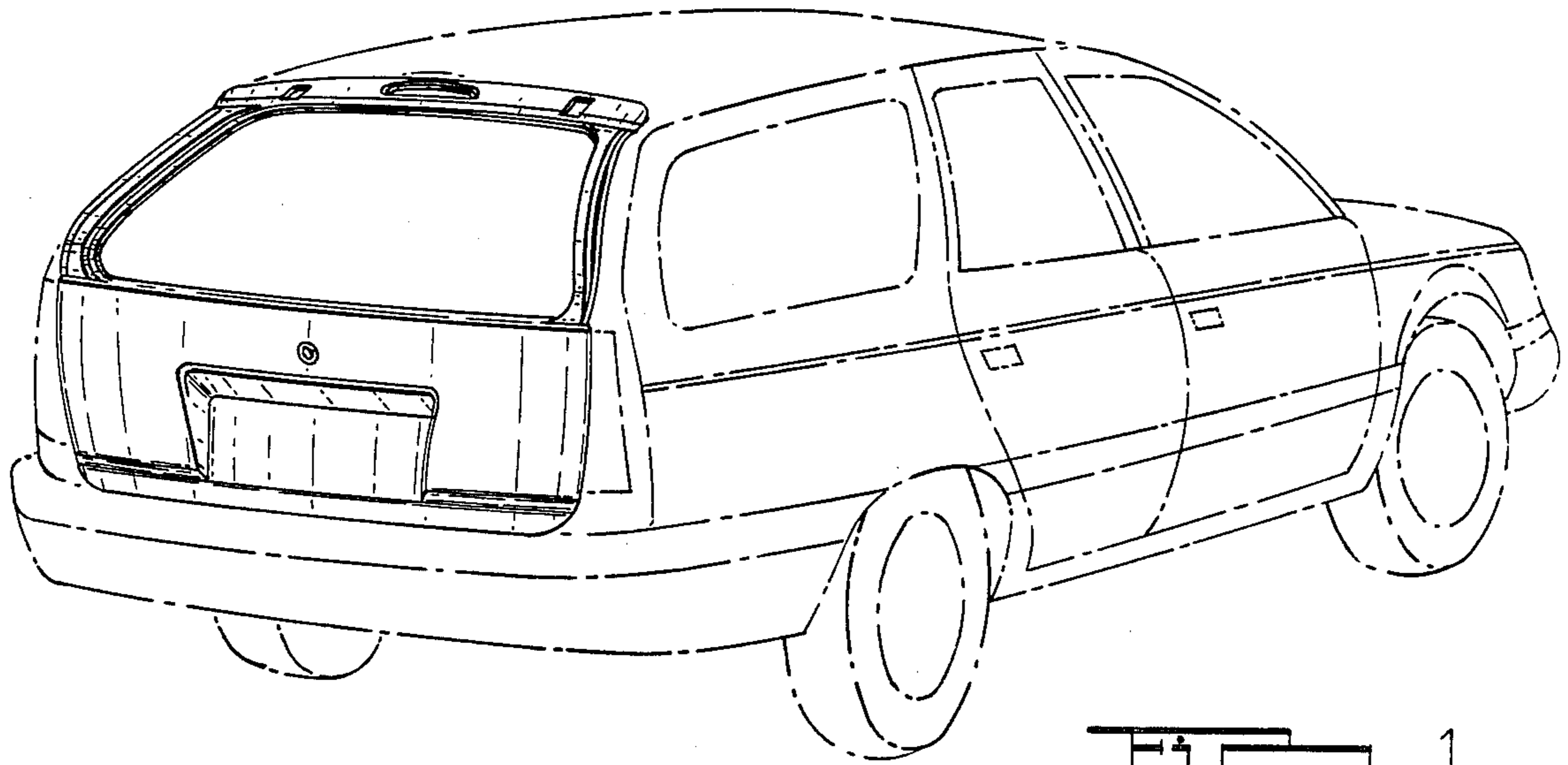

FIG. 1.

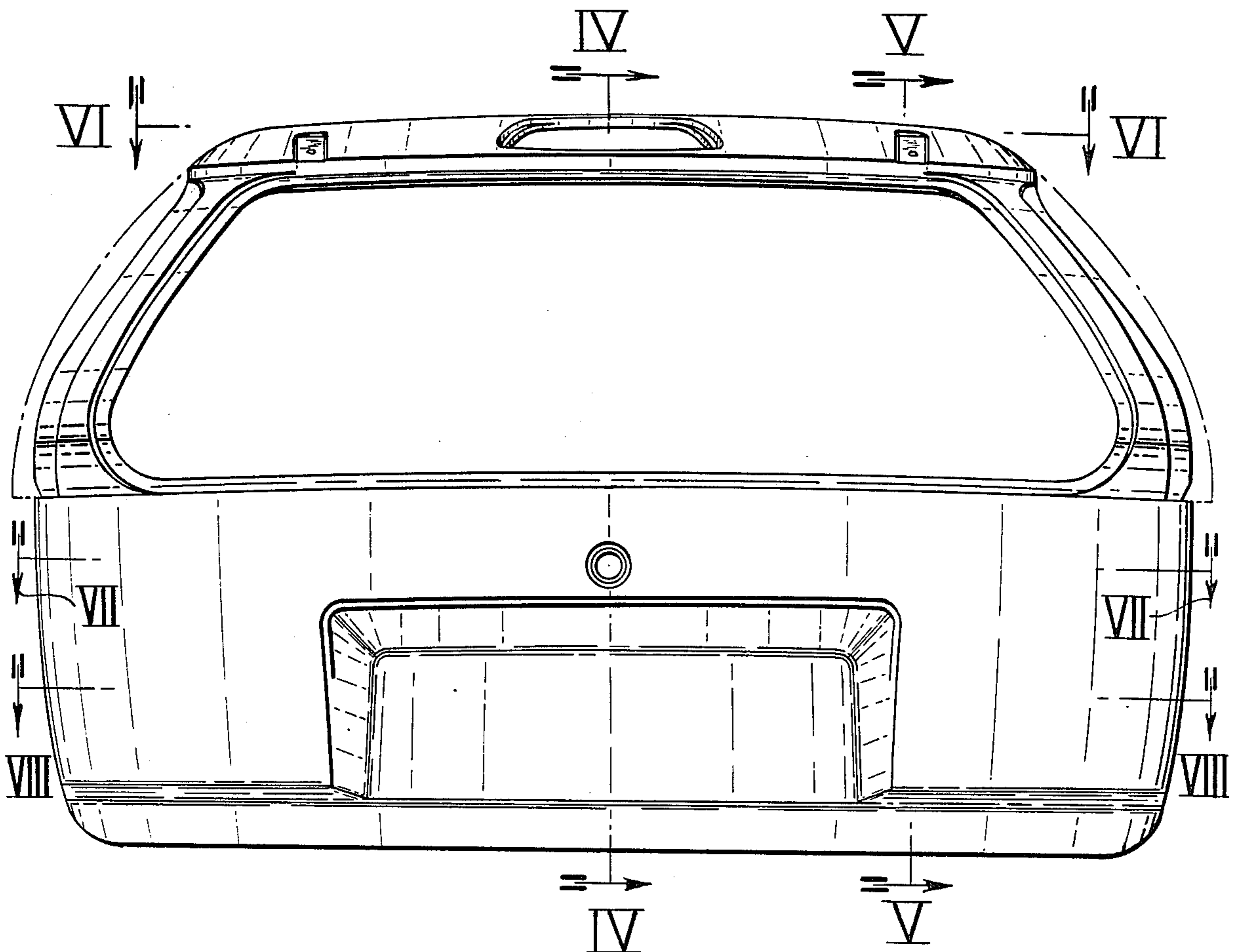

FIG. 2.

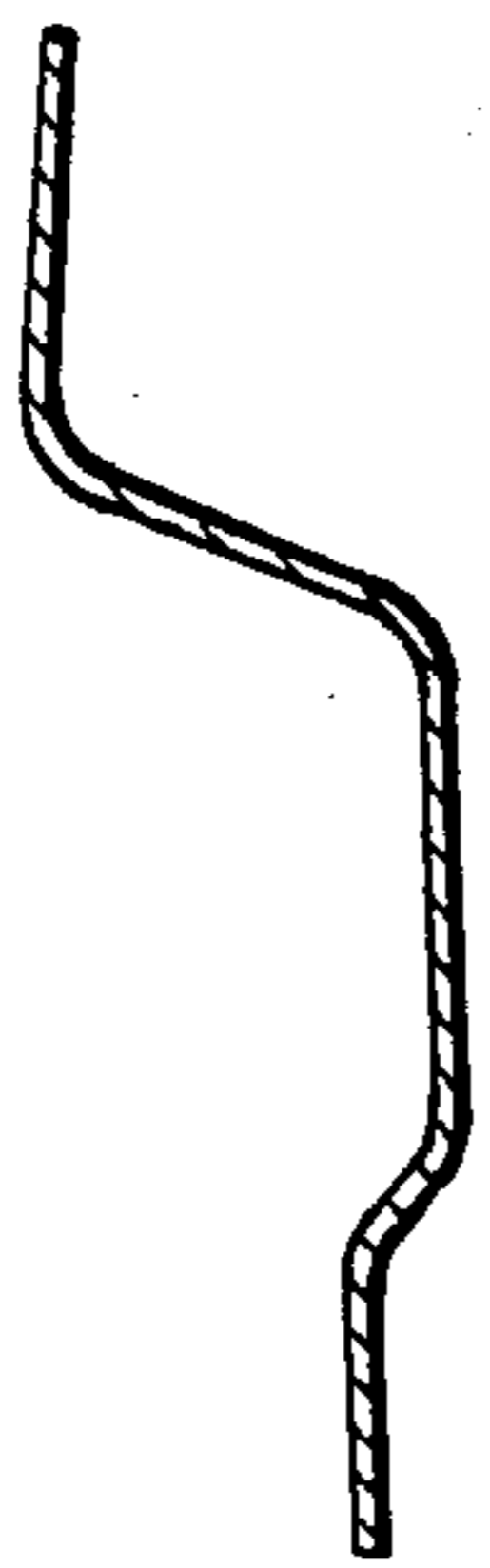
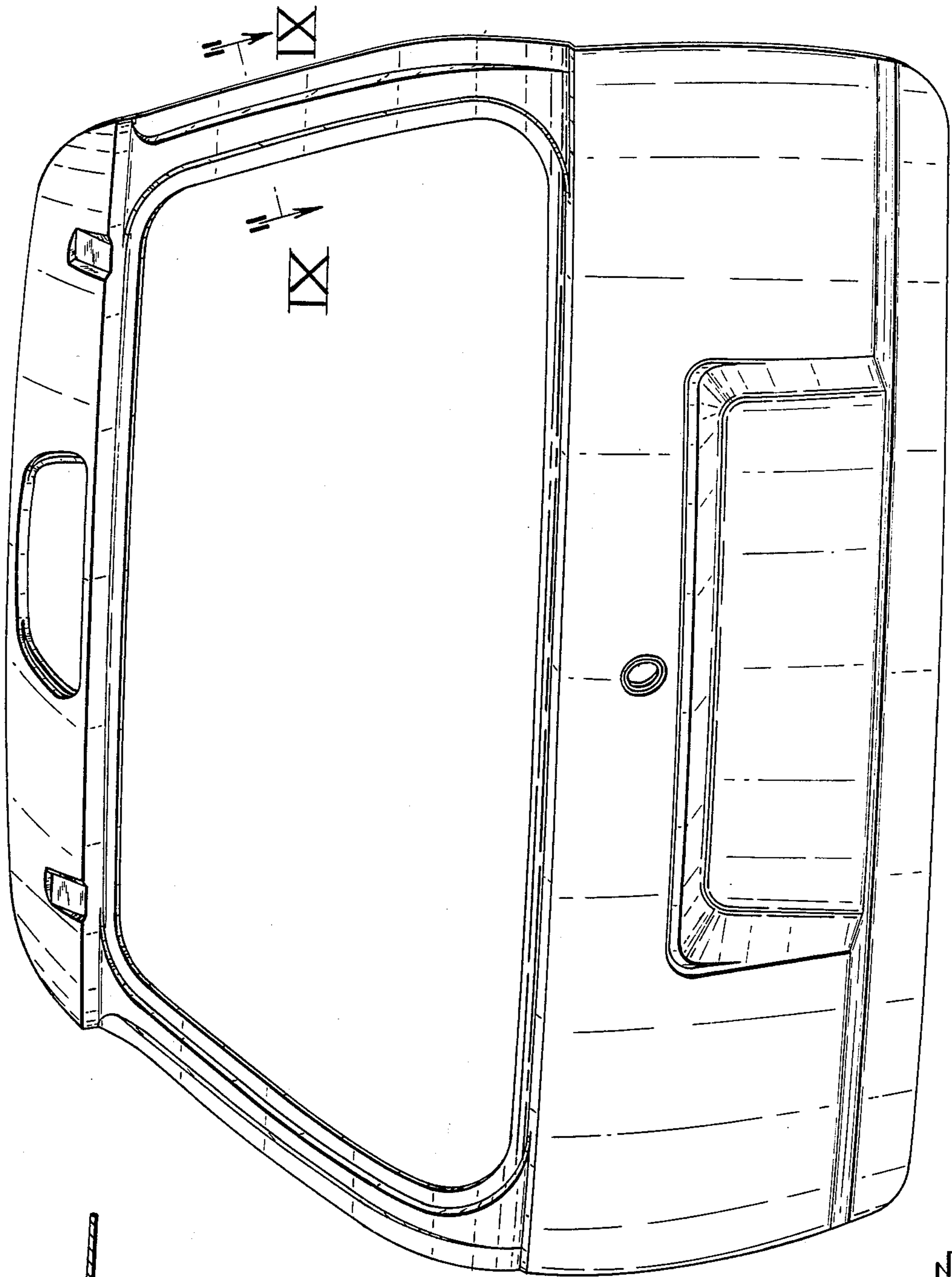

FIG. 9.

FIG. 10.

