

# United States Patent [19]

Mashburn et al.

[11] Patent Number: **Des. 296,984**

[45] Date of Patent: **\*\* Aug. 2, 1988**

[54] **CLAMP**

[76] Inventors: **James S. Mashburn; Jerry P. Mashburn**, both of 1201 E. Hill St., Long Beach, Calif. 90806

[\*\*] Term: **14 Years**

[21] Appl. No.: **809,143**

[22] Filed: **Dec. 16, 1985**

[52] U.S. Cl. .... **D8/396**

[58] Field of Search ..... **D8/394-396; 24/489, 494, 513, 517; 248/65, 74.1; D23/265**

[56] **References Cited**

**U.S. PATENT DOCUMENTS**

D. 142,834	11/1945	Campbell	.....	D23/265
D. 199,695	12/1964	Engman	.....	D8/396
D. 206,024	10/1966	Singer	.....	D8/396
D. 291,061	7/1987	Nakatani	.....	D8/396
1,925,699	9/1933	Marshall	.....	24/517

2,917,799	12/1959	Meighan	.....	24/136 R
3,084,409	4/1963	Griffiths	.....	248/65
3,523,669	8/1970	Avallone	.....	248/74.1

*Primary Examiner*—B. J. Bullock  
*Attorney, Agent, or Firm*—Roger A. Marrs

[57] **CLAIM**

The ornamental design for a clamp, substantially as shown and described.

**DESCRIPTION**

FIG. 1 is a side elevational view showing our new design for a clamp;  
FIG. 2 is an end elevational view taken from the right of FIG. 1;  
FIG. 3 is an end elevational view taken from the left of FIG. 1;  
FIG. 4 is a bottom plan view thereof;  
FIG. 5 is a top plan view thereof; and  
FIG. 6 is a perspective view thereof, in the open position.

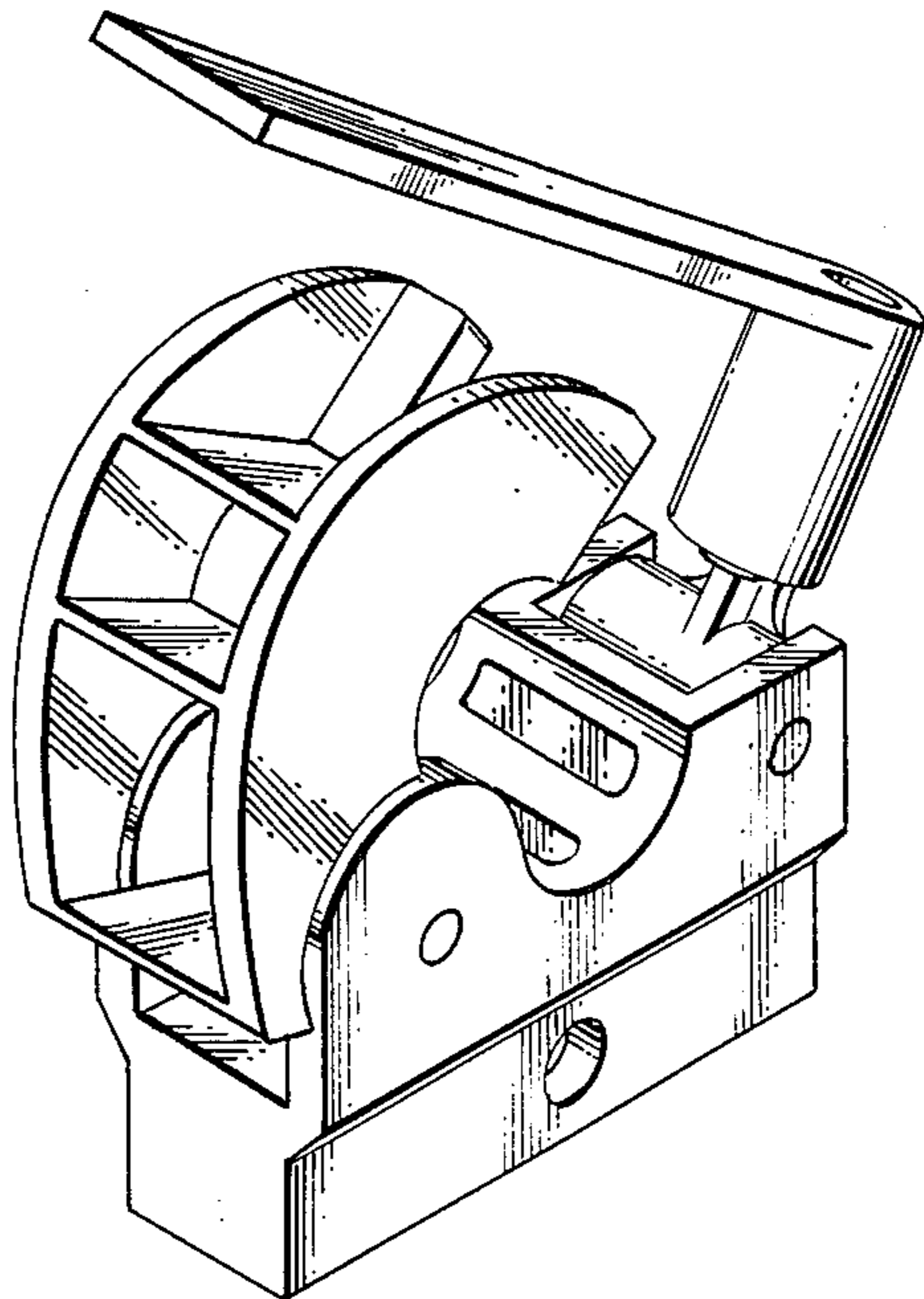
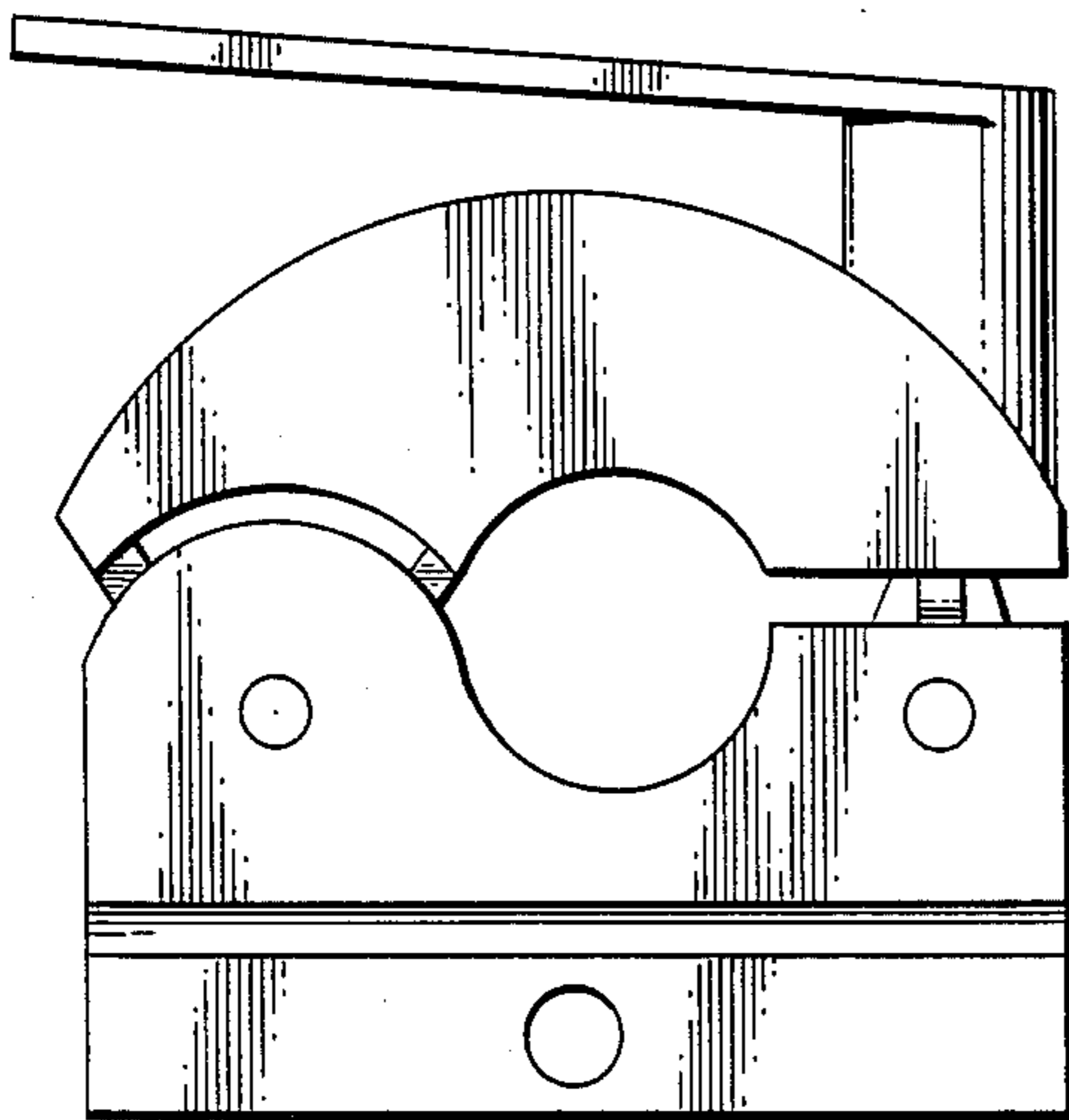

FIG. 1

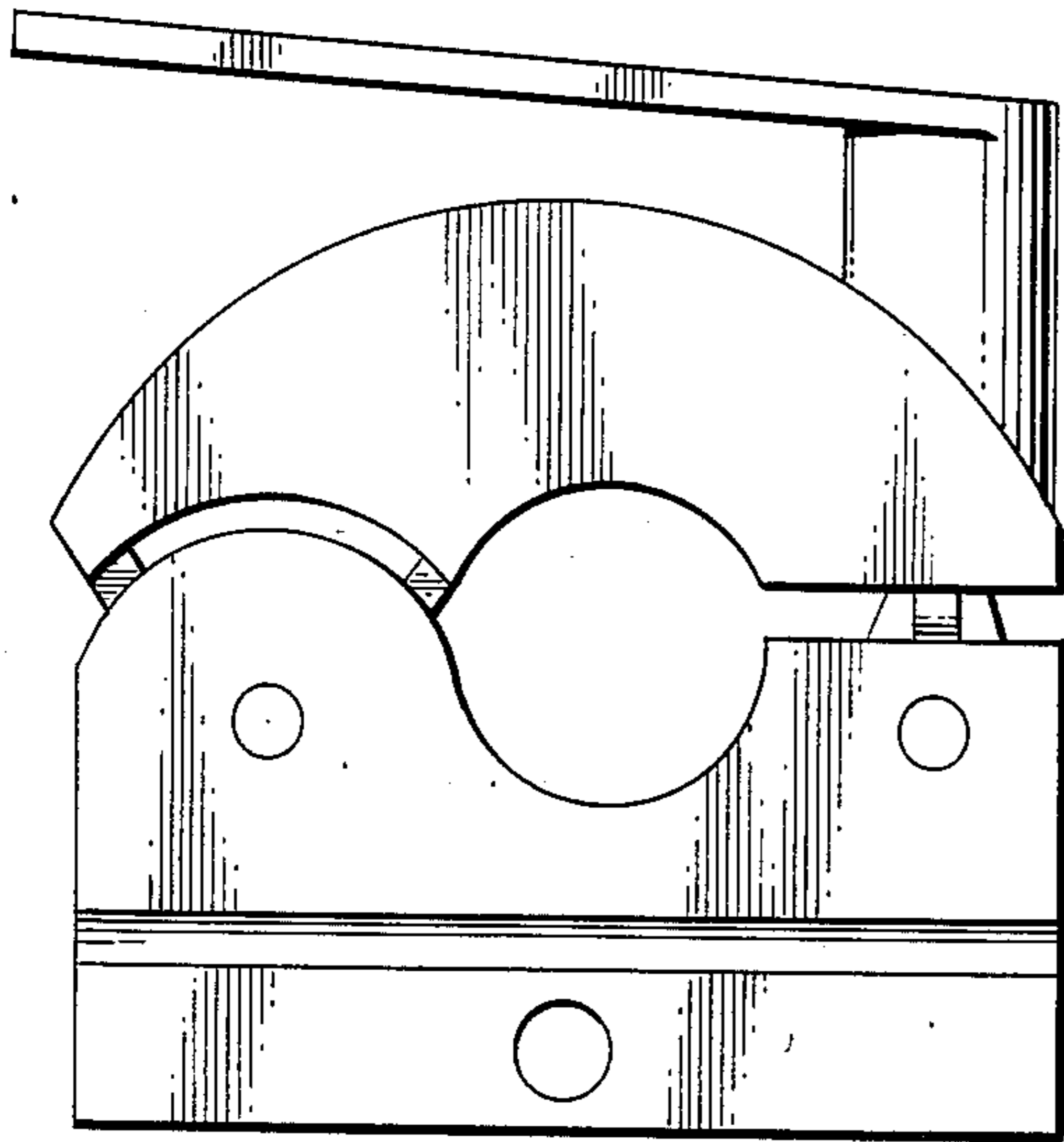

FIG. 2

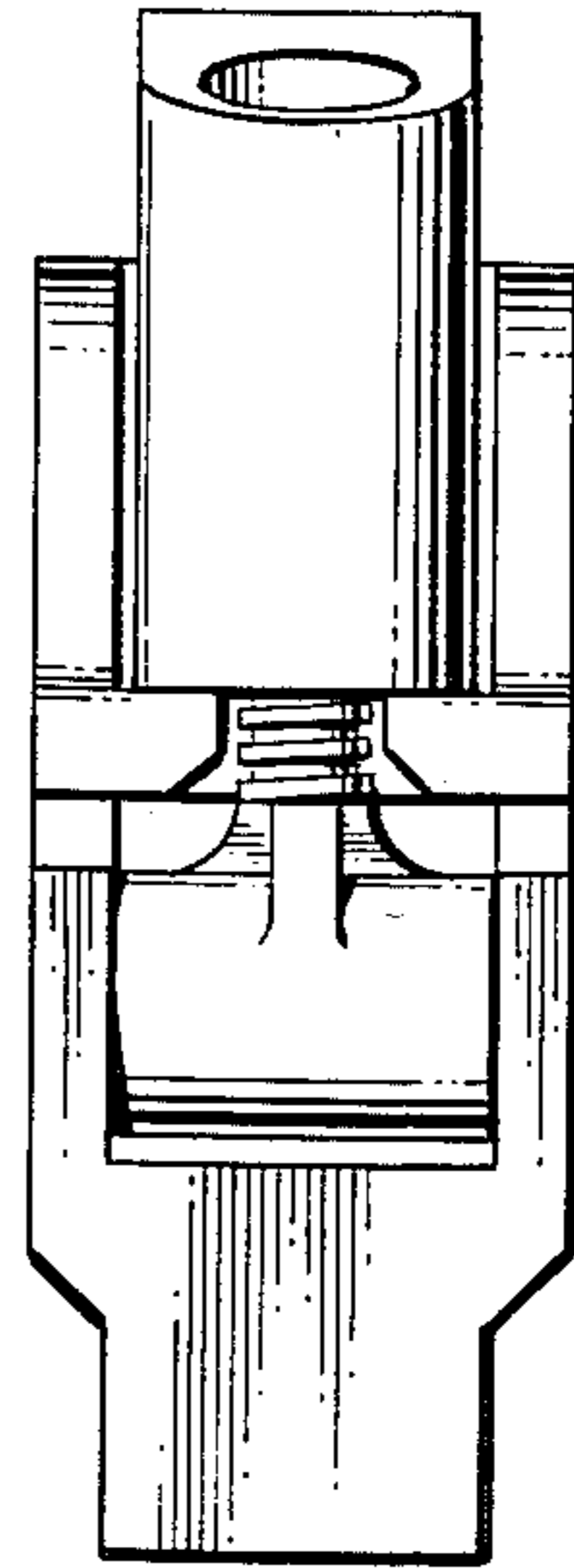

FIG. 3

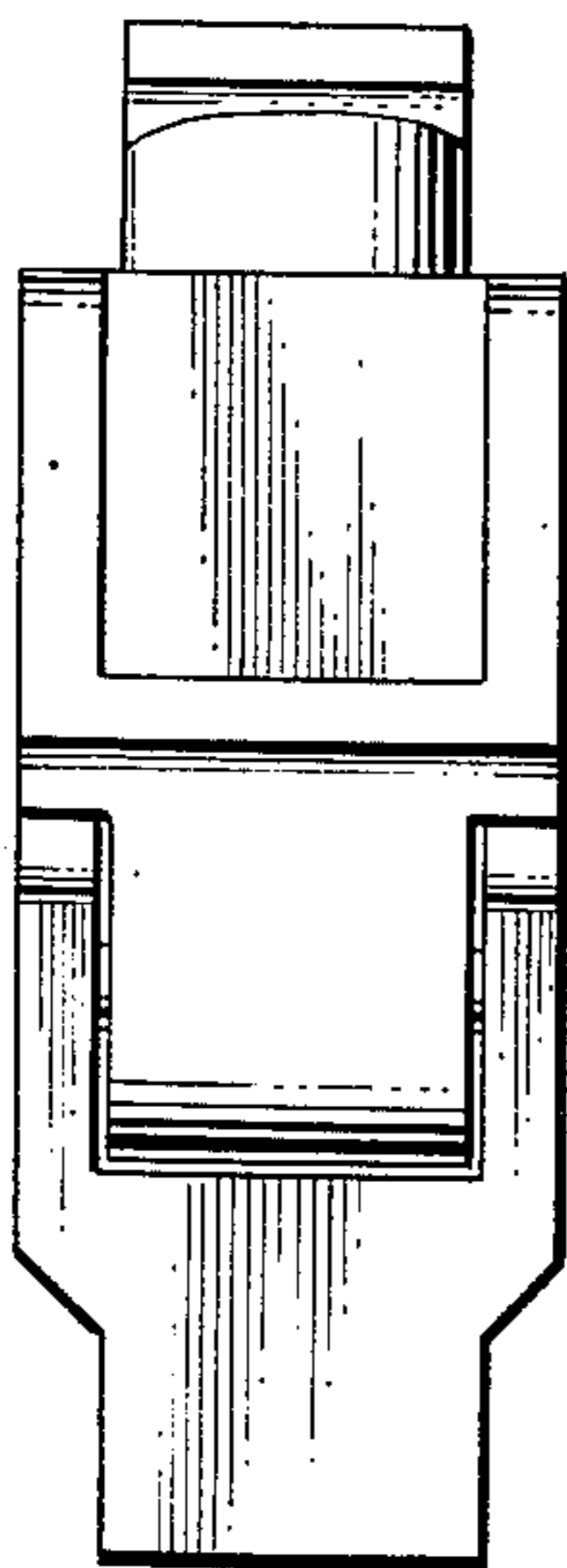

FIG. 4

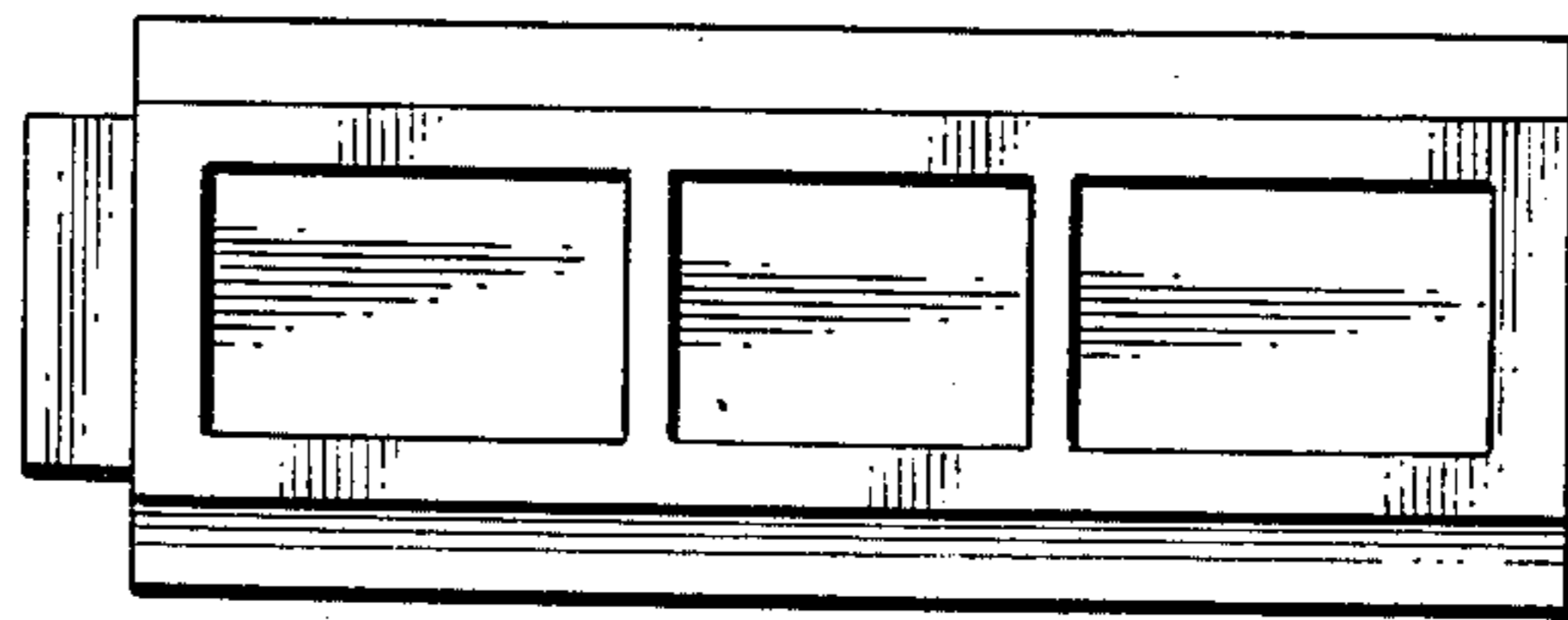

FIG. 5

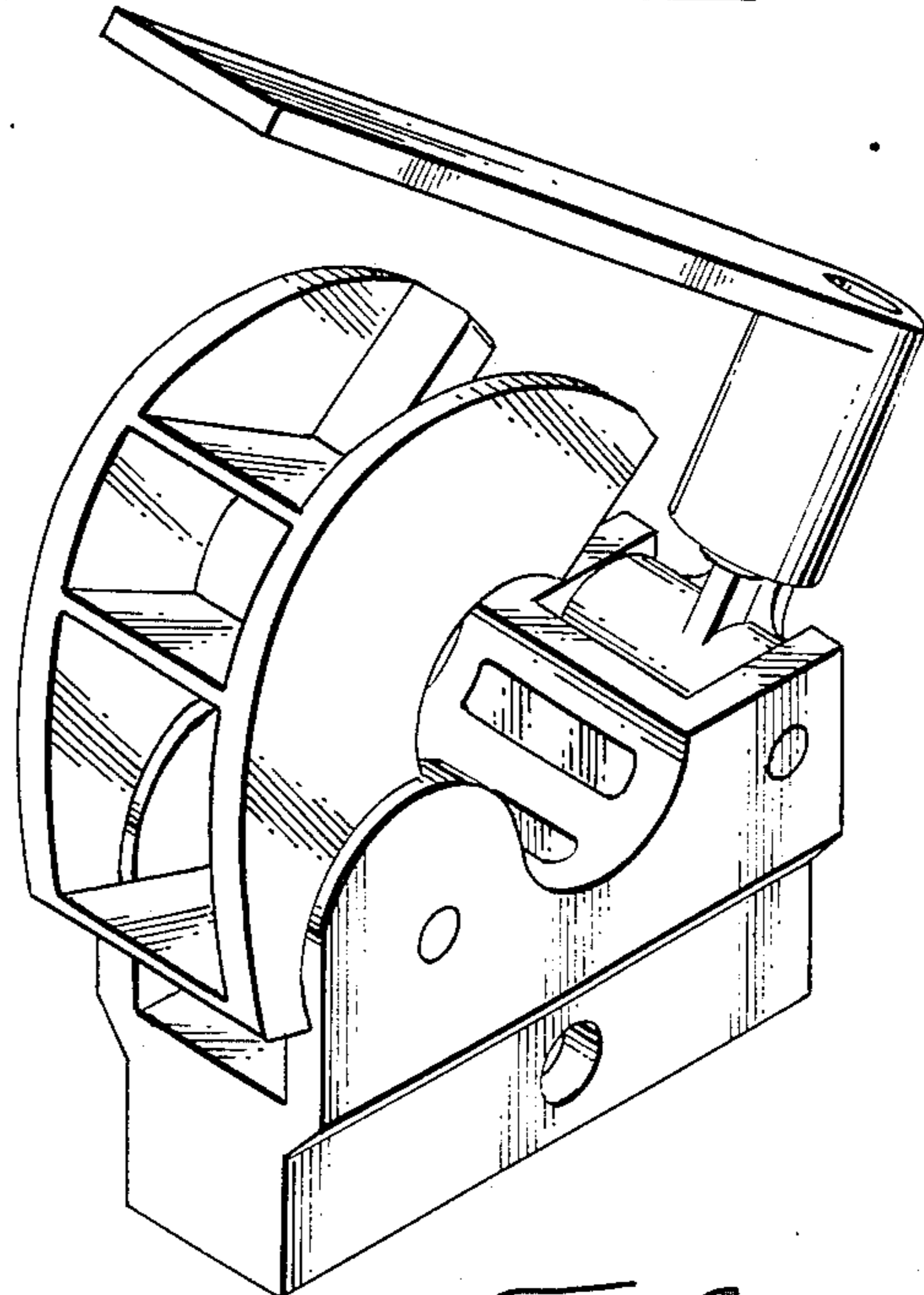
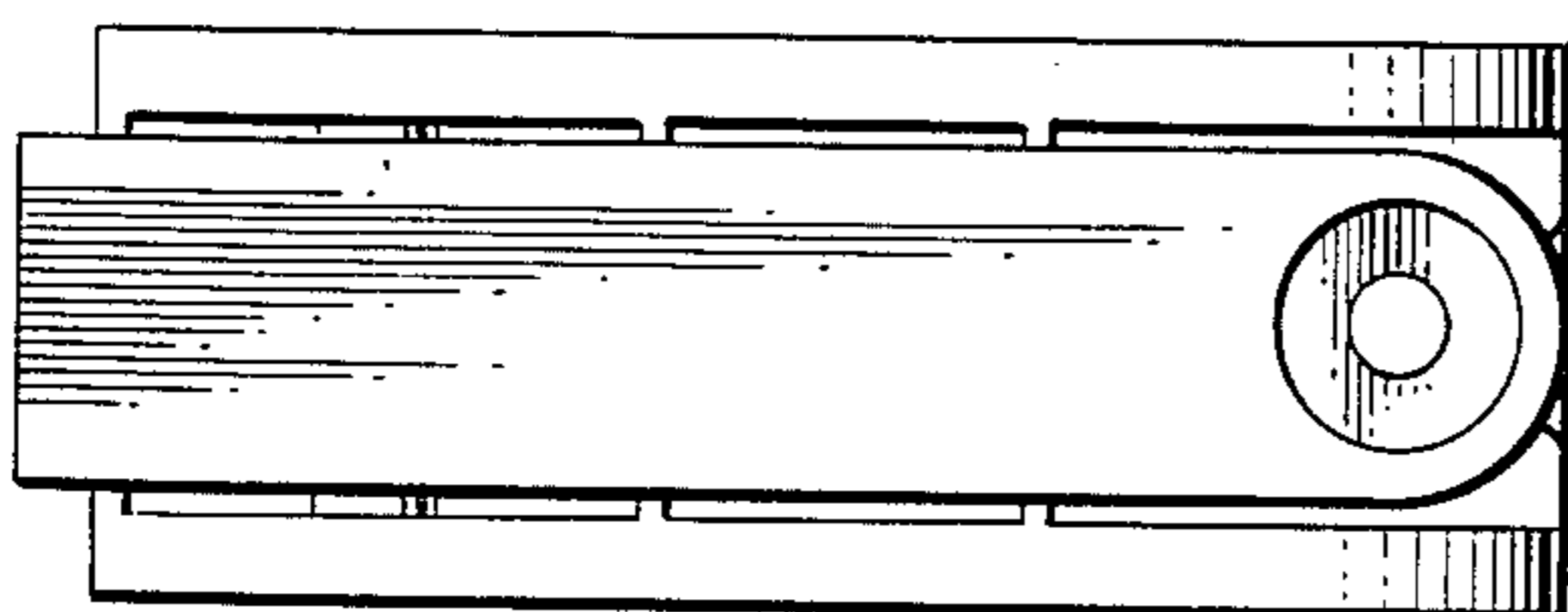

FIG. 6