

[54] **REFLECTOR FLUORESCENT LAMP**

[75] **Inventor: Peter C. J. Gallagher, Wayne, Pa.**
 [73] **Assignee: Electronic Advanced Systems Corp., West Conshohocken, Pa.**
 [**] **Term: 14 Years**
 [21] **Appl. No.: 742,732**
 [22] **Filed: Jun. 7, 1985**
 [52] **U.S. Cl. D26/26; D26/3**
 [58] **Field of Search D26/1, 2, 3, 26; 313/315, 317, 318, 113, 115, 116, 493; 362/217, 297, 307, 309, 310, 311, 341, 347, 349, 350, 326**

Thermalflash Corporation Brochure, data sheet for 7 Watt Starlite Floodlamp.
 Energy Conservation Systems, "PL Lamp, Reflector Floods, Adapters . . .".
 Teron Lighting, "This is a 7 Watt Light Bulb".
 1982 GE Catalog, p. 3, form 9200.
 Wotan Dulux D, printed Oct. 1984.
 "Beta SP4 Clip-On Reflector", printed Oct. 1984, Beta Lighting.
 "The Philips SL*18 Bulb", Mar. 1984, printed, North American Philips Lighting.
 "Double Twin Tube", Sylvania Product Info. Bulletin FL-43, printed Mar. 1985.

Primary Examiner—Susan J. Lucas
Attorney, Agent, or Firm—Howson and Howson

[56] **References Cited**

U.S. PATENT DOCUMENTS

Re. 30,832	12/1981	La Giusa	313/113
D. 219,876	2/1971	Girard	D26/8
1,932,297	10/1933	Tucker	240/78
2,629,046	2/1953	Liberman	240/103
2,798,147	7/1957	Orsatti	362/216 X
3,341,731	9/1967	Wilson	313/113
4,197,480	4/1980	Ryan, Jr.	313/113 X
4,658,178	4/1987	Bradley et al.	313/113

OTHER PUBLICATIONS

1 page-of drawing, Appln. Ser. Nos. 512,621, and 512,622, P. C. J. Gallagher, Inventor.
 Freedom Lighting Brochure, "PERL".

[57] **CLAIM**

The ornamental design for a reflector fluorescent lamp, as shown and described.

DESCRIPTION

FIG. 1 is a top perspective view of a reflector fluorescent lamp showing my new design;
 FIG. 2 is a front elevational view thereof on a reduced scale, the rear being a mirror image;
 FIG. 3 is a top plan view thereof on a reduced scale; and
 FIG. 4 is a bottom plan view thereof on a reduced scale.
 The faceting on the top surface of the lens is partially shown for convenience of illustration, it being understood that the faceting is continuous over the area delineated in FIG. 3.

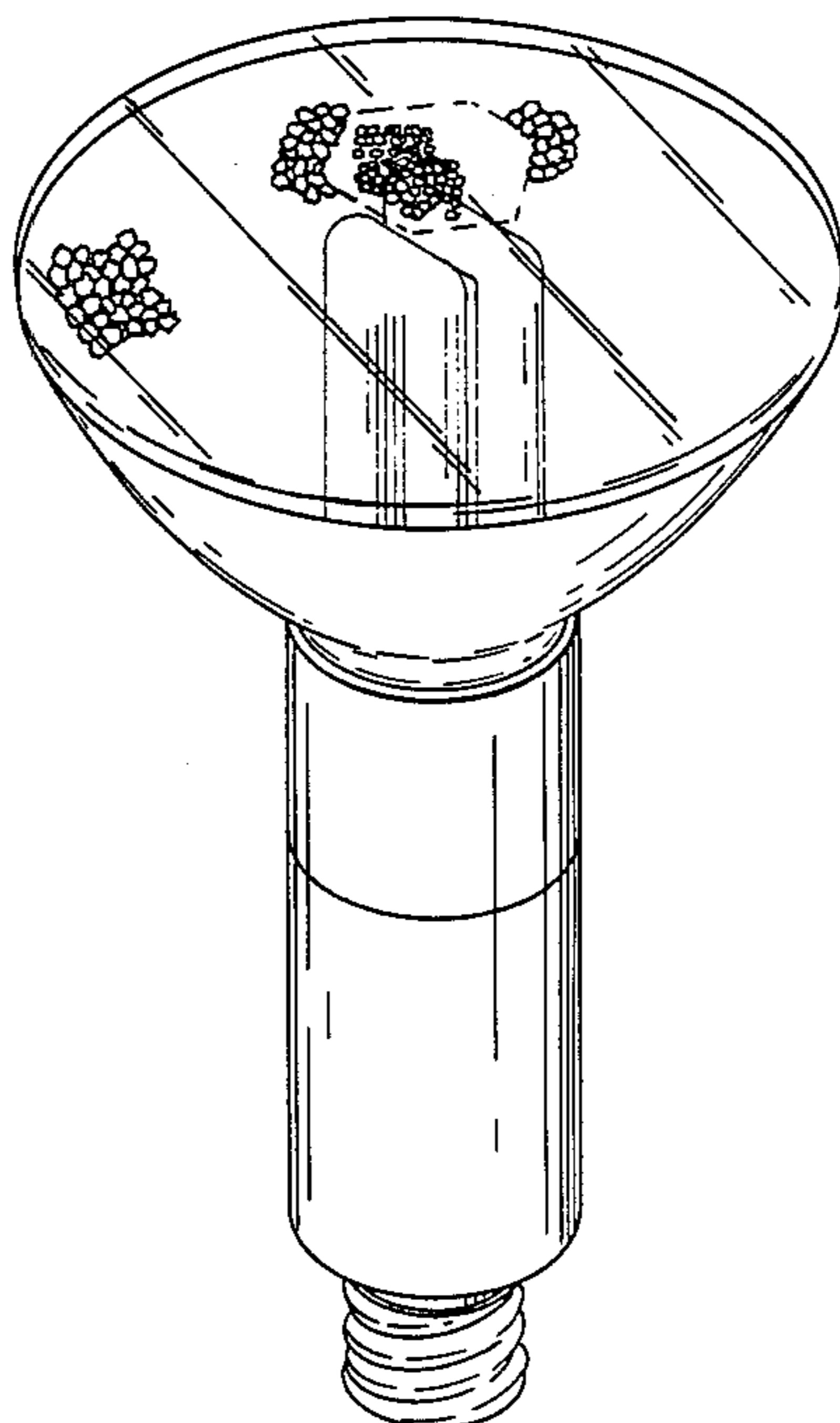

FIG. 1

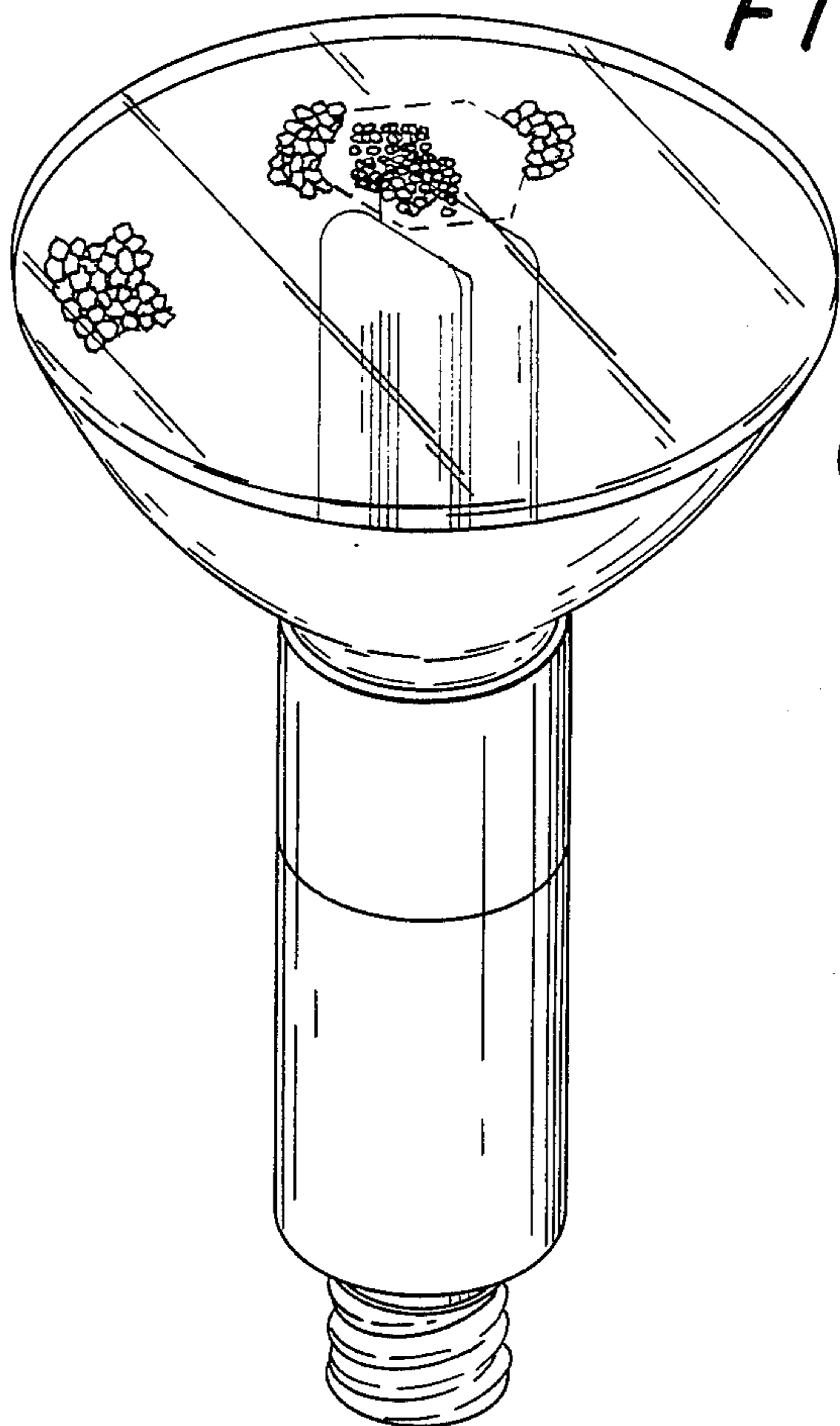

FIG. 2

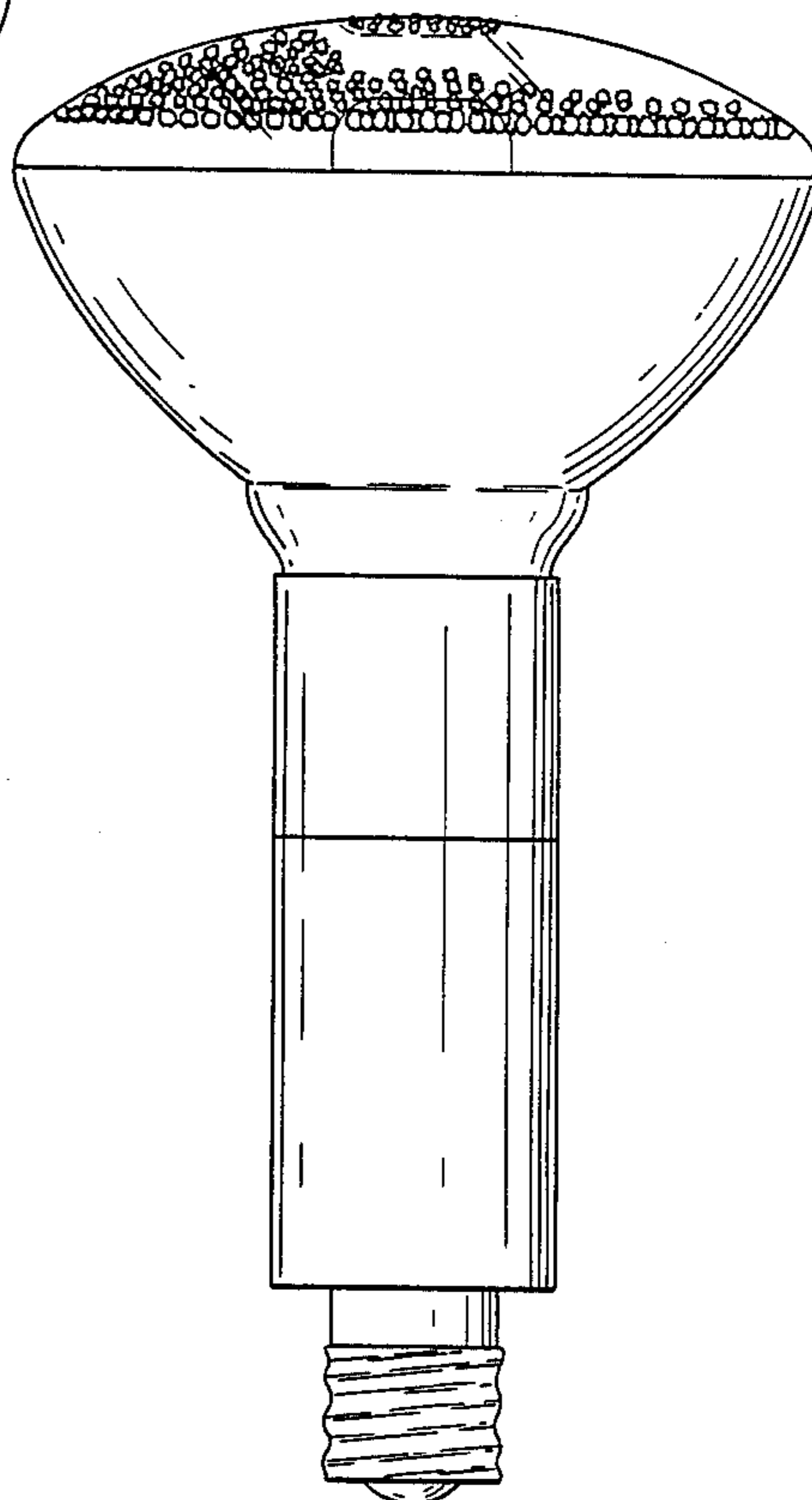

FIG. 3

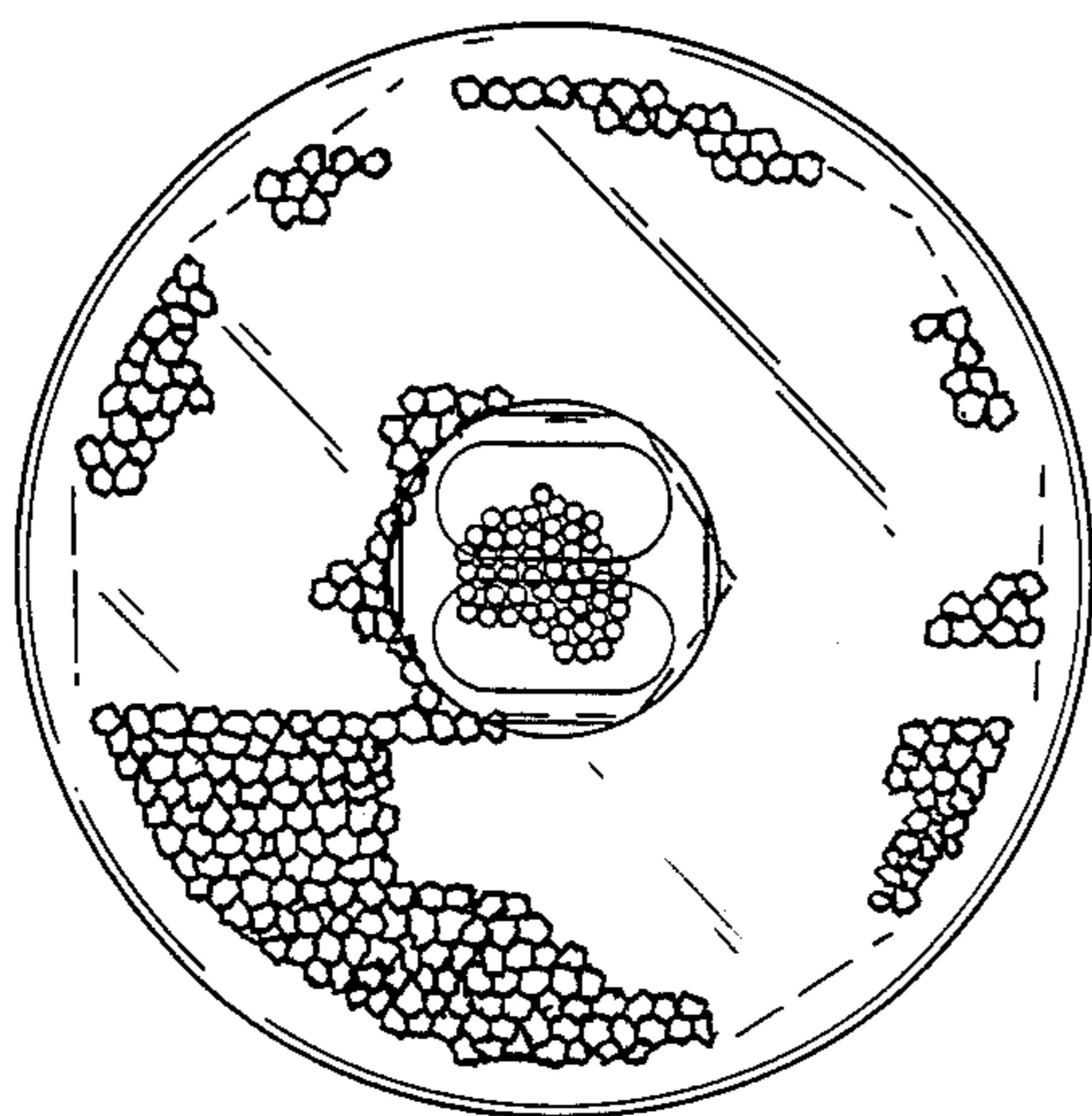

FIG. 4

