

[54] INJECTION MOLDING PRESS FOR DISKS OR THE LIKE

D. 266,327	9/1982	Haight et al.	D15/135
4,385,877	5/1983	Tanake	D15/135
4,425,091	1/1984	Prince	D15/135
4,544,519	10/1985	Schilke	425/547

[75] Inventor: Curt O. Lindell, Taby, Sweden

Primary Examiner—B. J. Bullock
Attorney, Agent, or Firm—Birch, Stewart, Kolasch & Birch

[73] Assignee: Toolex Alpha AB, Sundbyberg, Sweden

[**] Term: 14 Years

[21] Appl. No.: 765,535

[57] CLAIM

[22] Filed: Aug. 14, 1985

The ornamental design for an injection molding press for disks or the like, as shown and described.

[30] Foreign Application Priority Data

DESCRIPTION

Feb. 19, 1985 [SE] Sweden 85-0404

[52] U.S. Cl. D15/135

[58] Field of Search D15/135; 425/542, 547

FIG. 1 is a rear side view of an injection molding press, for disks or the like, showing my new design; FIG. 2 is a right end view thereof; FIG. 3 is a left end view thereof; FIG. 4 is a front side view thereof; FIG. 5 is a bottom view thereof; and FIG. 6 is a top view thereof.

[56] References Cited

U.S. PATENT DOCUMENTS

D. 234,874 4/1975 Aoki D15/135

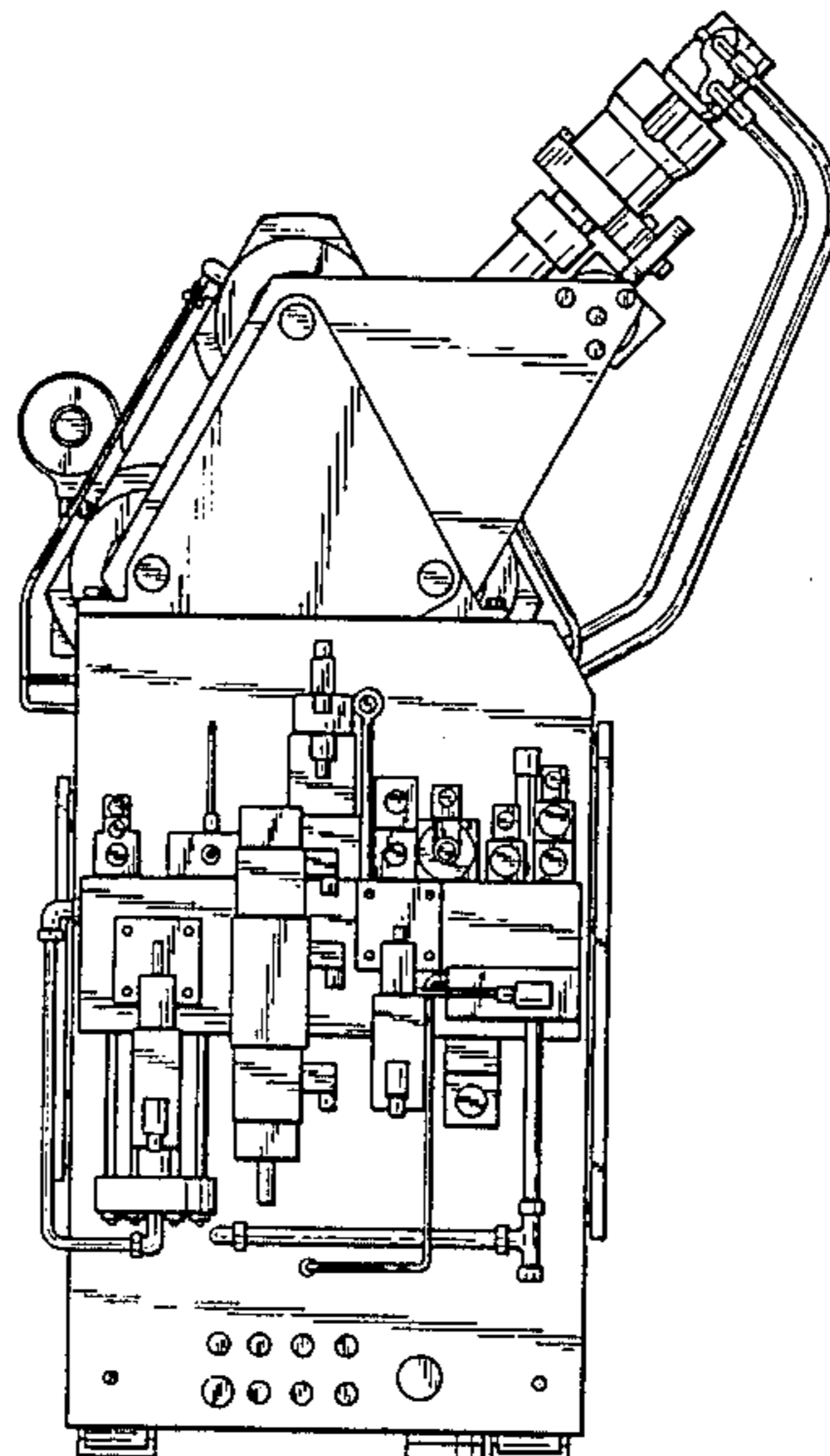
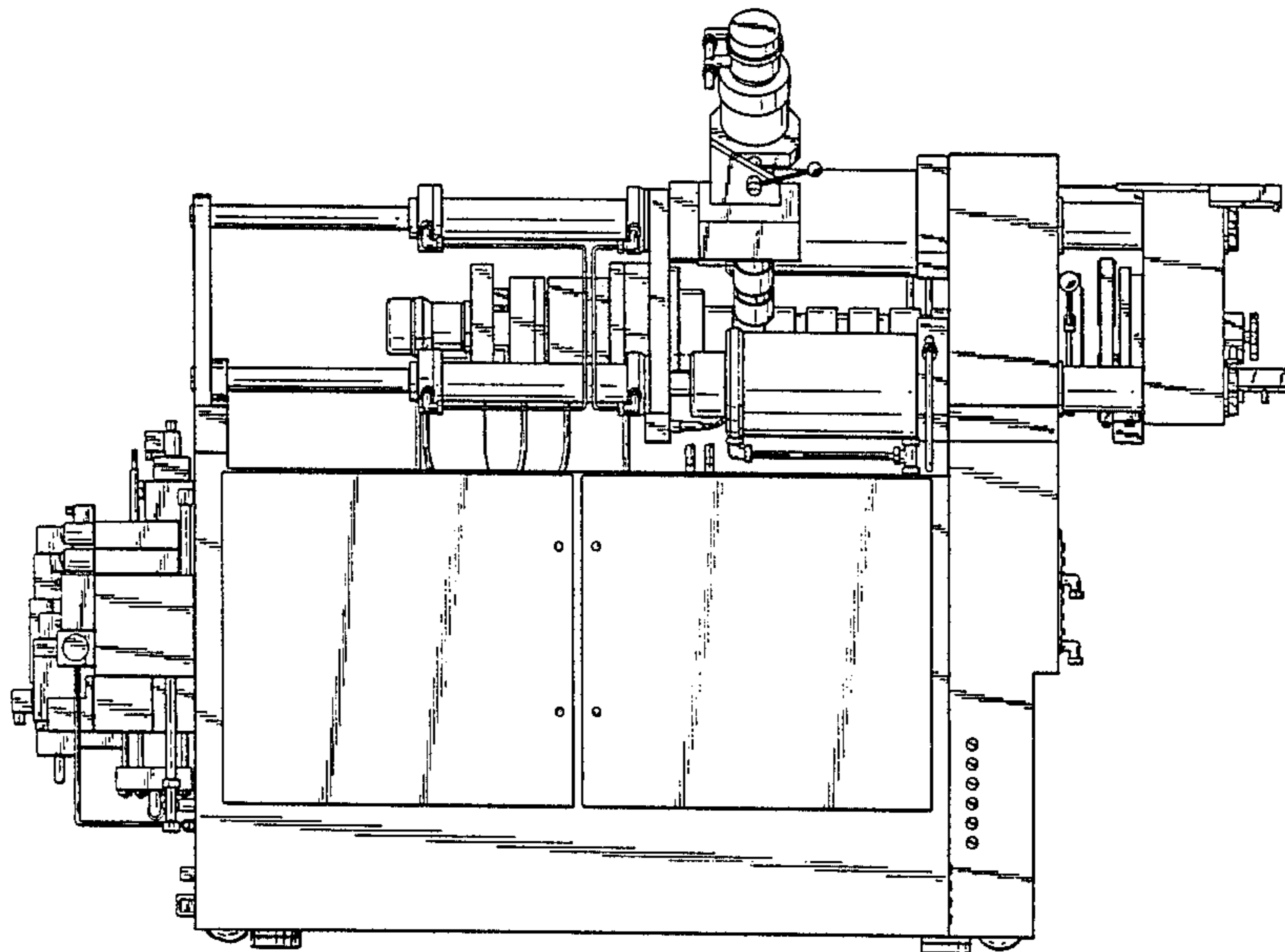

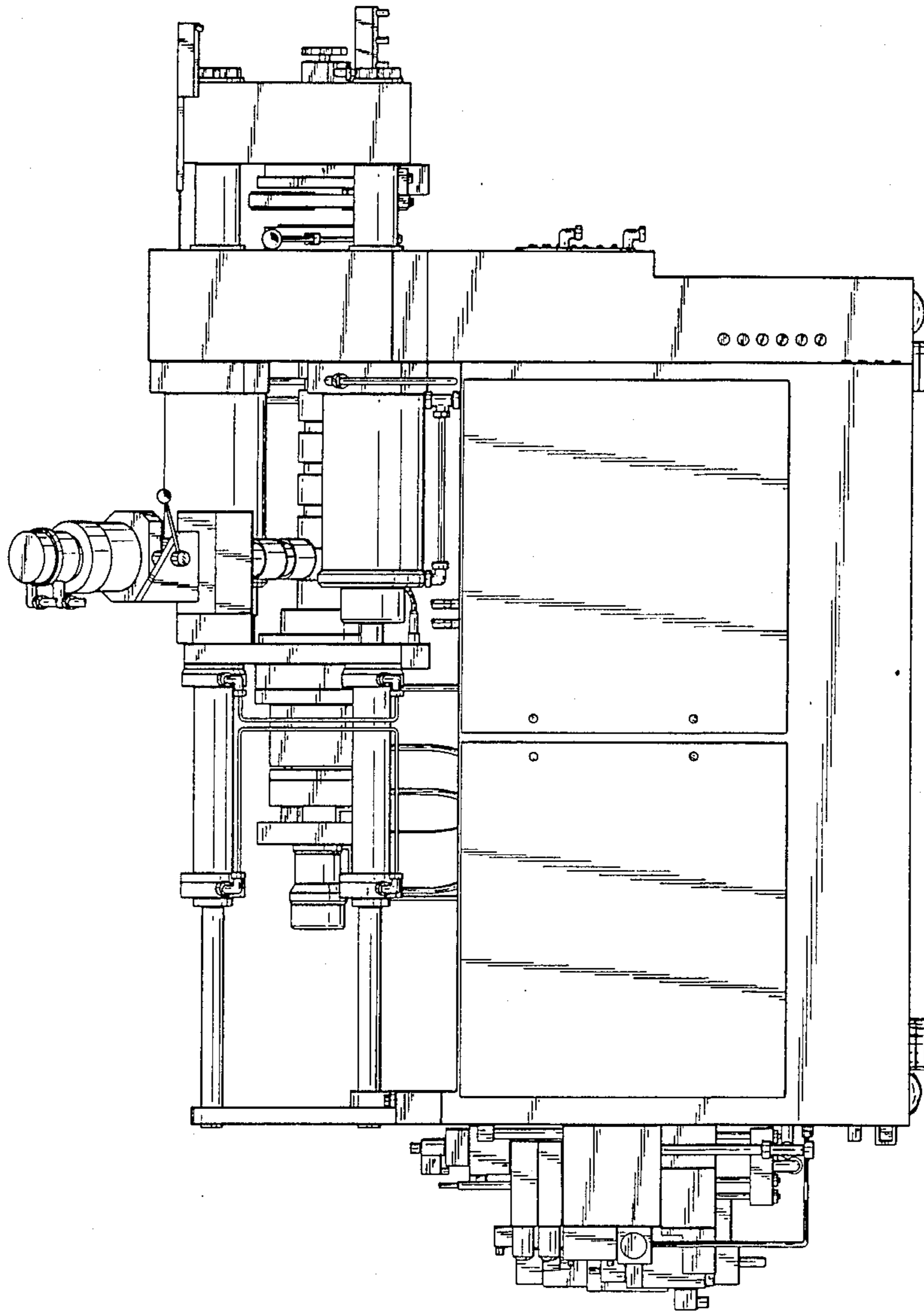

FIG. 1

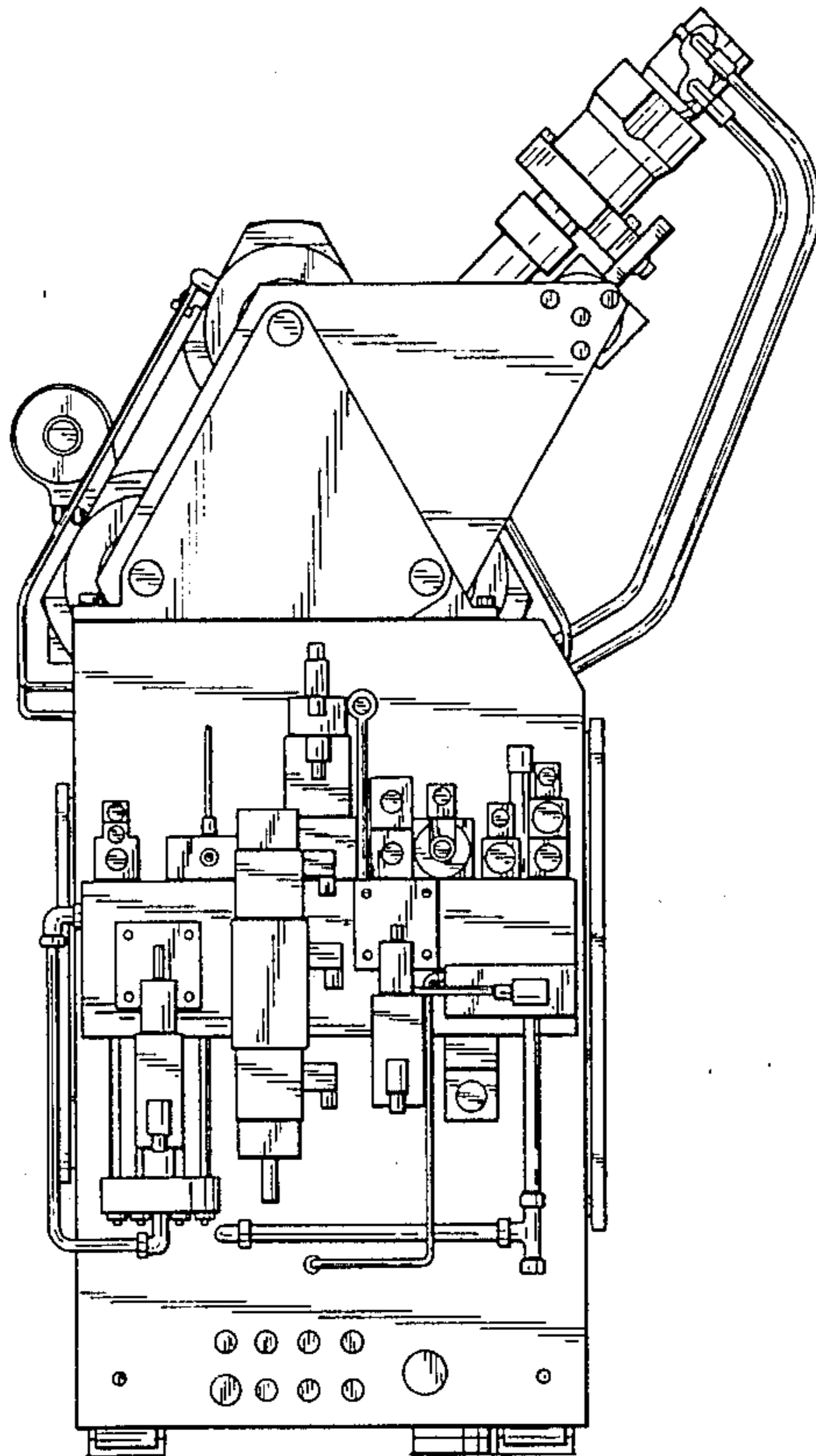

FIG.2

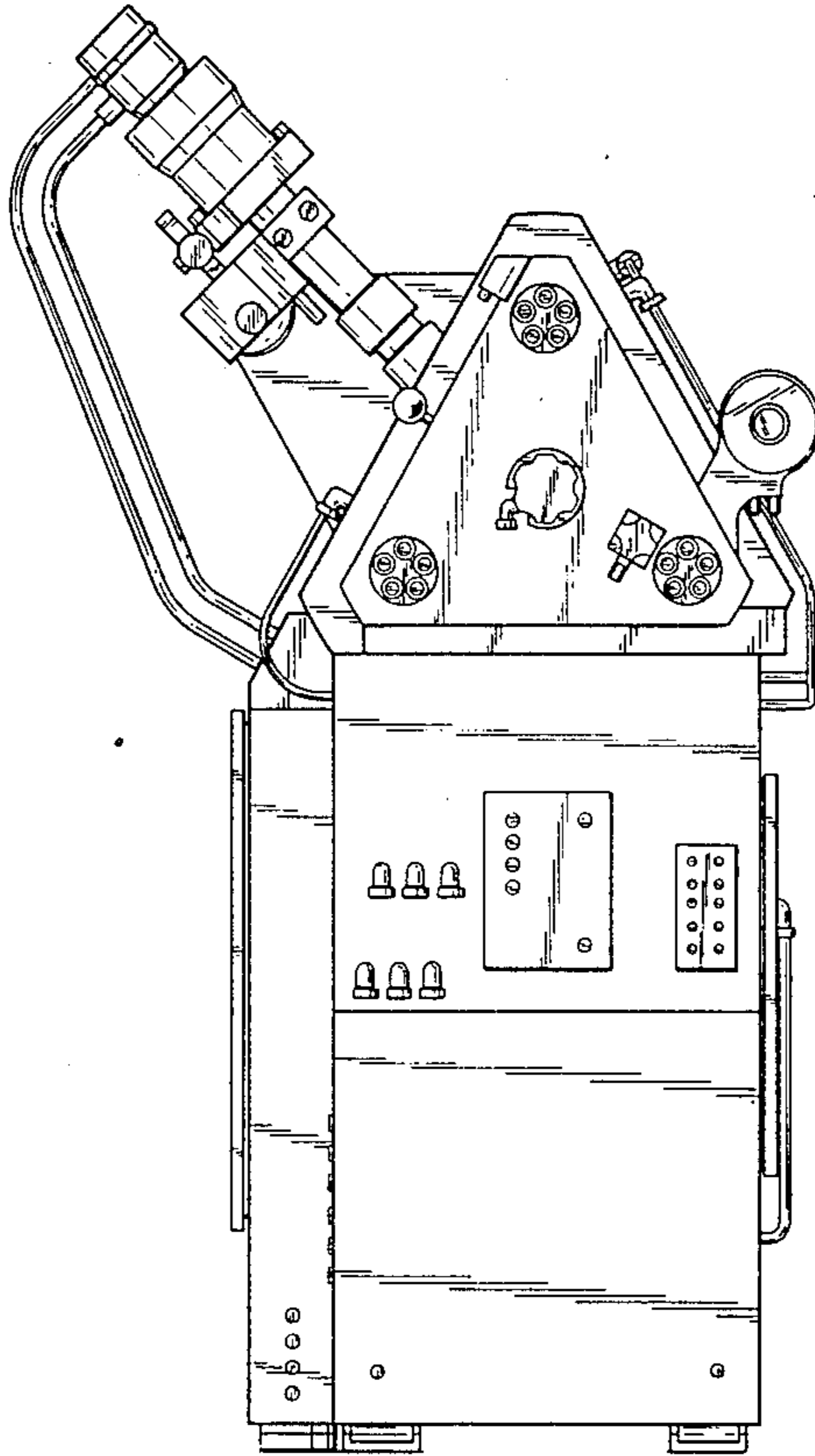

FIG 3

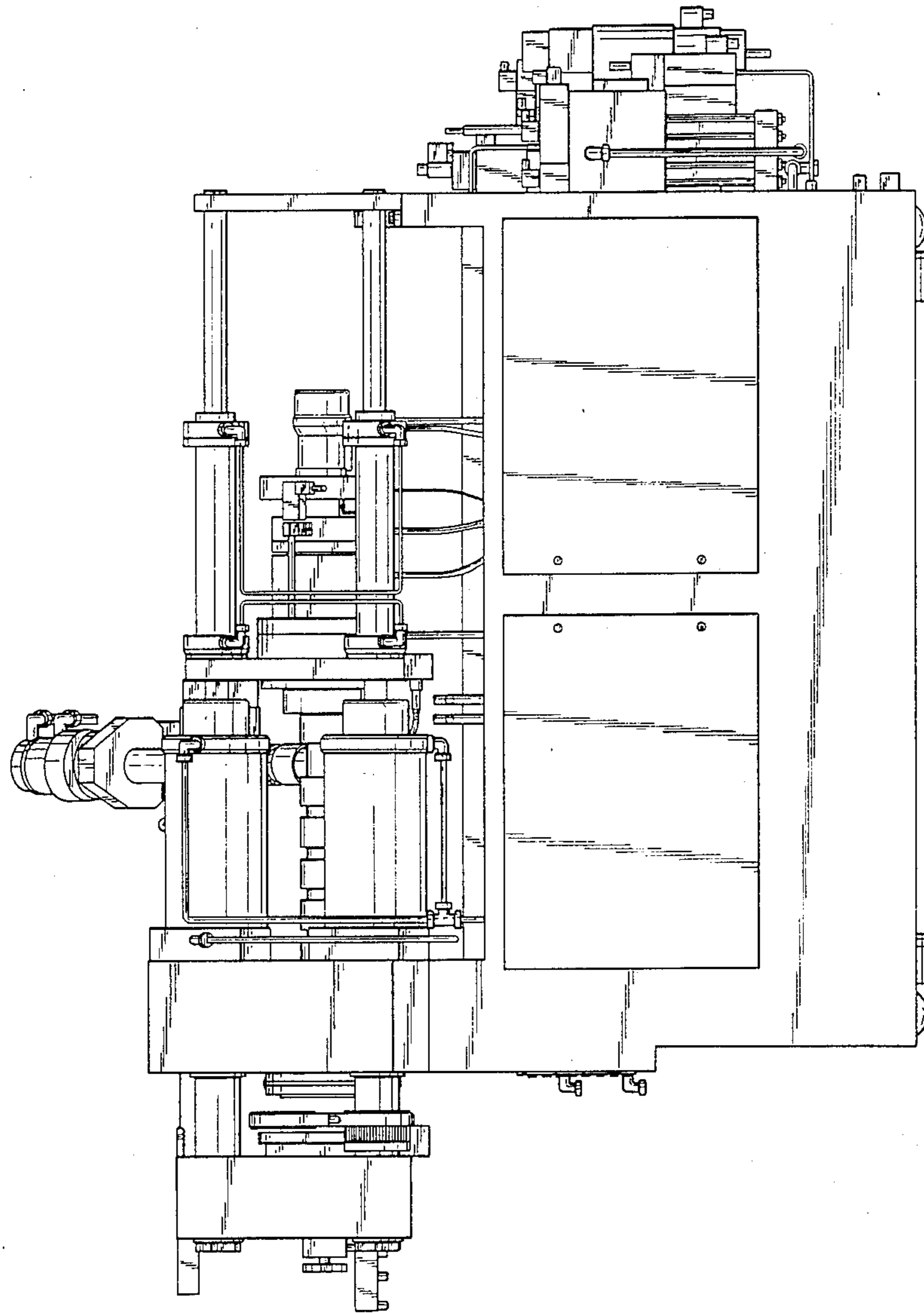

FIG. 4

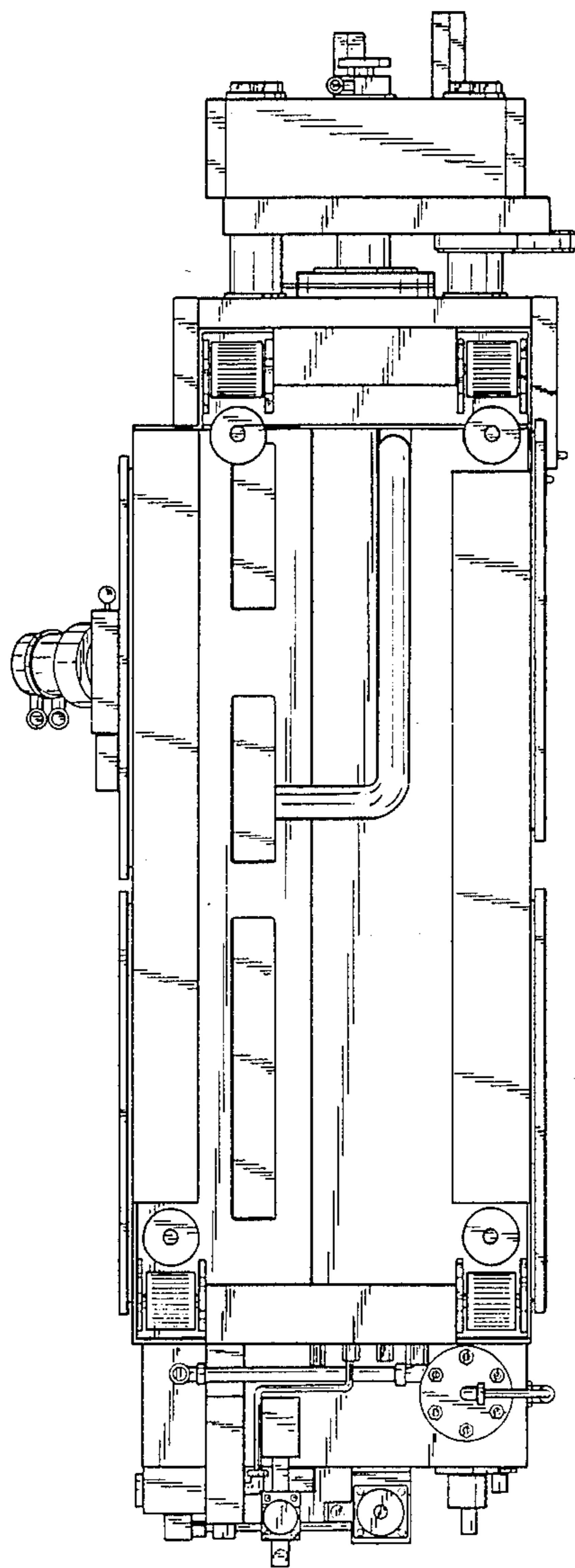

FIG. 5

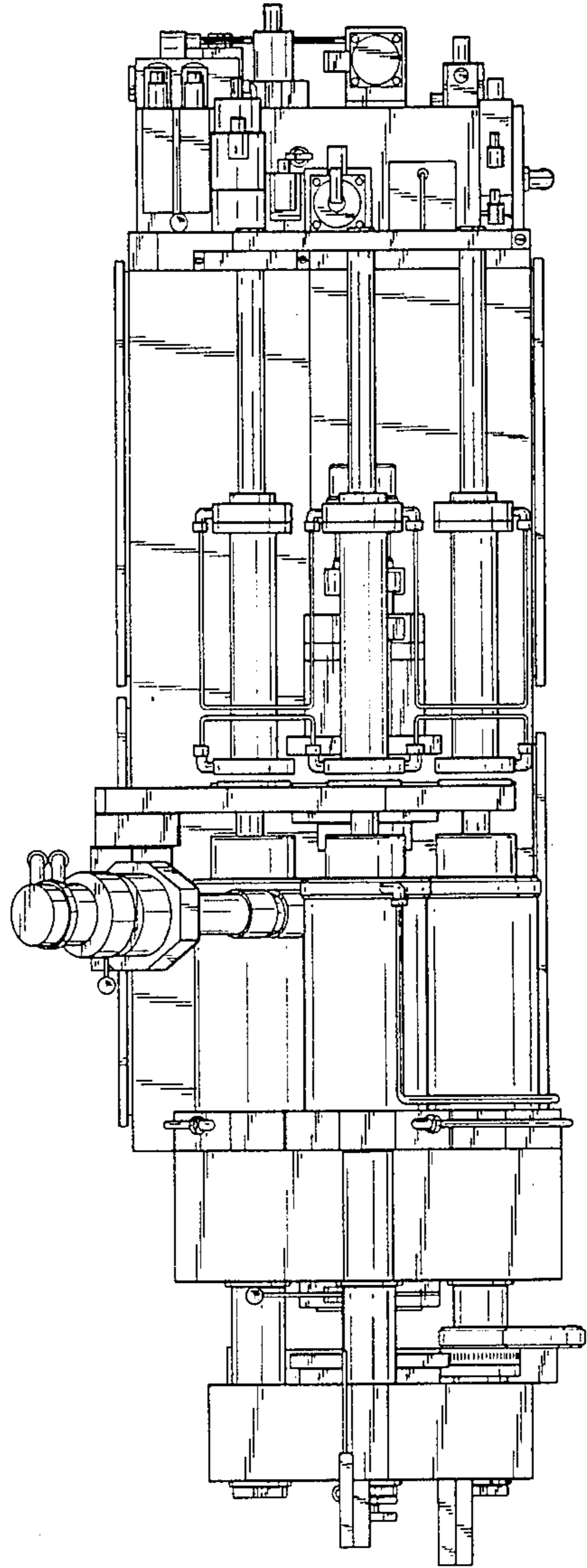

FIG. 6