

[54] COMBINED CONSOLE GEAR LEVER AND  
HANDBRAKE LOCK

[76] Inventor: John P. Preddy, 3 Blackett Street,  
Heathcote, New South Wales 2233,  
Australia

[\*\*] Term: 14 Years

[21] Appl. No.: 877,543

[22] Filed: Jun. 20, 1986

[30] Foreign Application Priority Data

Feb. 14, 1986 [AU] Australia ..... 4195/86

[52] U.S. Cl. .... D8/331

[58] Field of Search ..... D8/330-331,  
D8/339-344; 280/289 L; 70/207-211,  
214-217, 225-227, 237-238, 252-253, 14

[56] References Cited

U.S. PATENT DOCUMENTS

- D. 228,874 10/1973 Thomson et al. .... D8/341
- D. 289,491 4/1987 Johnson ..... D8/330
- 3,245,239 4/1966 Zaidener ..... 70/237 X
- 3,664,164 5/1972 Zaidener ..... 70/14 X

- 4,103,524 8/1978 Mitchell et al. .... 70/209
- 4,304,110 12/1981 Fain ..... 70/209
- 4,660,394 4/1987 Wu ..... 70/238 X

OTHER PUBLICATIONS

Talent Car Radio of 232-246 Railway Parade Kogarah,  
"Lok-A-T-Bar", Rec. Retail, (undated).

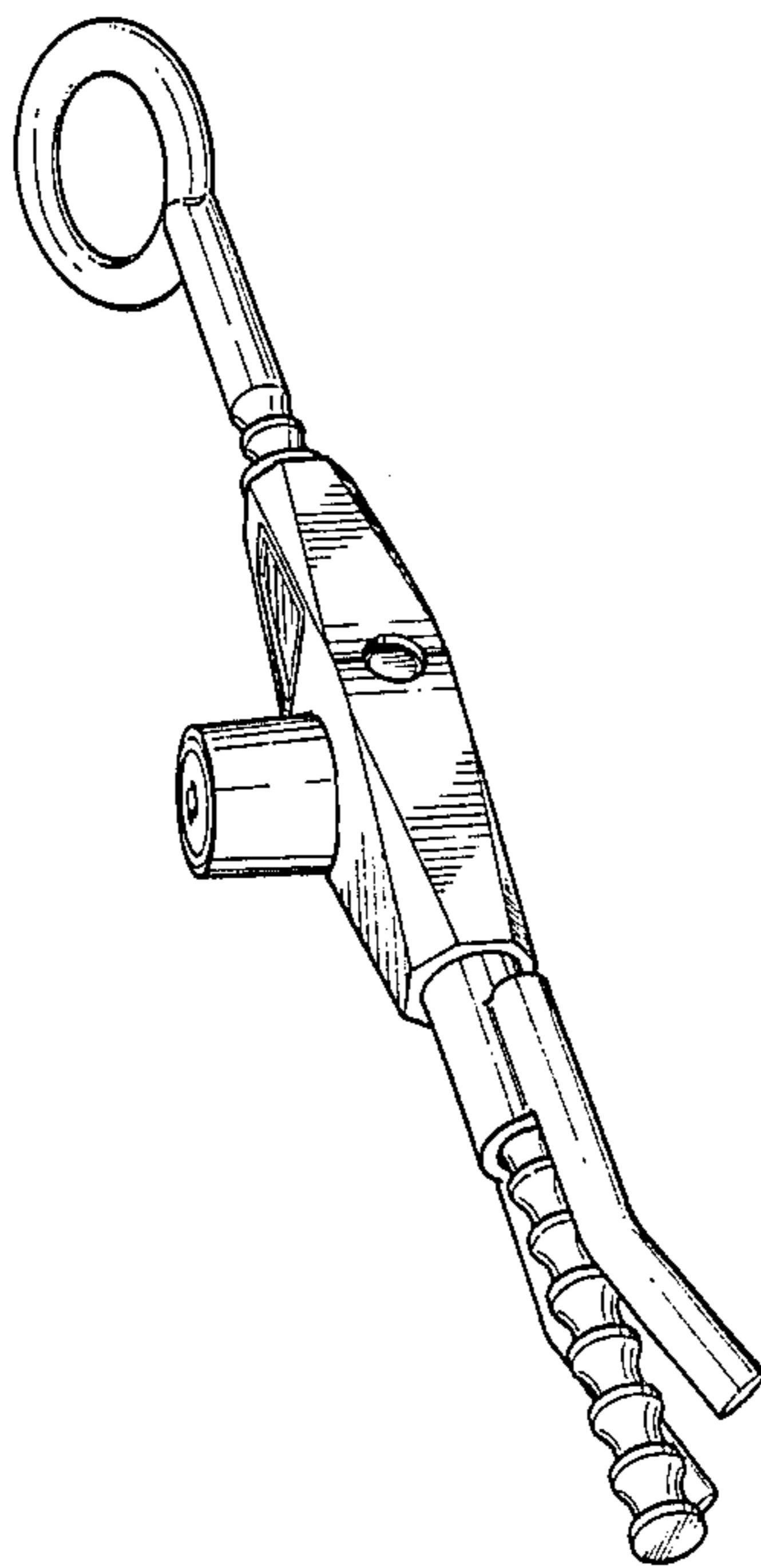
Primary Examiner—Wallace R. Burke  
Assistant Examiner—Brian N. Vinson  
Attorney, Agent, or Firm—Jones, Tullar & Cooper

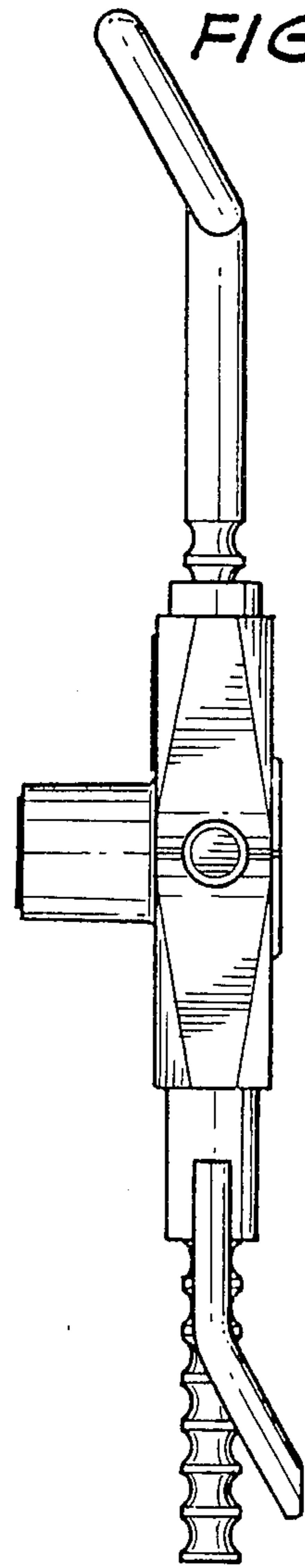
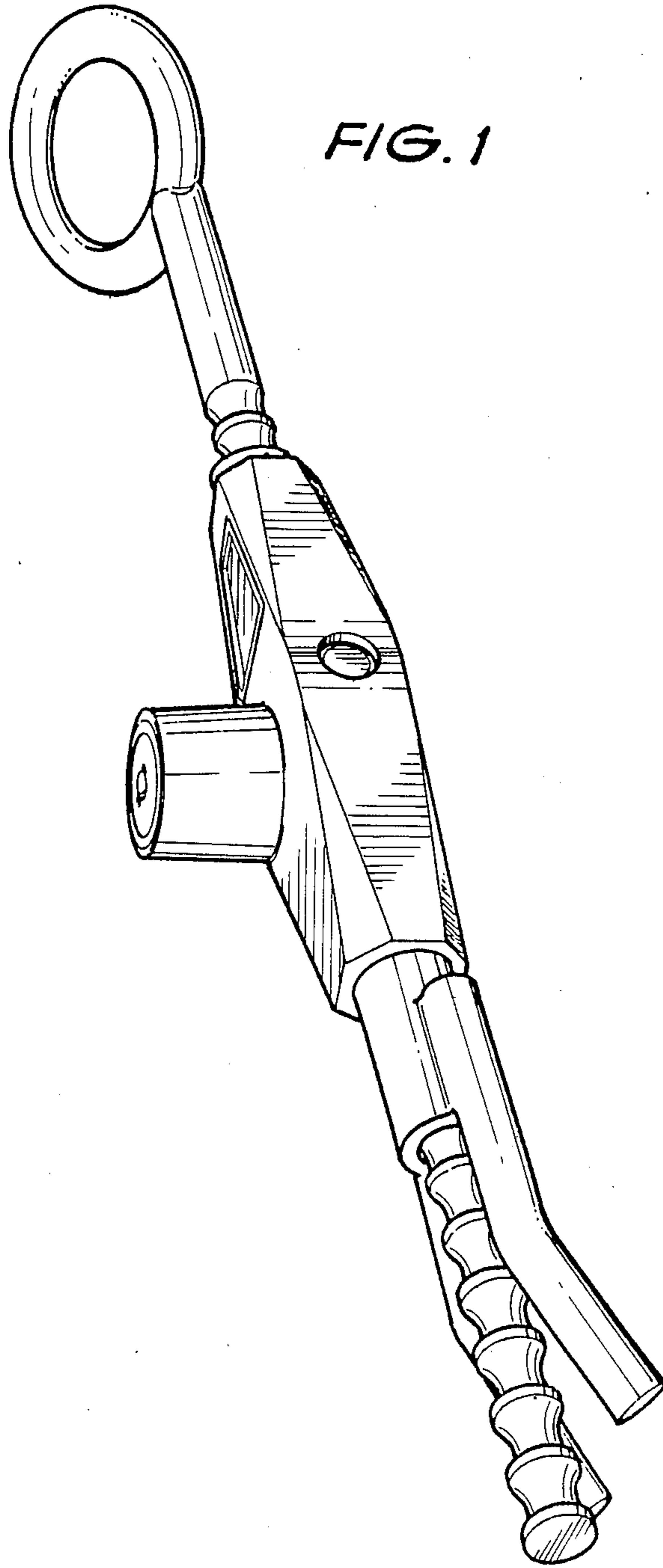
[57] CLAIM

The ornamental design for a combined console gear  
lever and handbrake lock, as shown.

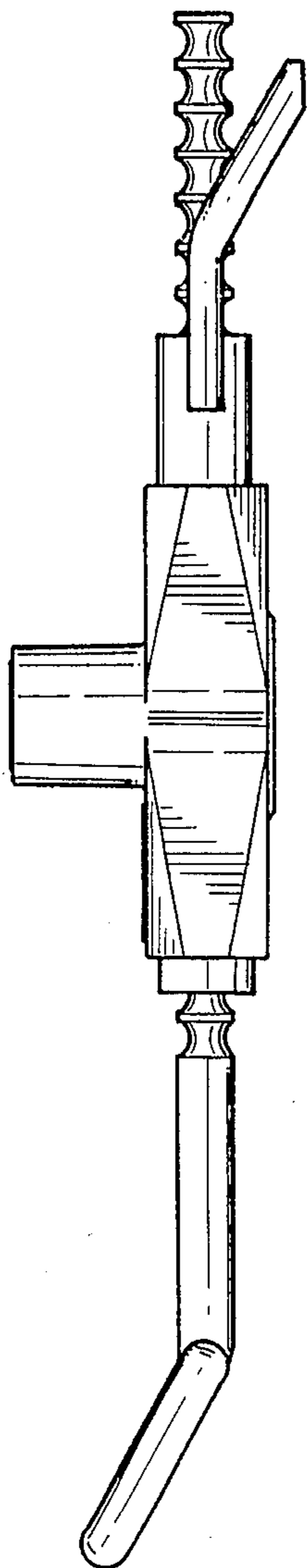
DESCRIPTION

FIG. 1 is a top, front perspective view of a combined  
console gear lever and handbrake lock showing my new  
design;  
FIG. 2 is a reduced right side elevational view thereof;  
FIG. 3 is a reduced left side elevational view thereof;  
FIG. 4 is a reduced rear elevational view thereof;  
FIG. 5 is a reduced front elevational view thereof;  
FIG. 6 is a reduced top plan view thereof; and  
FIG. 7 is a reduced bottom plan view thereof.

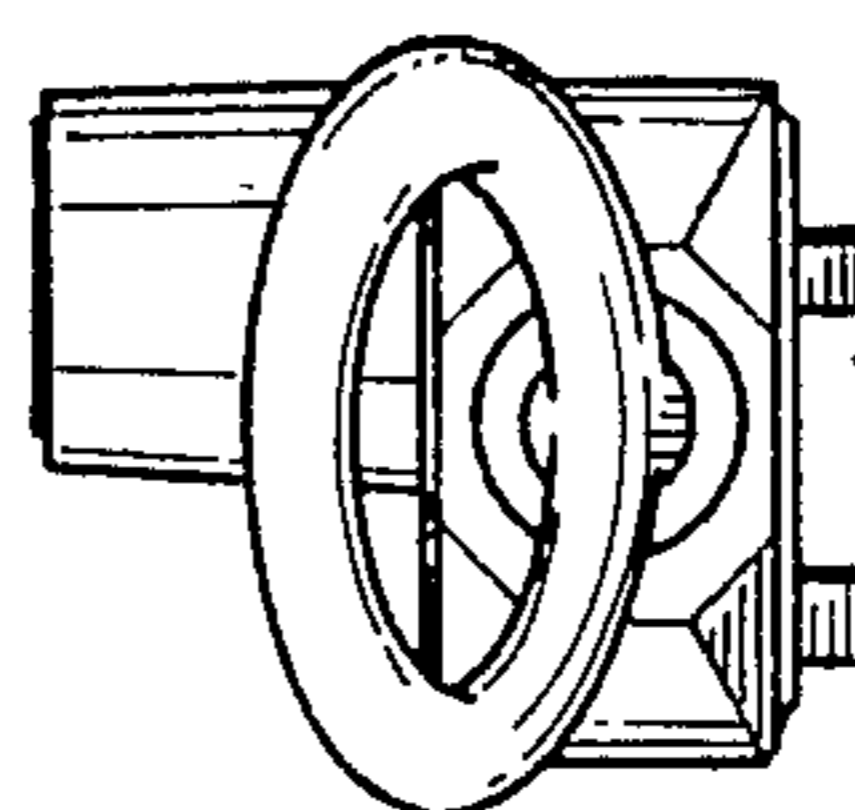




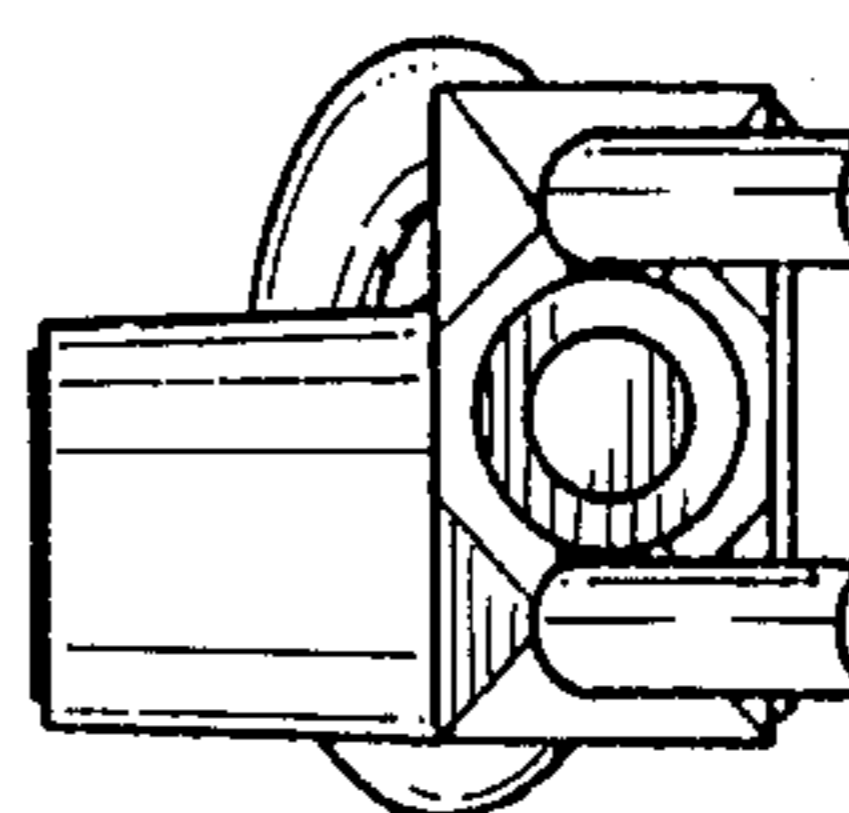
*FIG. 3*



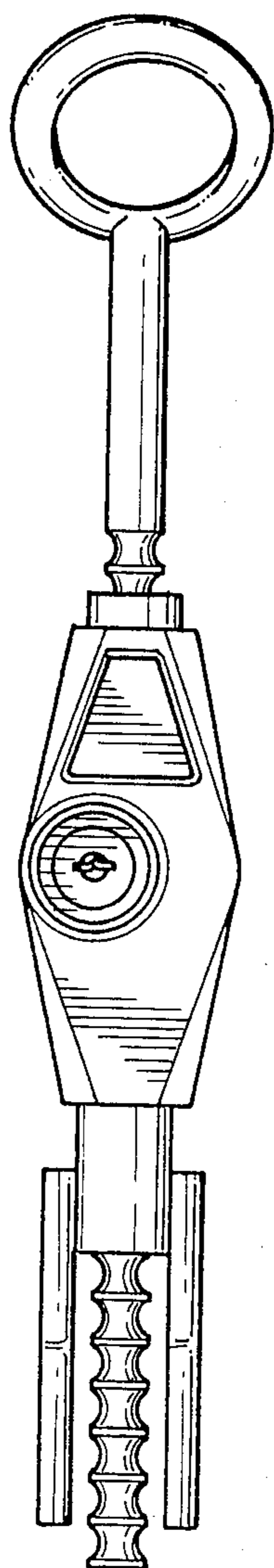
*FIG. 4*



*FIG. 5*



*FIG. 6*



*FIG. 7*

