

[54] LANTERN STOVE ATTACHMENT

[76] Inventor: David Napier, P.O. Box 311, Roark, Ky. 40979

[**] Term: 14 Years

[21] Appl. No.: 651,695

[22] Filed: Sep. 17, 1984

[52] U.S. Cl. D7/407

[58] Field of Search D7/402-403, D7/407-409, 332, 336-337, 347; 126/25 R, 25 A, 25 AA, 25 B, 26-27, 29-30, 38, 39 H, 9 R, 9 B, 258; 99/419, 421 R, 421 HV, 425, 444-450; 248/423

3,133,536 3/1961 Knapp 126/258
3,804,075 4/1974 Rummel 126/258
4,029,079 6/1977 Elder 126/258
4,091,795 5/1978 Wells 126/258

Primary Examiner—Wallace R. Burke
Assistant Examiner—Ruth E. Takemoto
Attorney, Agent, or Firm—King and Schickli

[56] References Cited

U.S. PATENT DOCUMENTS

D. 196,018 8/1963 Palmer et al. D7/337
D. 201,234 5/1965 Busse D7/337
D. 213,652 3/1969 Brancato et al. D7/337
234,153 11/1880 Walterhouse 126/258

[57] CLAIM

The ornamental design for a lantern stove attachment, as shown and described.

DESCRIPTION

FIG. 1 is a top plan view of the lantern stove attachment showing my new design;
FIG. 2 is a front elevational view, the rear elevational view being substantially the same as shown;
FIG. 3 is a right side elevational view, the left side elevational view being substantially the same as shown;
FIG. 4 is a perspective view thereof; and
FIG. 5 is a bottom plan view thereof.

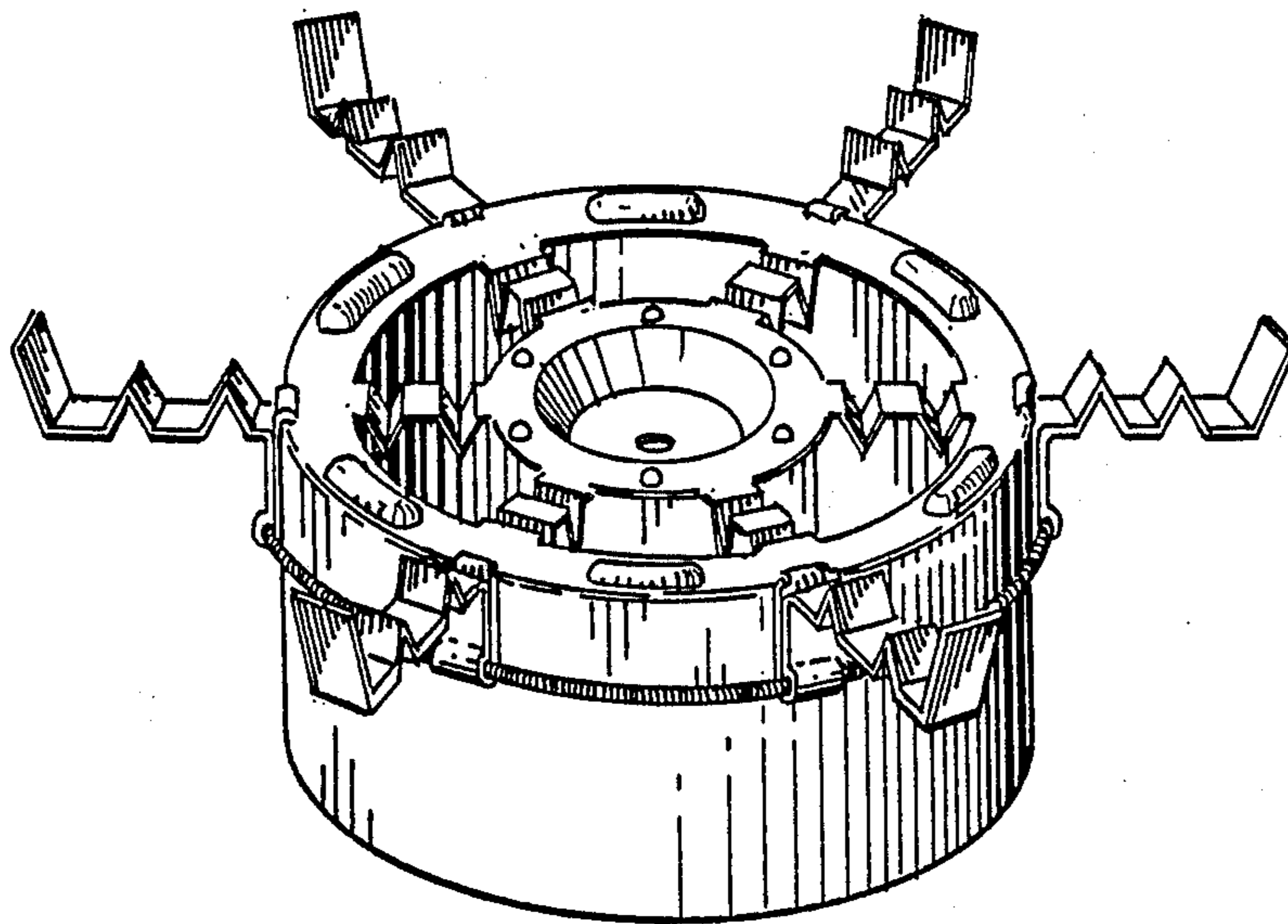

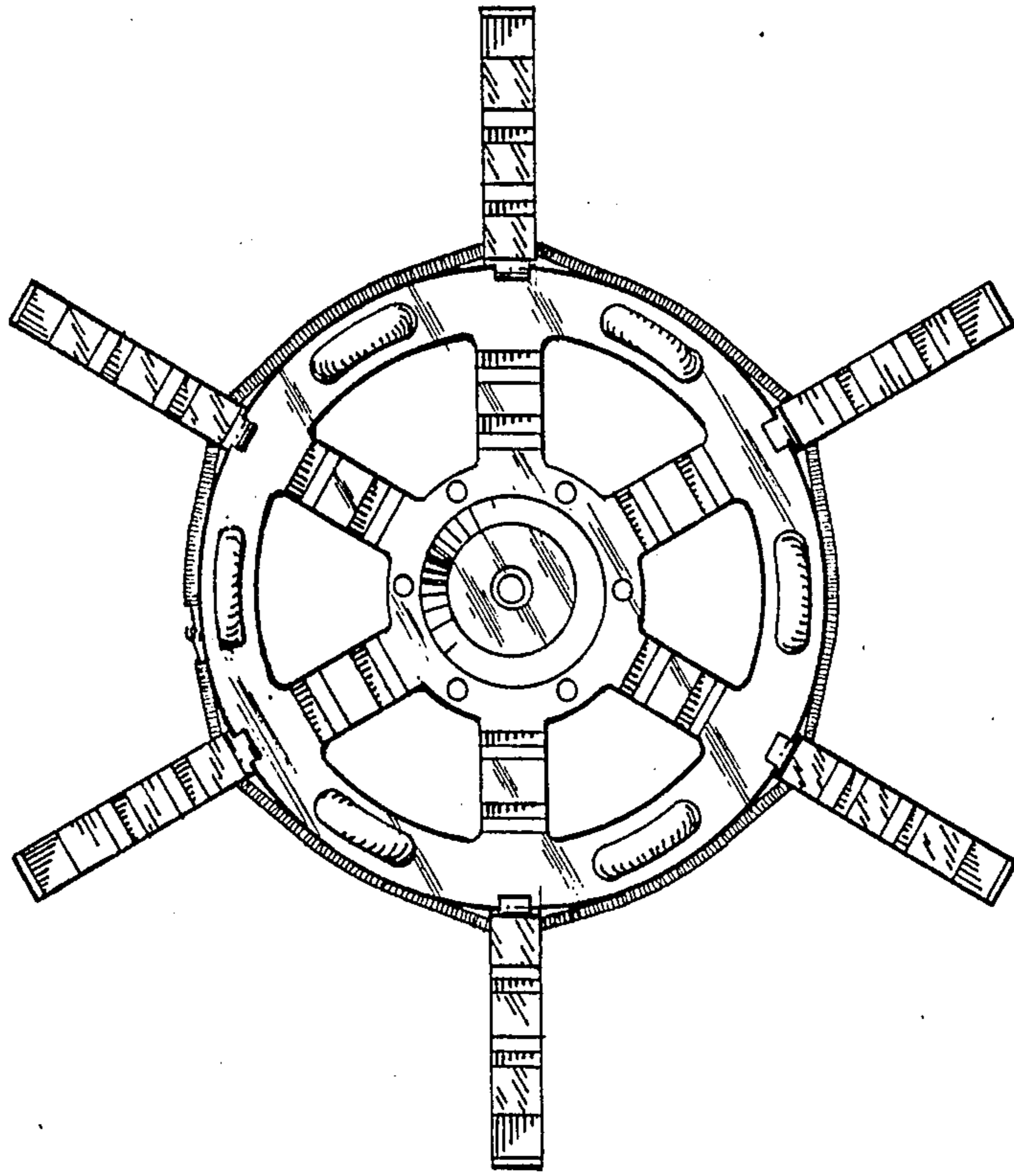

Fig. 1

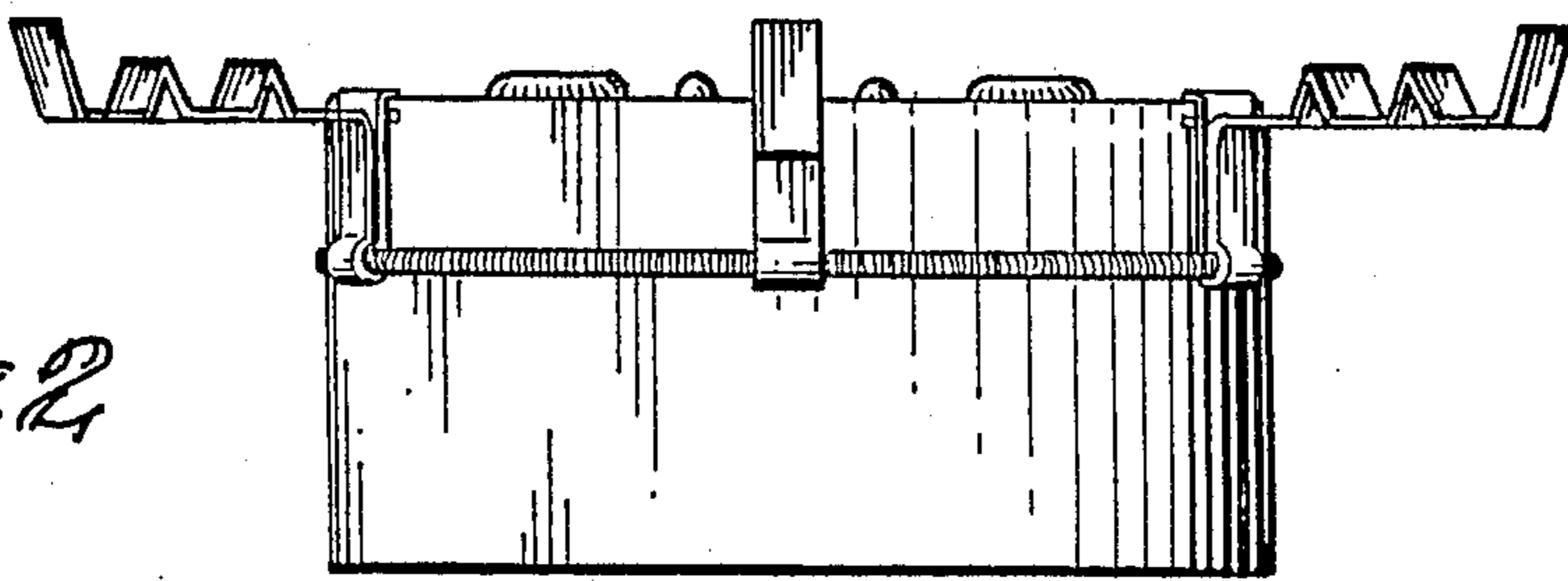

Fig. 2

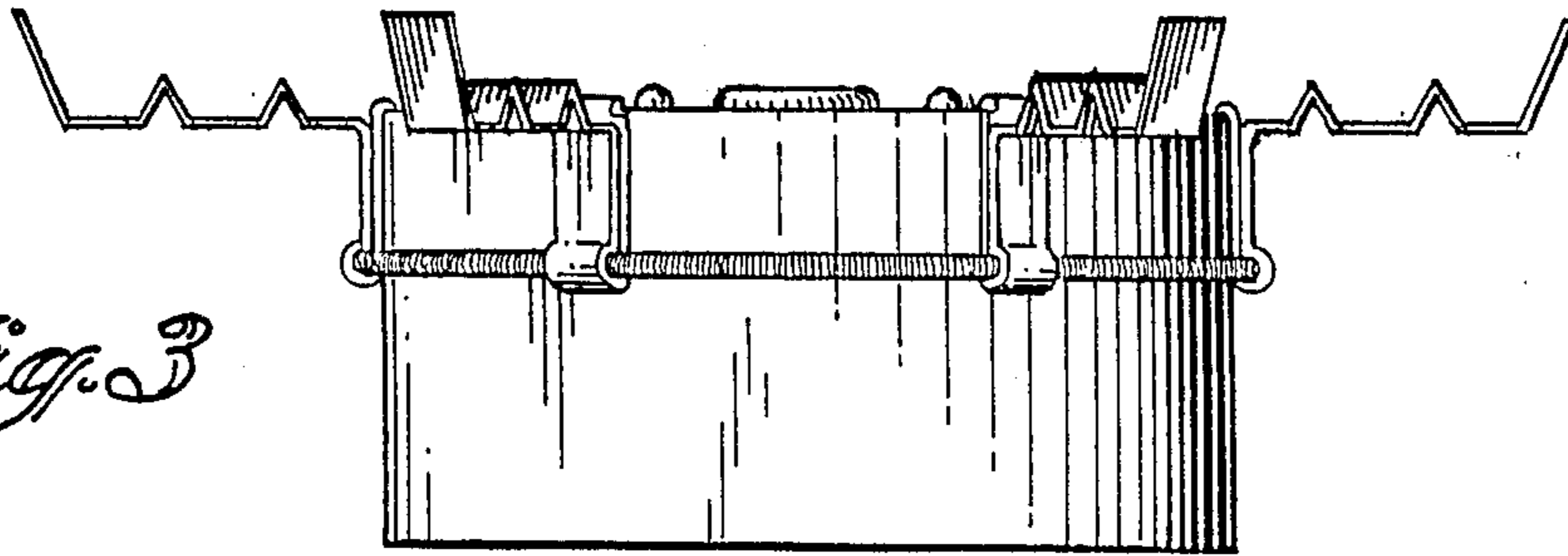

Fig. 3

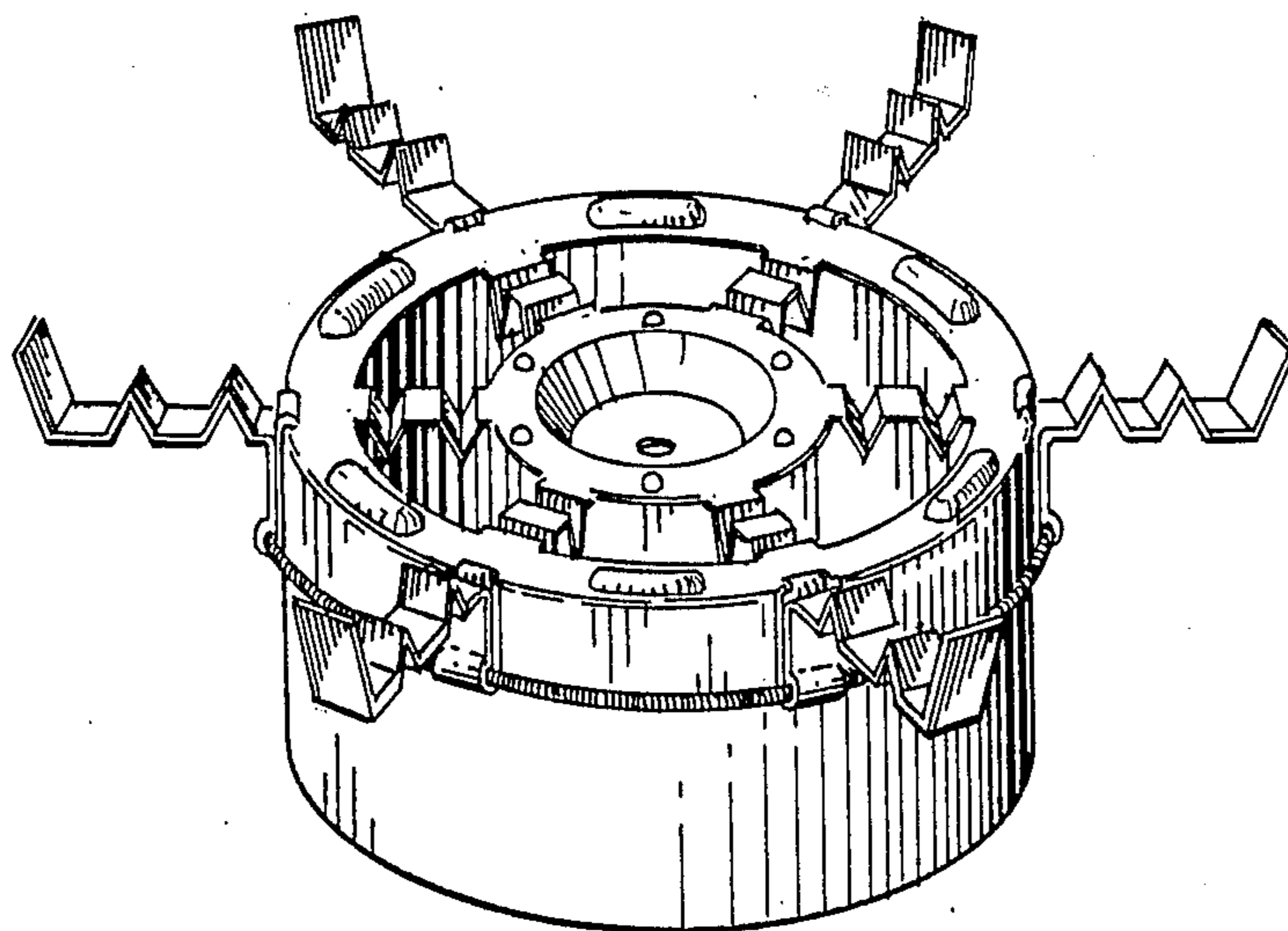

Fig. 4

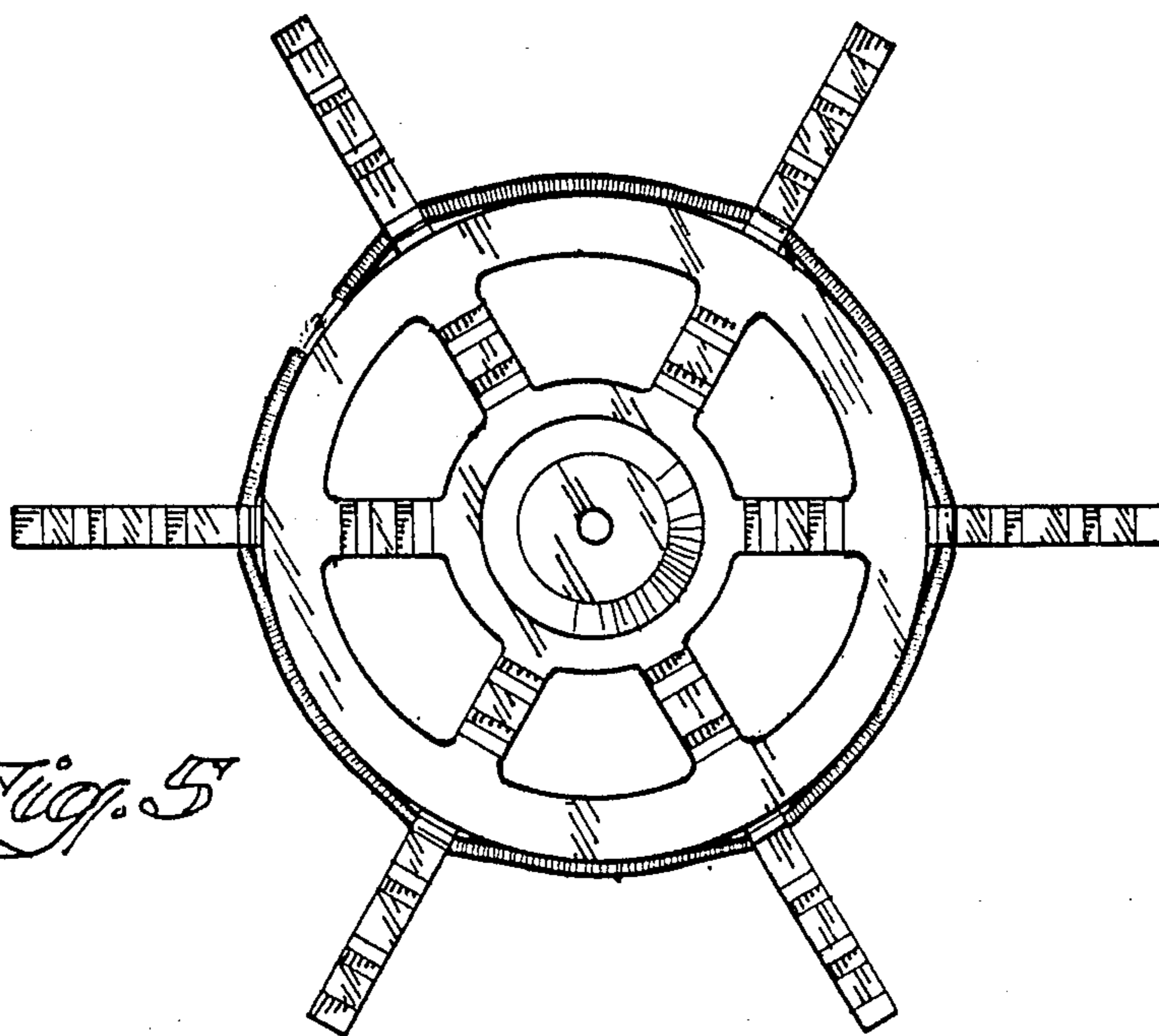

Fig. 5