

[54] ART SUPPLY CAROUSEL

[75] Inventor: Richard P. Nadeau, Frankfort, N.Y.

[73] Assignee: Zorcom Enterprise, Inc., Utica, N.Y.

[\*\*] Term: 14 Years

[21] Appl. No.: 776,595

[22] Filed: Sep. 16, 1985

[52] U.S. Cl. .... D19/77; D3/25; D7/2; D19/85

[58] Field of Search ..... D19/75-92; 206/214; D3/24, 25; 248/70.6; D6/457, 460, 469, 468; D7/2; D9/453

[56] References Cited

U.S. PATENT DOCUMENTS

- D. 131,453 3/1942 Avila ..... D6/457
- D. 159,414 7/1950 Helm ..... D7/2
- D. 191,247 8/1961 McWilliams ..... D19/85
- D. 279,385 6/1985 Lieberman ..... D7/2

- D. 279,950 8/1985 Wan ..... D7/2
- D. 284,235 6/1986 Zinter-Chahin ..... D19/77
- D. 290,053 7/1987 Appel ..... D19/85

Primary Examiner—Charles A. Rademaker  
Attorney, Agent, or Firm—James & Franklin

[57] CLAIM

The ornamental design for an art supply carousel, substantially as shown and described.

DESCRIPTION

FIG. 1 is a top perspective view of a art supply carousel showing my new design;  
 FIG. 2 is a top plan view thereof;  
 FIG. 3 is a bottom perspective view thereof;  
 FIG. 4 is a bottom plan view thereof;  
 FIG. 5 is a front elevational view thereof;  
 FIG. 6 is a side elevational view thereof; and  
 FIG. 7 is a rear elevational view thereof; and  
 FIG. 8 is another perspective view thereof showing the design in an exploded condition.

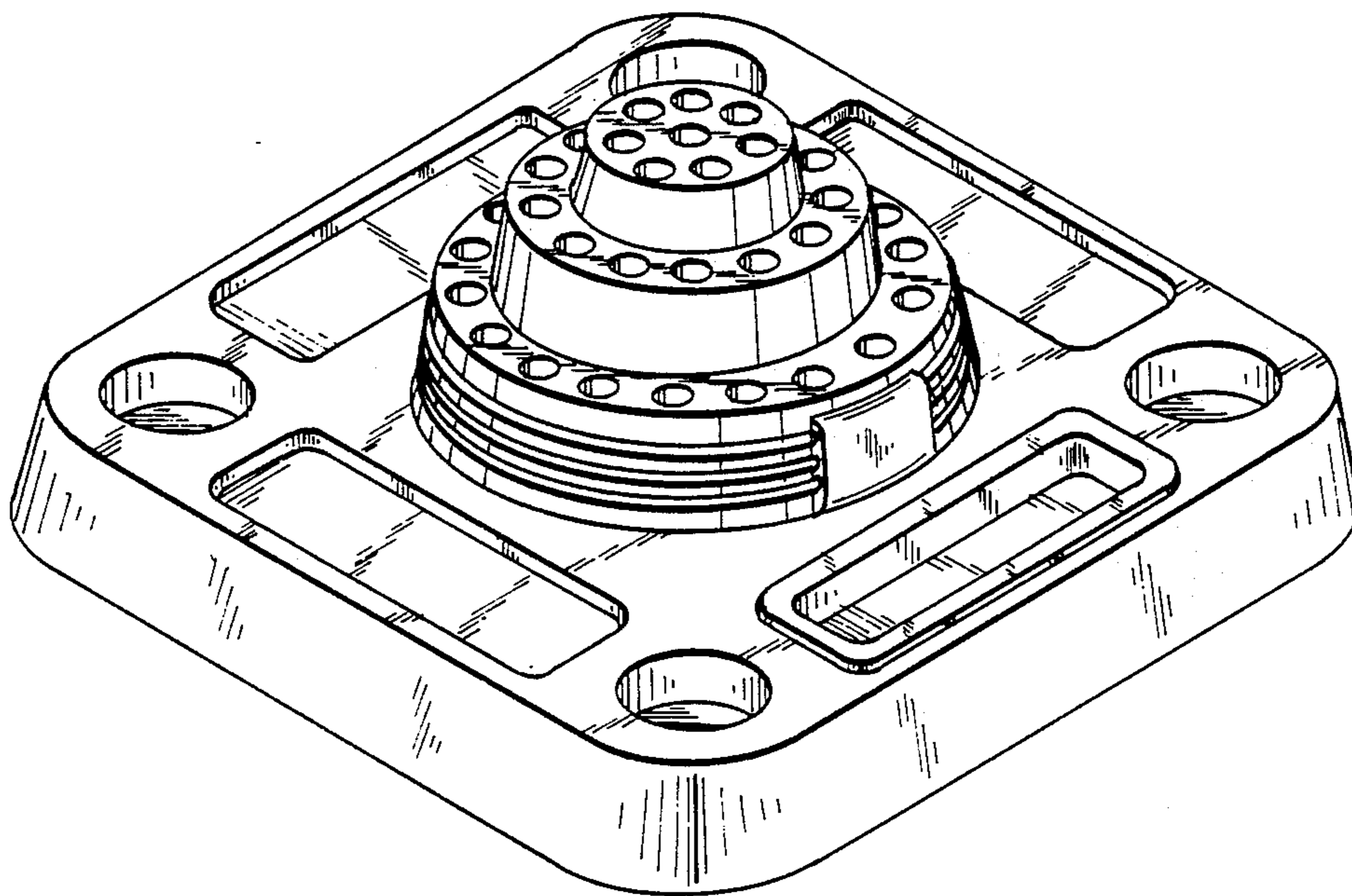

FIG. 1

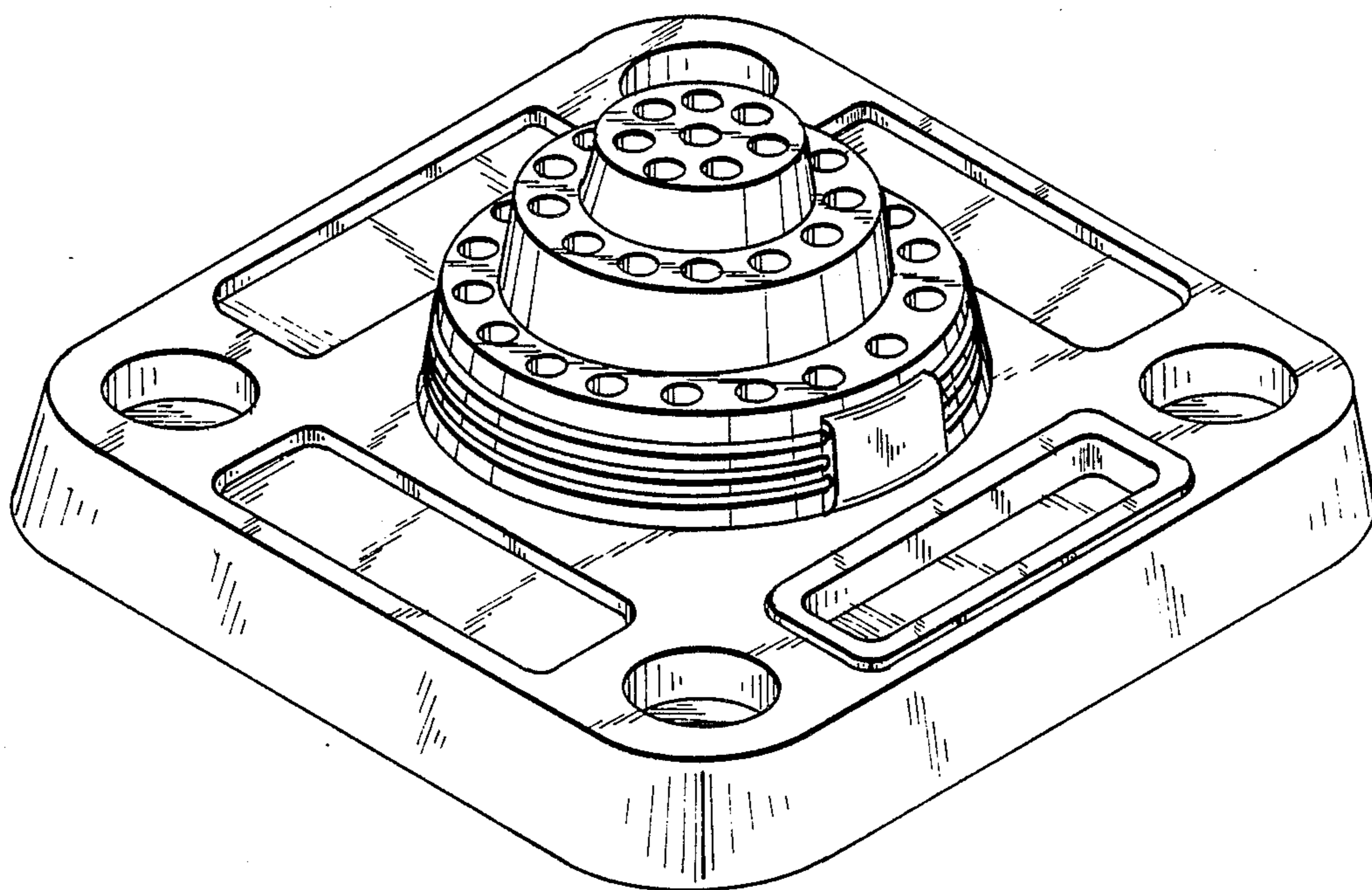

FIG. 2

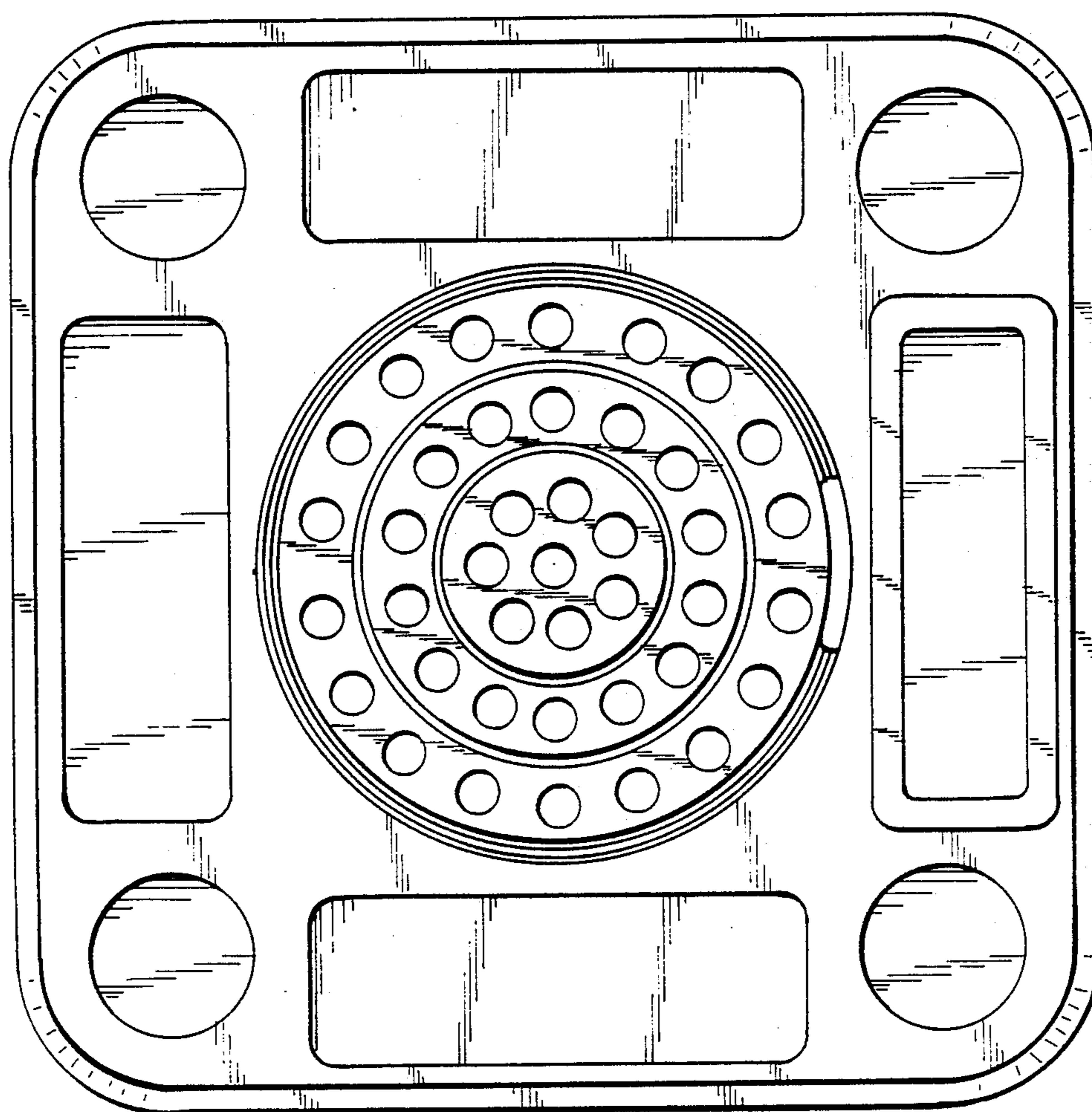

FIG. 3

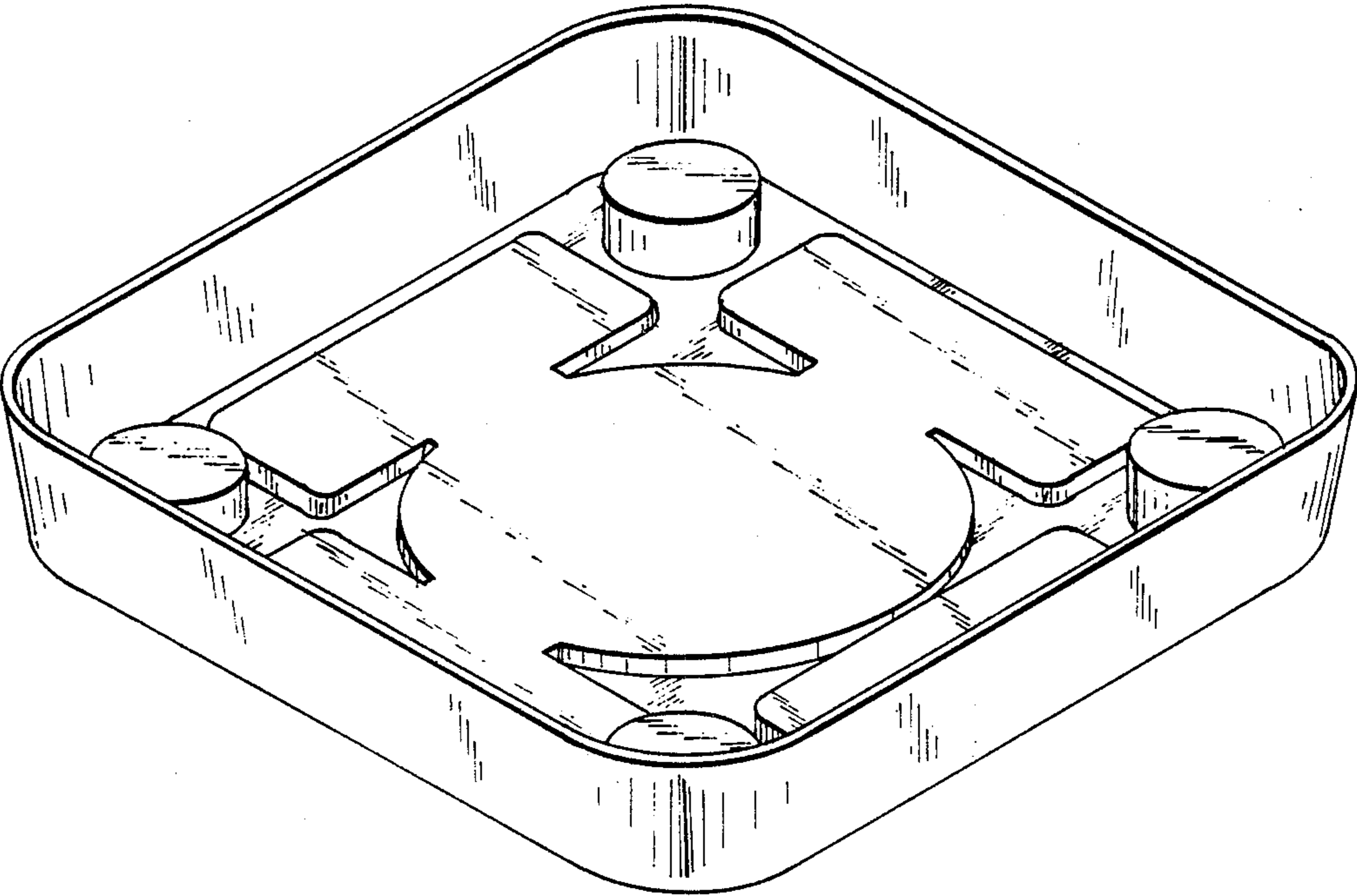

FIG. 4

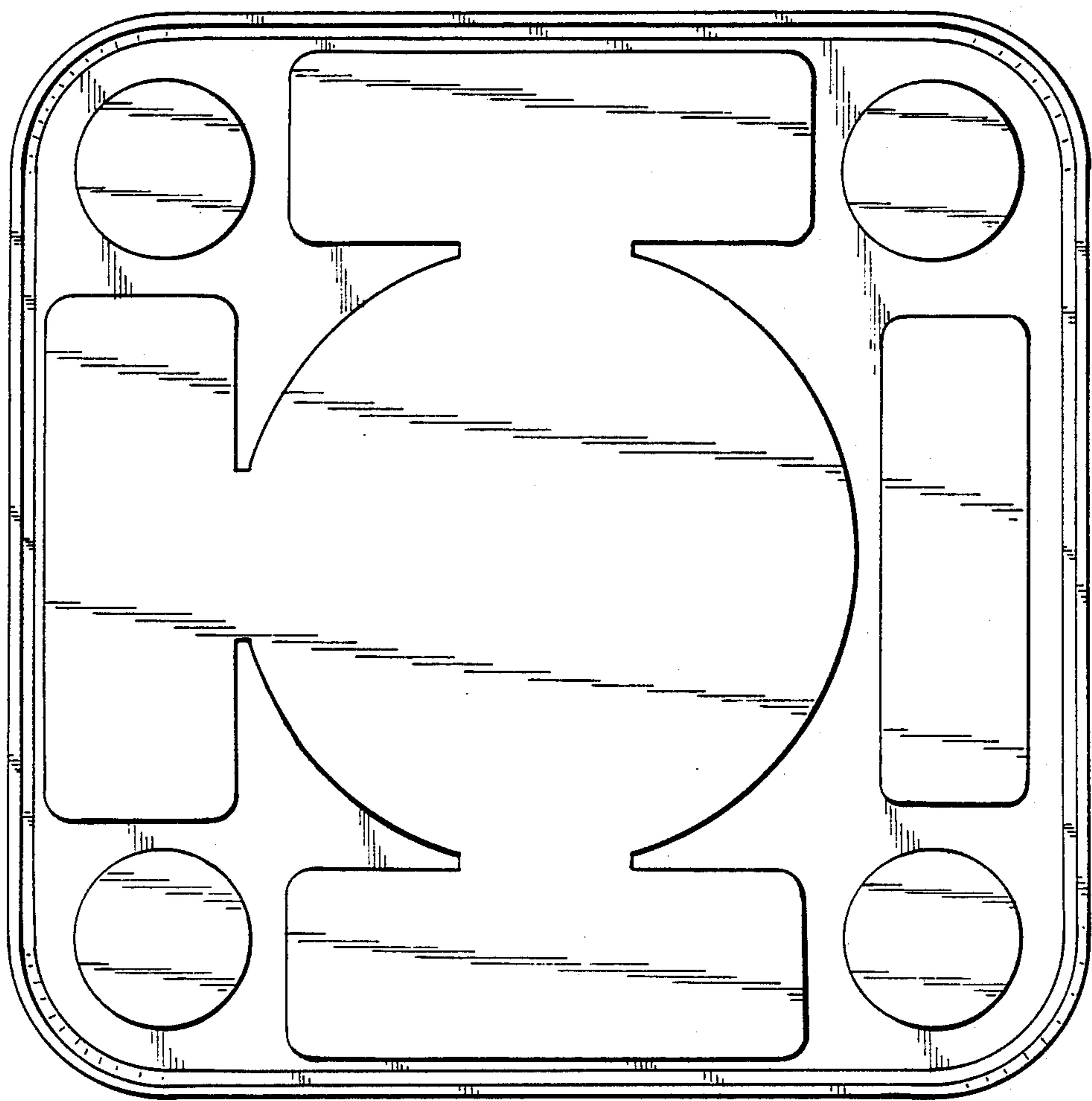

FIG. 5

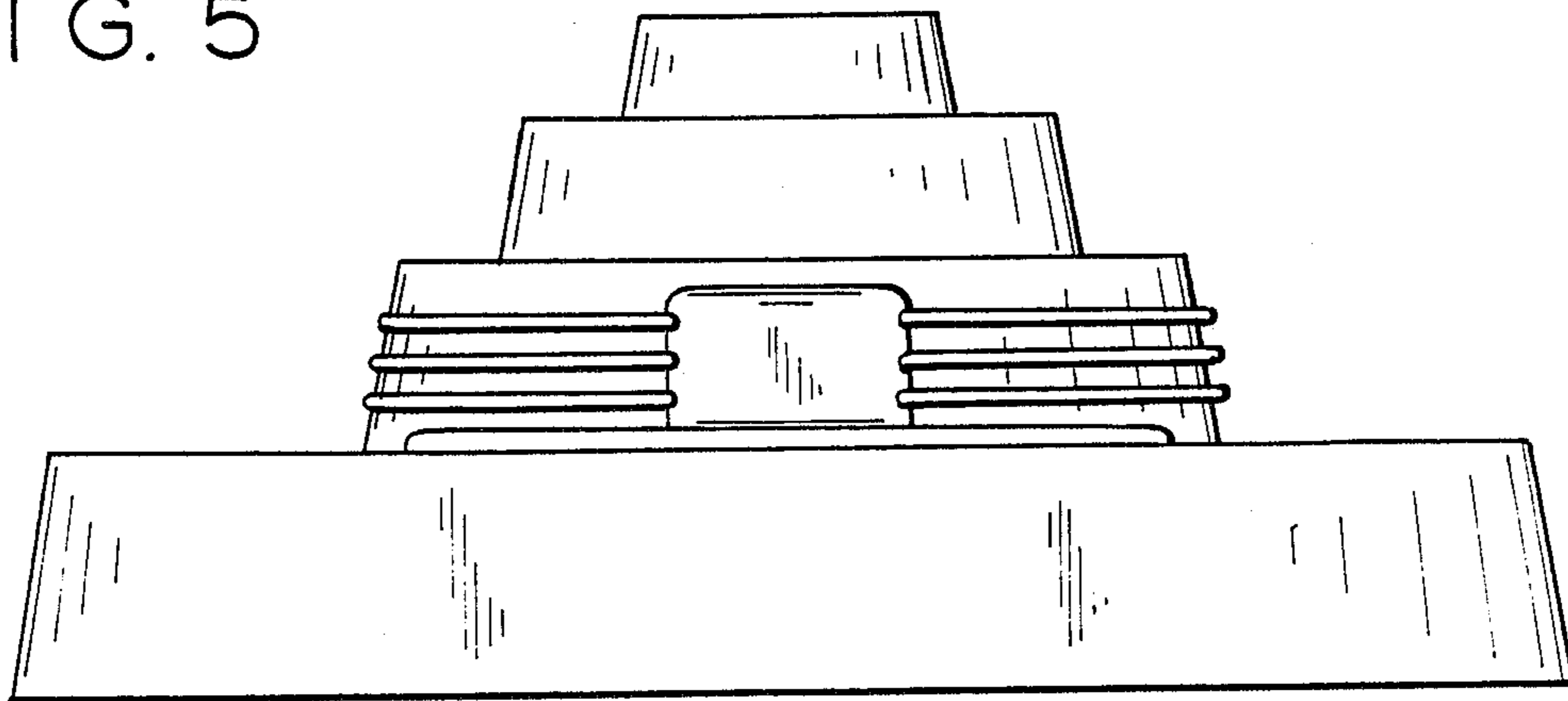

FIG. 6

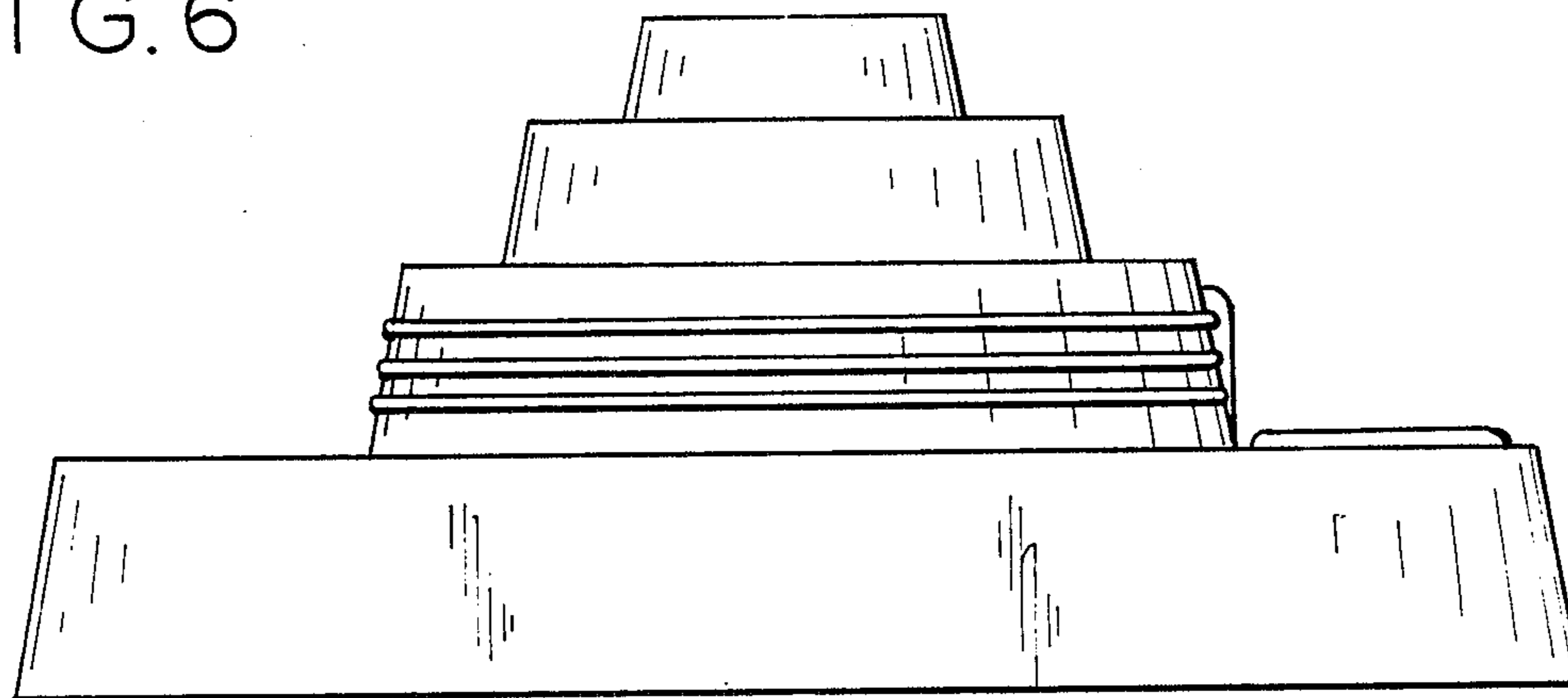

FIG. 7

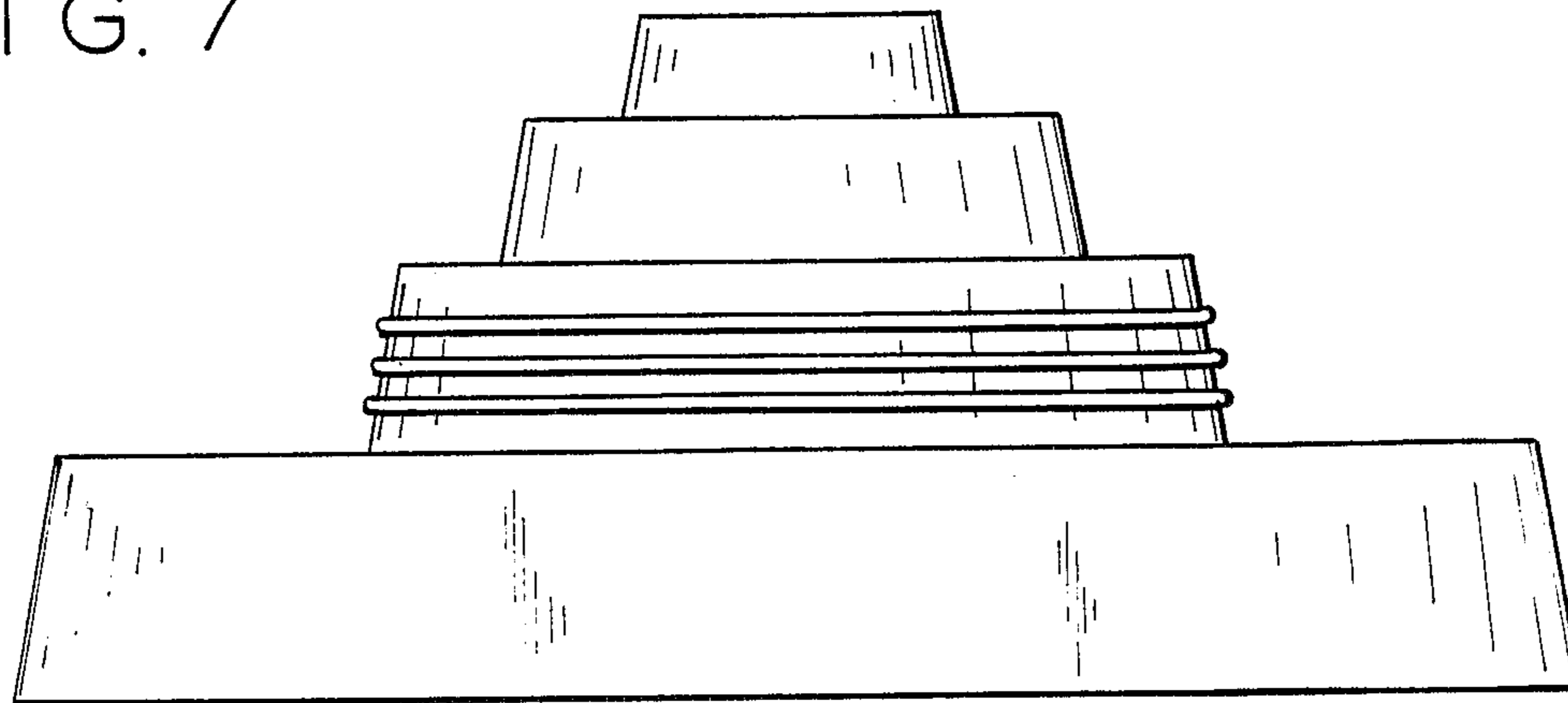

FIG. 8

