

[54] ENGINE HOUSING FOR A CLEARING SAW

[75] Inventor: Lars-Göran Rosenblad, Gränna, Sweden

[73] Assignee: Aktiebolaget Electrolux, Sweden

[\*\*] Term: 14 Years

[21] Appl. No.: 806,857

[22] Filed: Nov. 27, 1985

[30] Foreign Application Priority Data

May 29, 1985 [SE] Sweden ..... 85-1394

[52] U.S. Cl. .... D15/1

[58] Field of Search ..... D15/1, 3, 5, 10, 12; D21/125; D8/1, 7, 8; 56/12.7; 30/216, 264, 276, 347, DIG. 5

[56] References Cited

U.S. PATENT DOCUMENTS

D. 252,130 6/1979 Hoff ..... D8/8

D. 260,394 8/1981 Tuggle ..... D8/8 X  
3,579,827 5/1971 Grahn ..... 30/216 X  
4,236,310 12/1980 Müller ..... 30/276  
4,286,675 9/1981 Tuggle ..... 30/276 X

Primary Examiner—B. J. Bullock  
Assistant Examiner—Brian N. Vinson  
Attorney, Agent, or Firm—Alfred E. Miller

[57] CLAIM

The ornamental design for an engine housing for a clearing saw, as shown and described.

DESCRIPTION

FIG. 1 is a right side elevational view of an engine housing for a clearing saw showing my new design; FIG. 2 is a top plan view thereof; FIG. 3 is a top, right side and rear end perspective view thereof; FIG. 4 is a left side elevational view thereof; FIG. 5 is a bottom plan view thereof; and, FIG. 6 is a front end elevational view thereof.

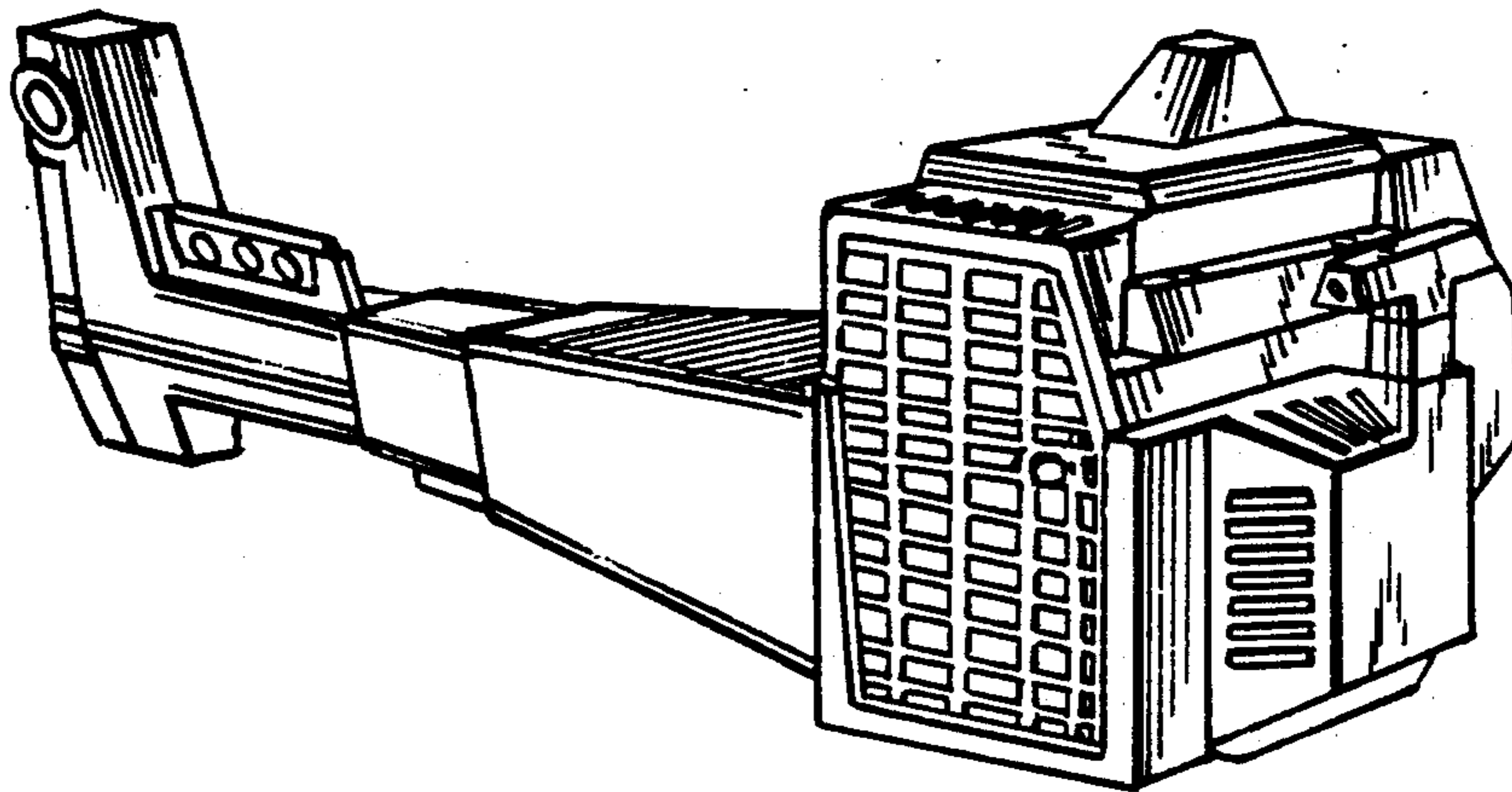

FIG. 1

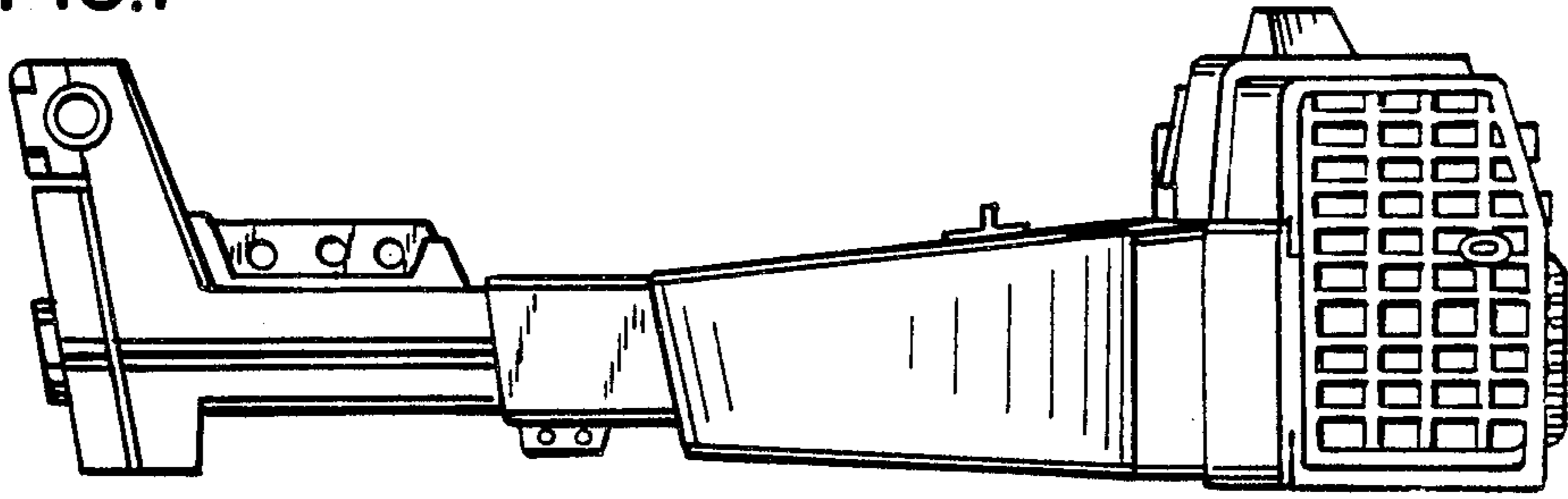

FIG. 2

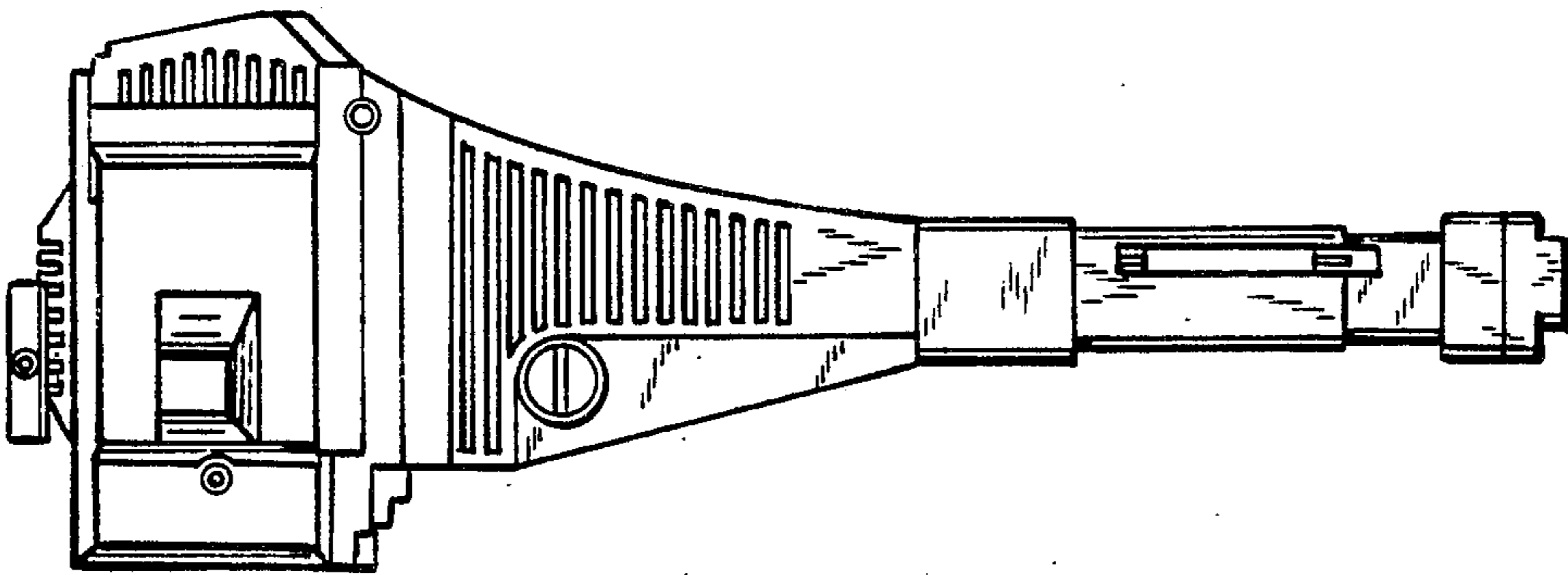

FIG. 3

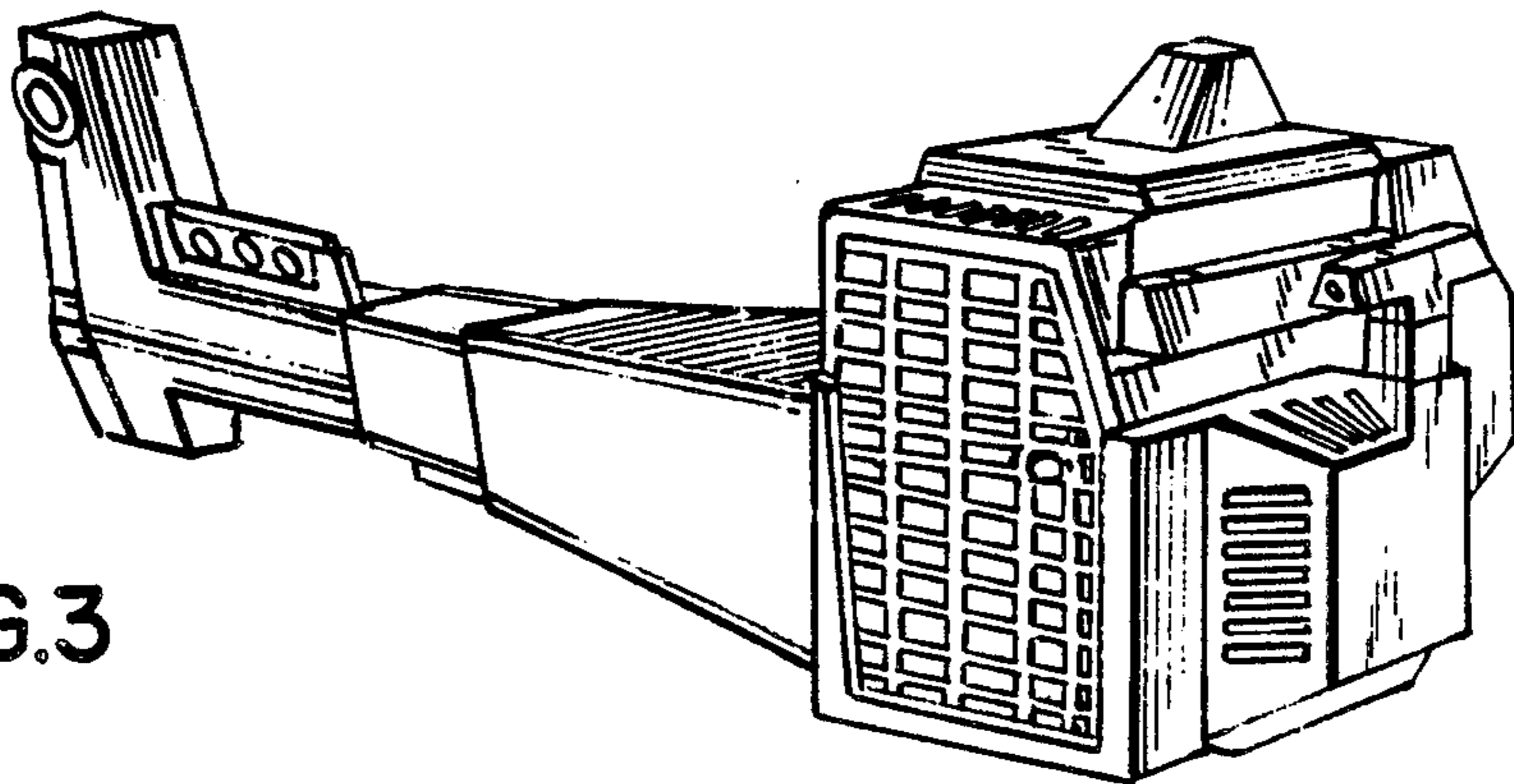

FIG. 4

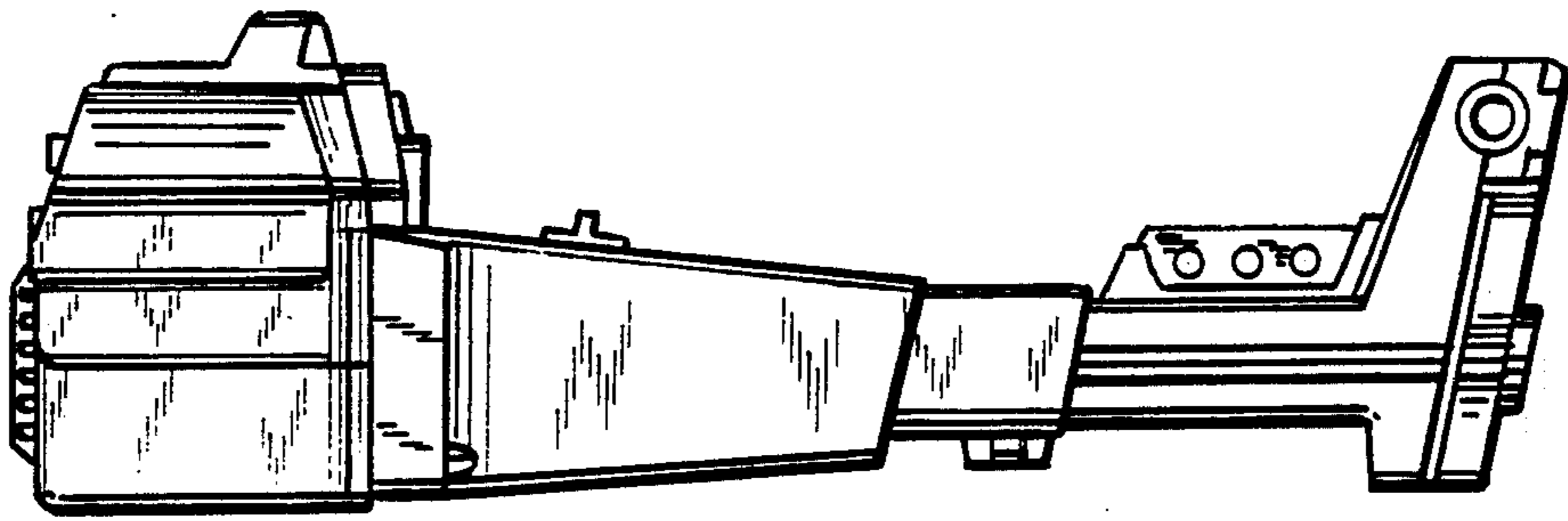

FIG. 5

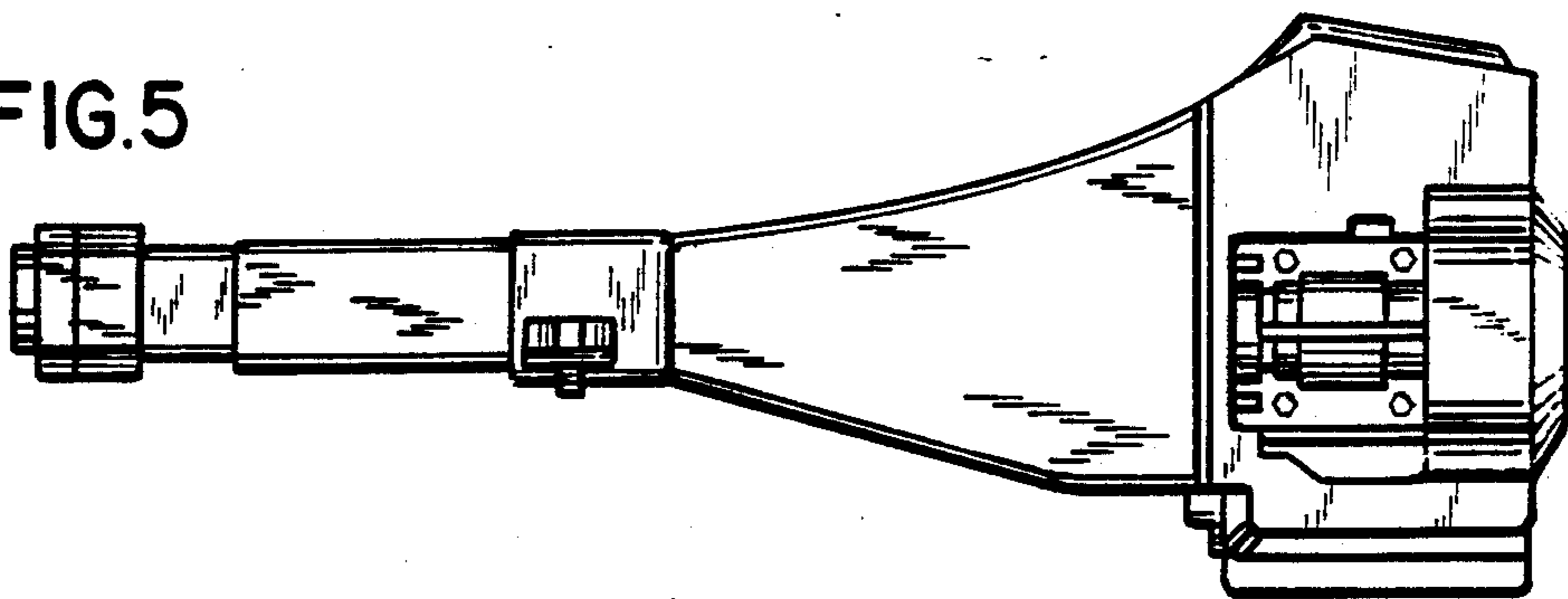

FIG. 6

