

[54] MOTORCYCLE

D. 286,519 11/1986 Komuro et al. .... D12/110

[75] Inventors: Toshiyuki Yamada, Saitama; Makoto Kitagawa, Tokyo; Toshio Kurihara, Saitama, all of Japan

[73] Assignee: Honda Giken Kogyo Kabushiki Kaisha, Tokyo, Japan

[\*\*] Term: 14 Years

[21] Appl. No.: 780,561

[22] Filed: Sep. 26, 1985

[30] Foreign Application Priority Data

Apr. 30, 1985 [JP] Japan ..... 60-17805

[52] U.S. Cl. .... D12/110

[58] Field of Search ..... D12/110; 180/219

[56] References Cited

U.S. PATENT DOCUMENTS

D. 227,799 7/1973 Taylor ..... D48/32 R

D. 281,875 12/1985 Stahel ..... D12/182

OTHER PUBLICATIONS

Cycle World, 4/84, p. 77. 1984 Honda Gold Wing Aspencade Motorcycle, bottom of page.

Cycle World, Jun. 1986, article "The Supertourers" pp. 32-44.

Primary Examiner—James M. Gandy  
Attorney, Agent, or Firm—Lyon & Lyon

[57] CLAIM

The ornamental design for a motorcycle, as shown.

DESCRIPTION

FIG. 1 is a top plan view of a motorcycle showing our new design;

FIG. 2 is a front perspective view thereof;

FIG. 3 is a side perspective view of the right side thereof;

FIG. 4 is a side perspective view of the left side thereof;

FIG. 5 is a back perspective view thereof;

FIG. 6 is an oblique perspective view principally illustrating the left side thereof.

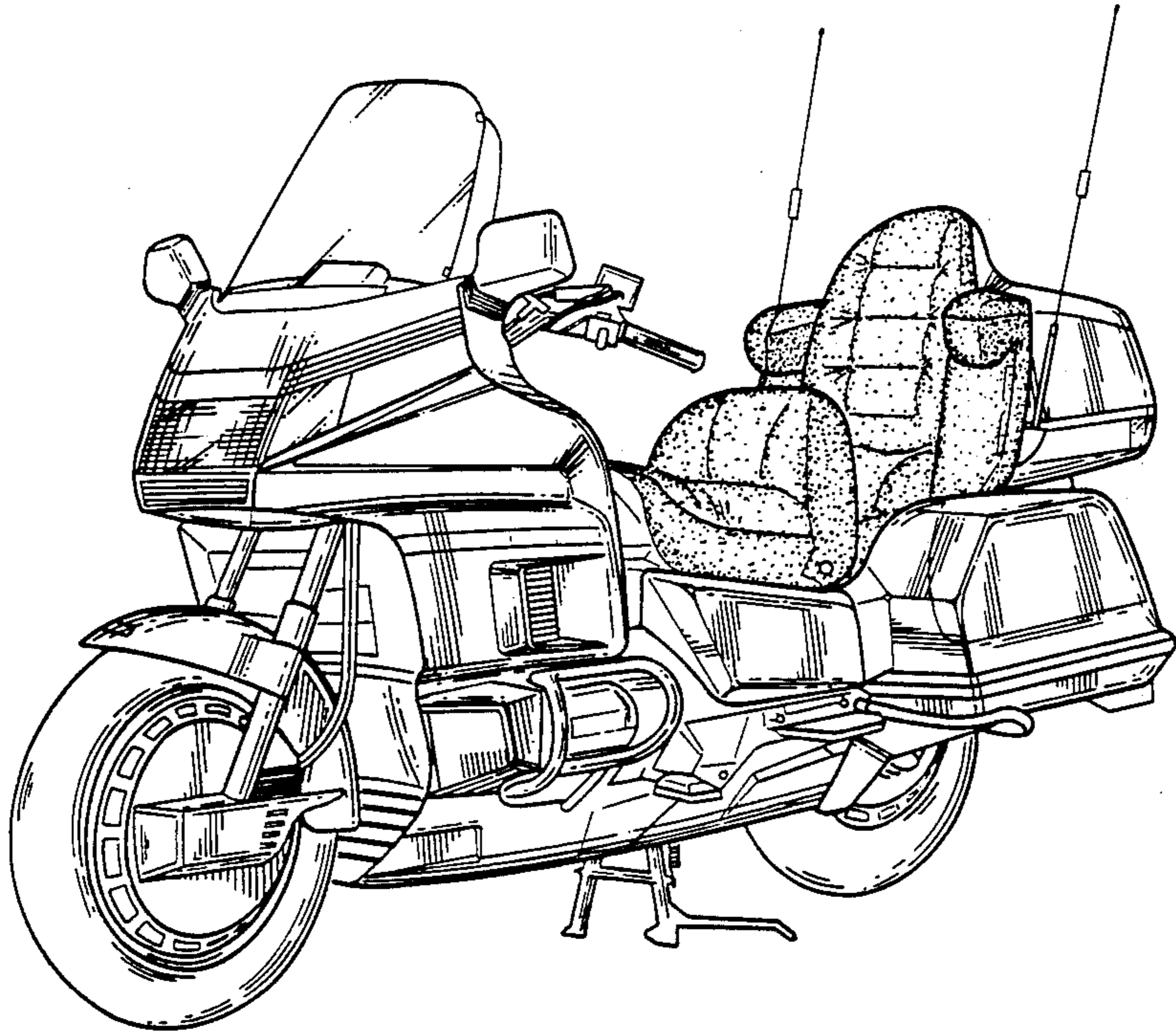

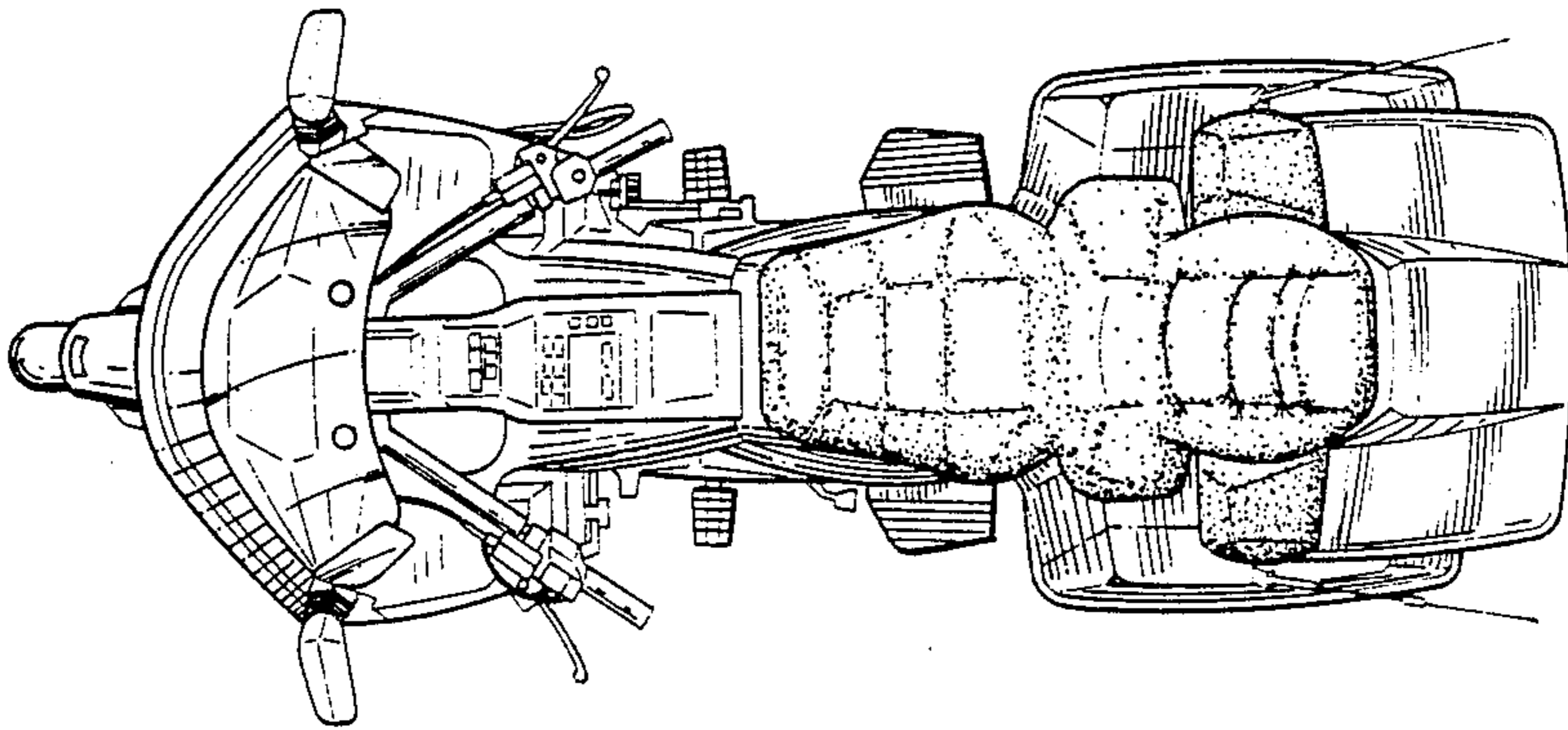

FIG. 1.

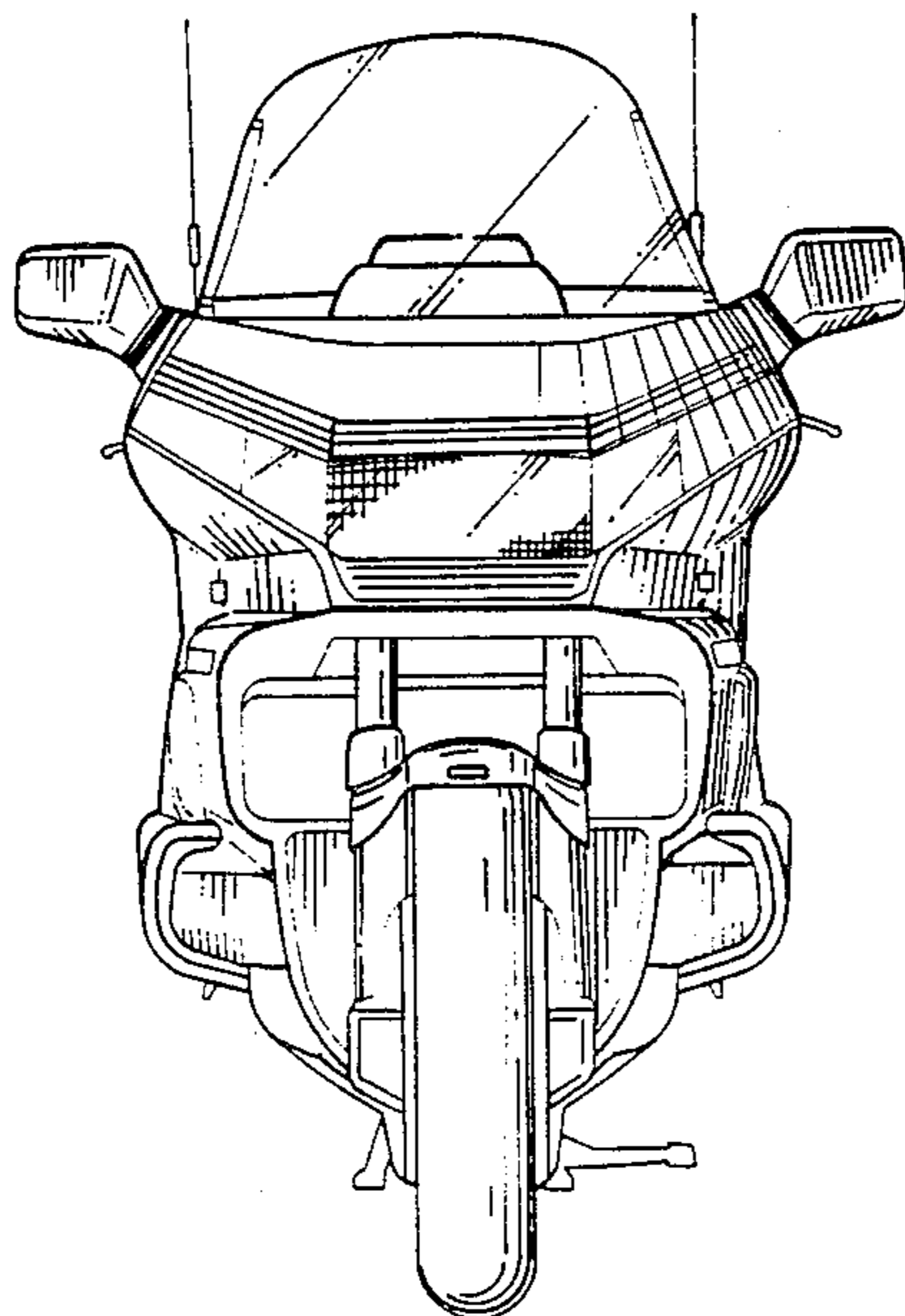

FIG. 2.

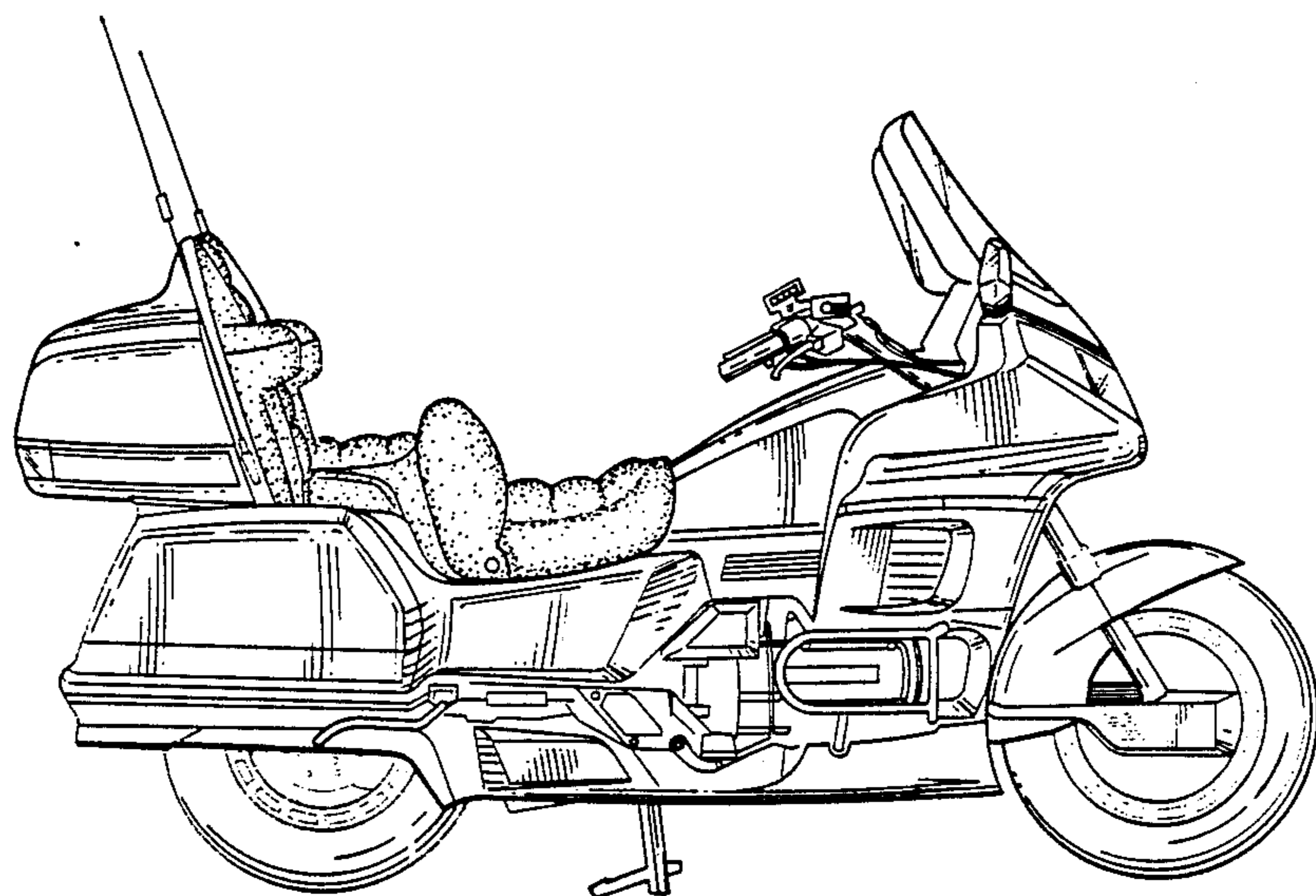

FIG. 3

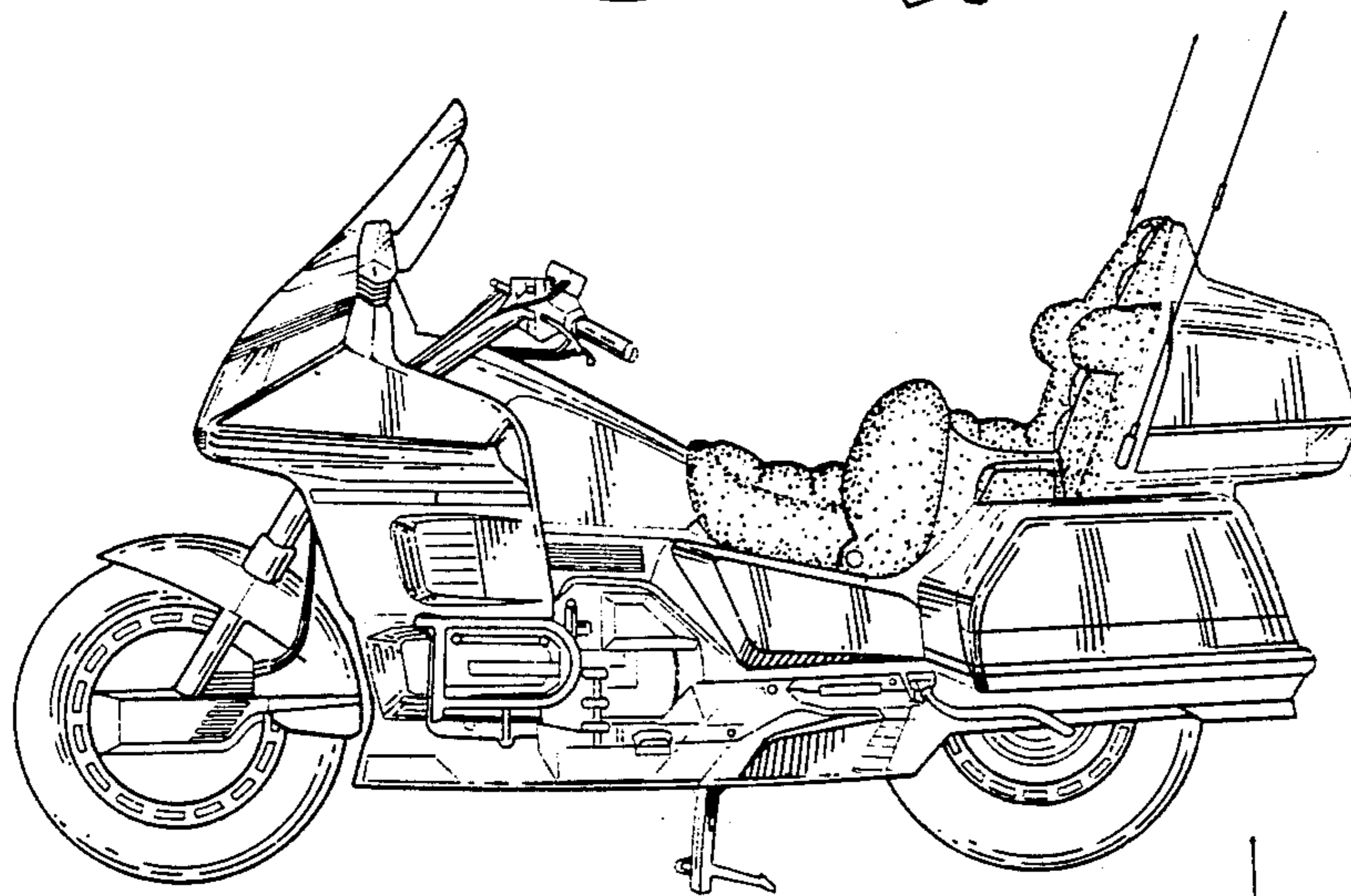

FIG. 4

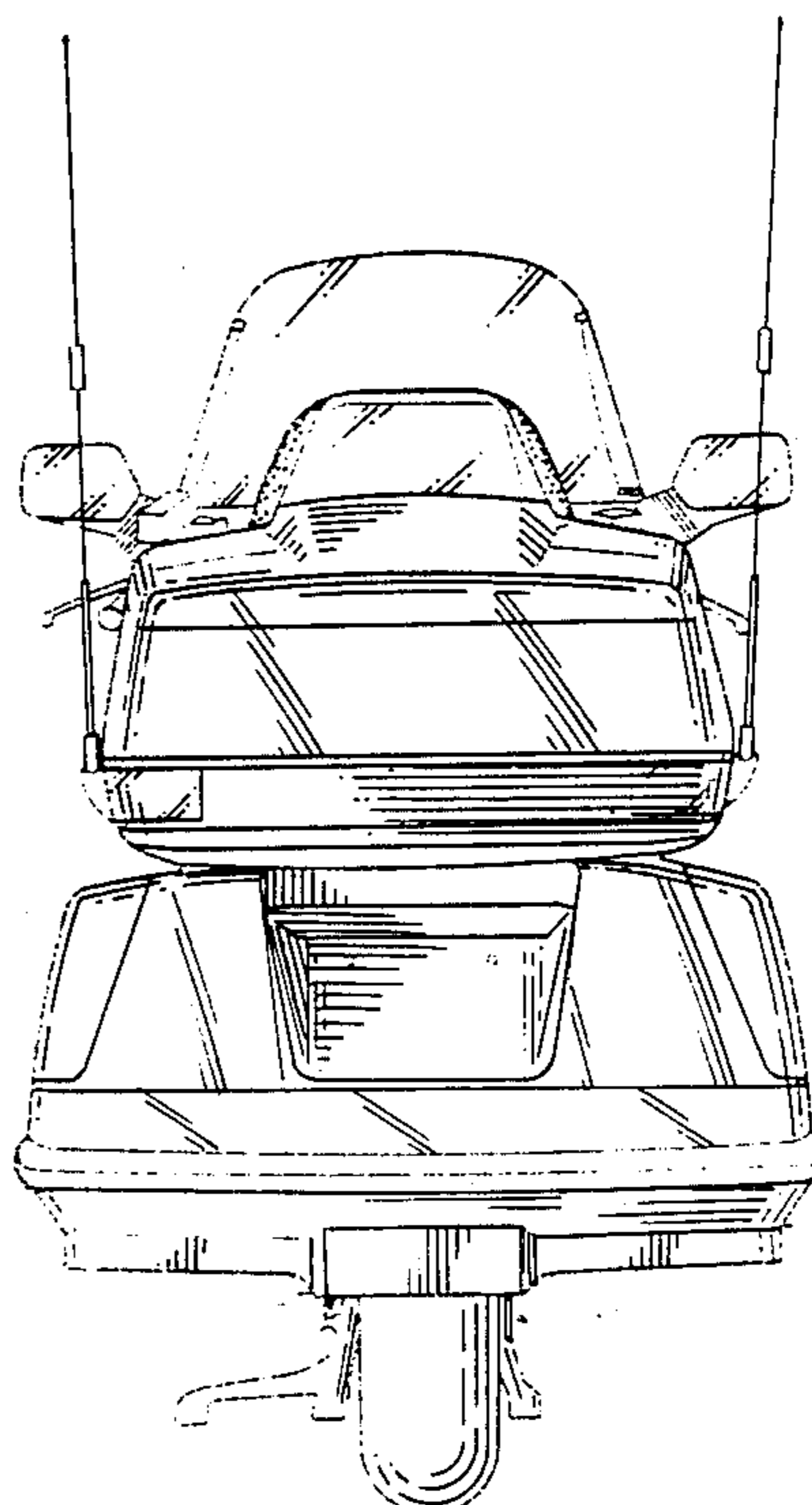
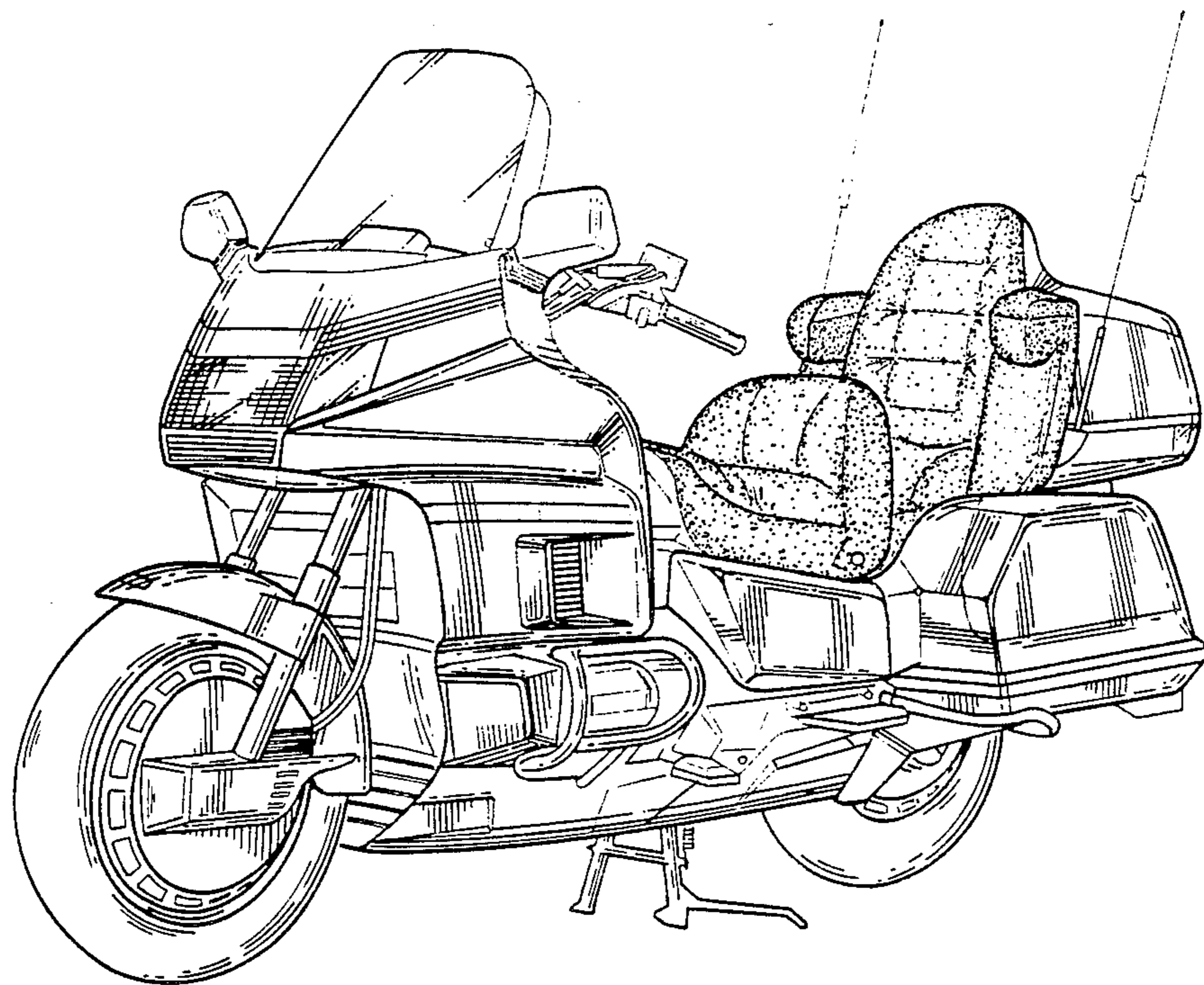

FIG. 5



*FIG. 6.*