

[54] COMBINATION TELEPHONE AND ANSWERING SET

[75] Inventor: Arthur T. Martinez, Long Beach, Calif.

[73] Assignee: Fortel Corporation, Compton, Calif.

[**] Term: 14 Years

[21] Appl. No.: 779,207

[22] Filed: Sep. 23, 1985

[52] U.S. Cl. D14/52; D14/4; D14/57; D14/63

[58] Field of Search D14/53, 52, 57, 4, 60, D14/62, 63; 179/179, 100 L, 100 R, 100 D, 101, 102, 103

[56] References Cited

U.S. PATENT DOCUMENTS

D. 227,784	7/1973	Jandu et al.	D14/4
D. 238,585	1/1976	Derwood	D14/52 X
D. 262,207	12/1981	Kaczkos	D14/64 X
D. 266,162	9/1982	Martinez	D14/4
D. 267,007	11/1982	Chiou	D14/53 X
D. 279,372	6/1985	Baba et al.	D14/4 X
D. 282,655	2/1986	Kaku et al.	D14/4
D. 283,614	4/1986	Somarchini	D14/63 X
D. 284,368	6/1986	Stonsbury, Jr.	D14/4
D. 285,554	9/1986	Beaumont et al.	D14/52
D. 286,404	10/1986	Skigen et al.	D14/63

OTHER PUBLICATIONS

Best catalog-1983-84, at p. 332: Record-A-Call Model CAT-2, Item #5.

DAK Industries, Inc., catalog-Early Summer 1985: at p. 65; DAK's Voice Print Answering Mach.; top left Fig.

B. A. Pargh Co., Inc.; 1983 catalog ©: at p. 33, bottom, Model KXT1420, Panasonic Answerer.

Best catalog 1984-85; at p. 296, "Cobra" Answer Machine; Model AN3100.

Primary Examiner—Wallace R. Burke

Assistant Examiner—Horace B. Fay

Attorney, Agent, or Firm—Paul R. Wylie

[57] CLAIM

The ornamental design for a combination telephone and answering set, as shown and described.

DESCRIPTION

FIG. 1 is a front, top and right side perspective view of a combination telephone and answering set showing my new design;

FIG. 2 is a top plan view thereof;

FIGS. 3 and 4 are respectively left and right side elevational views thereof;

FIG. 5 is a front elevational view thereof;

FIG. 6 is a rear elevational view thereof;

FIG. 7 is a bottom plan view thereof;

FIG. 8 is a front, top and right side perspective view of the stand thereof, and a right side and bottom perspective view of the handset thereof.

The cords of the set are omitted in some views and shown only fragmentarily in FIG. 6 for ease of illustration.

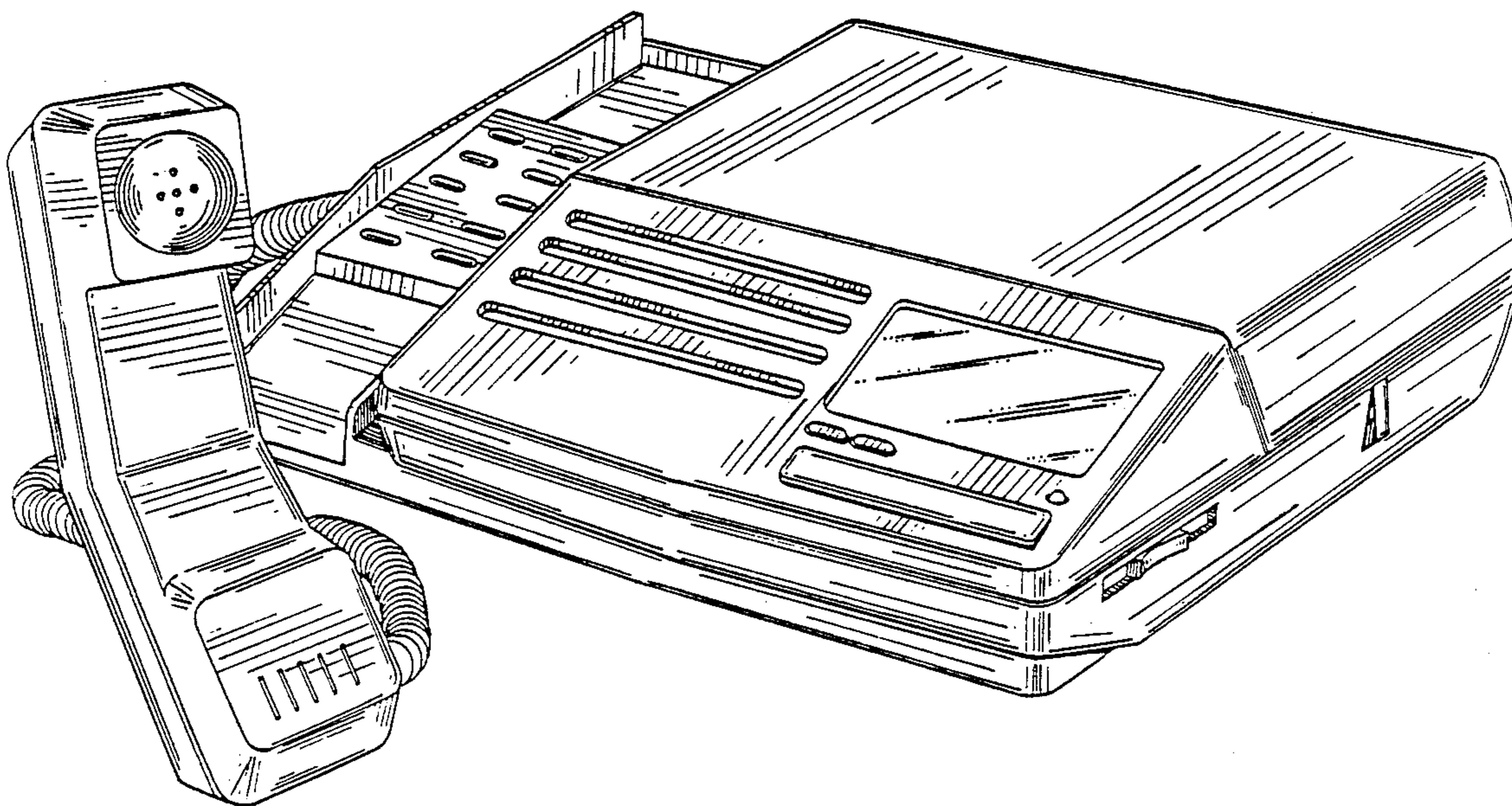

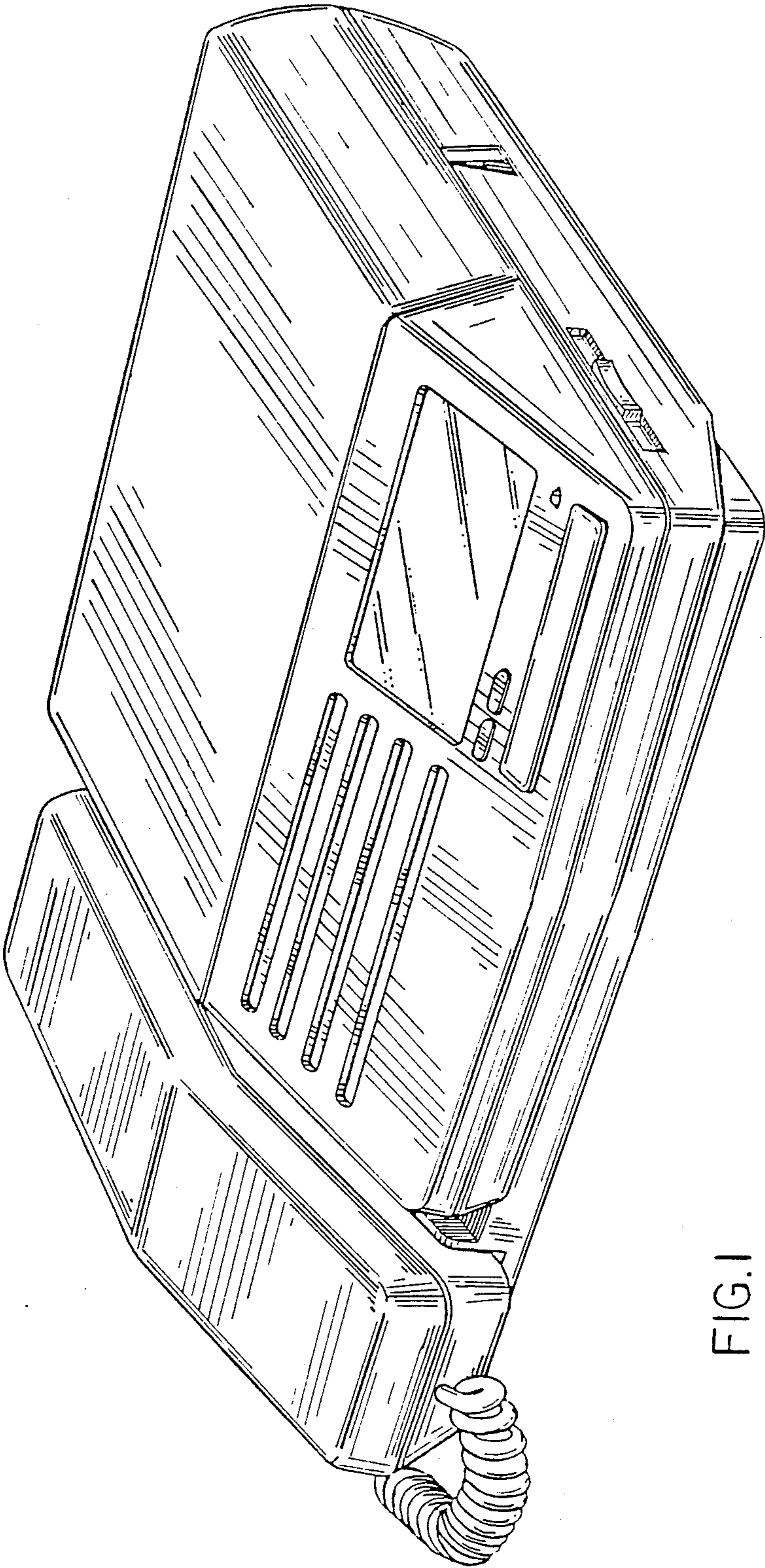
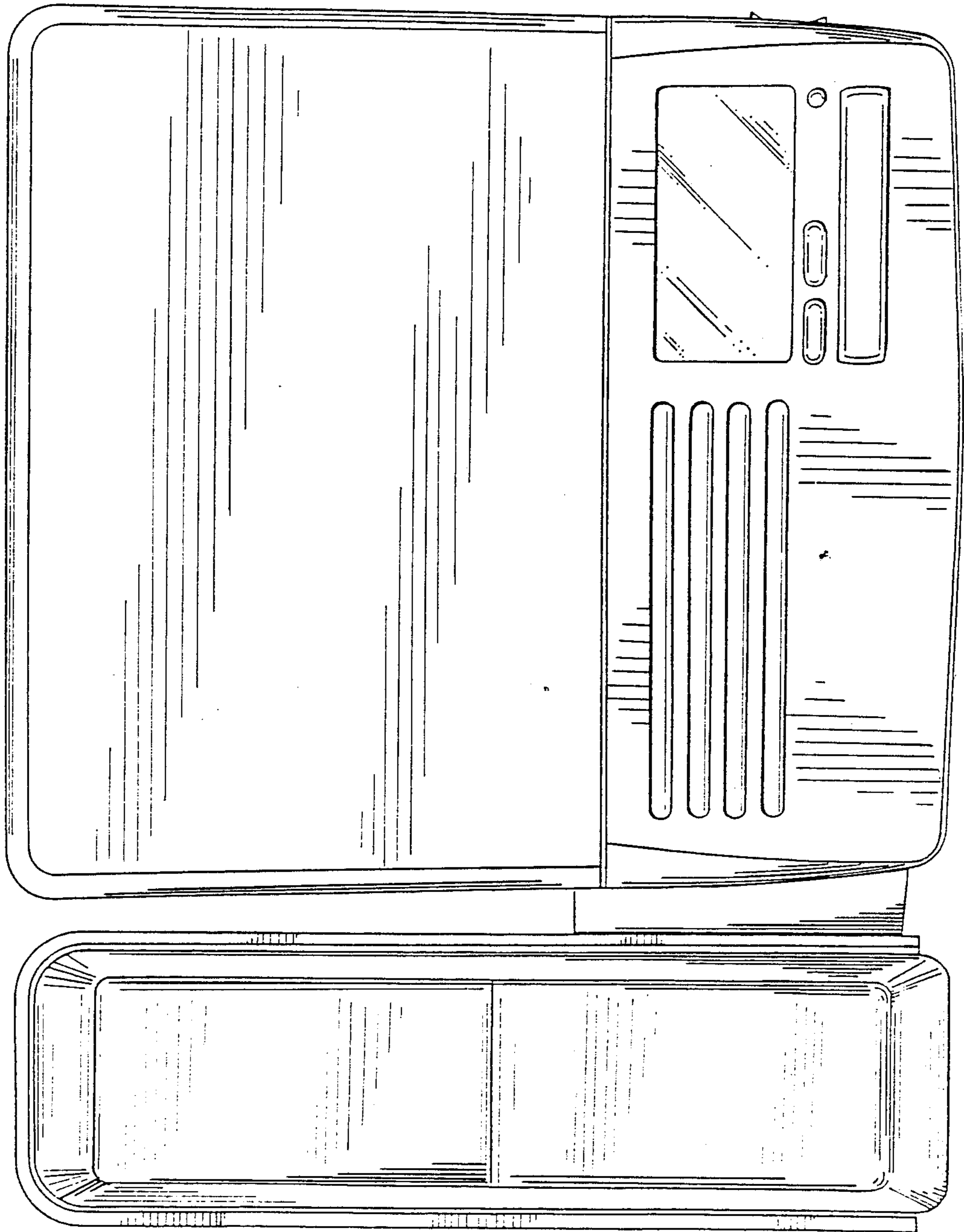

FIG. 1

FIG. 2



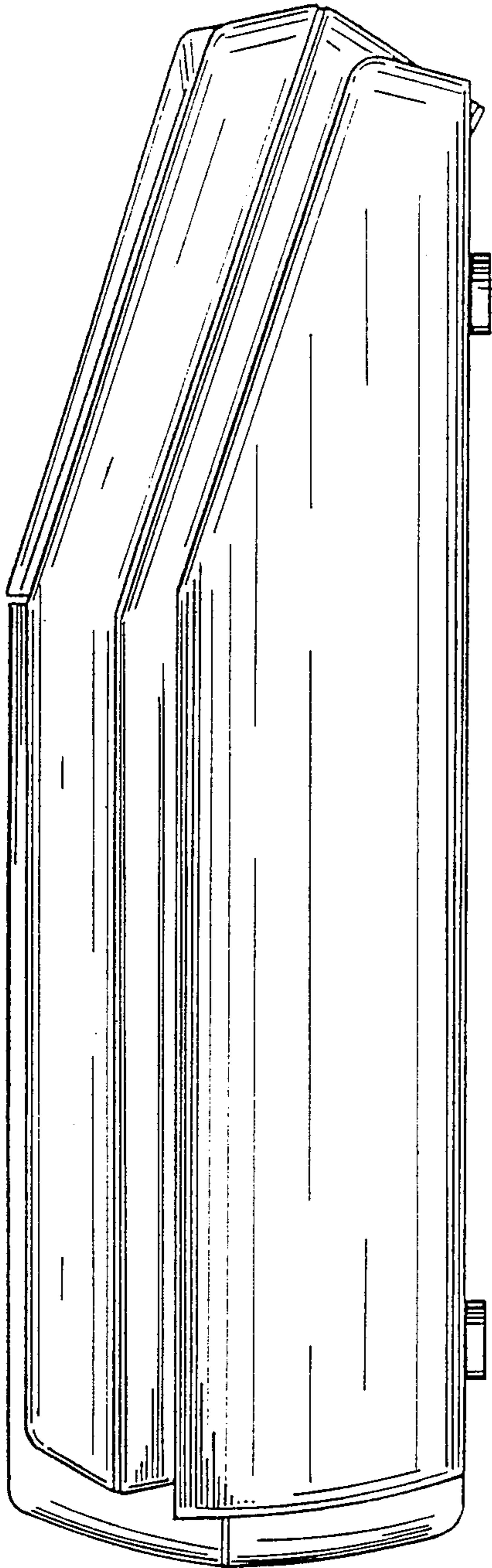

FIG. 3

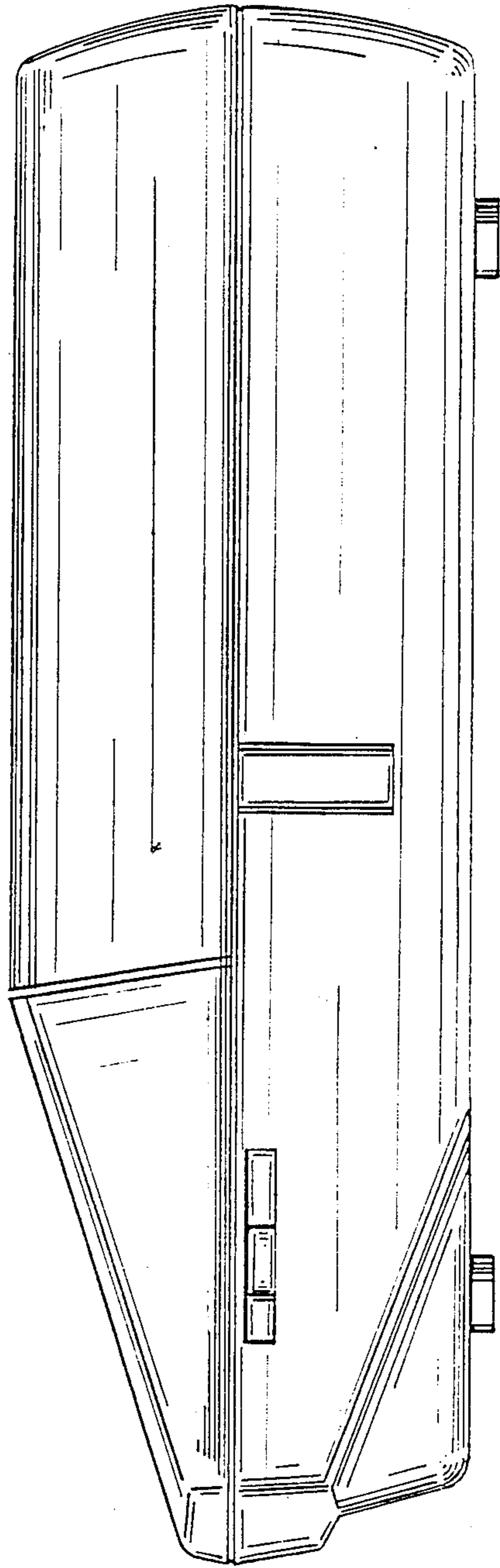

FIG. 4

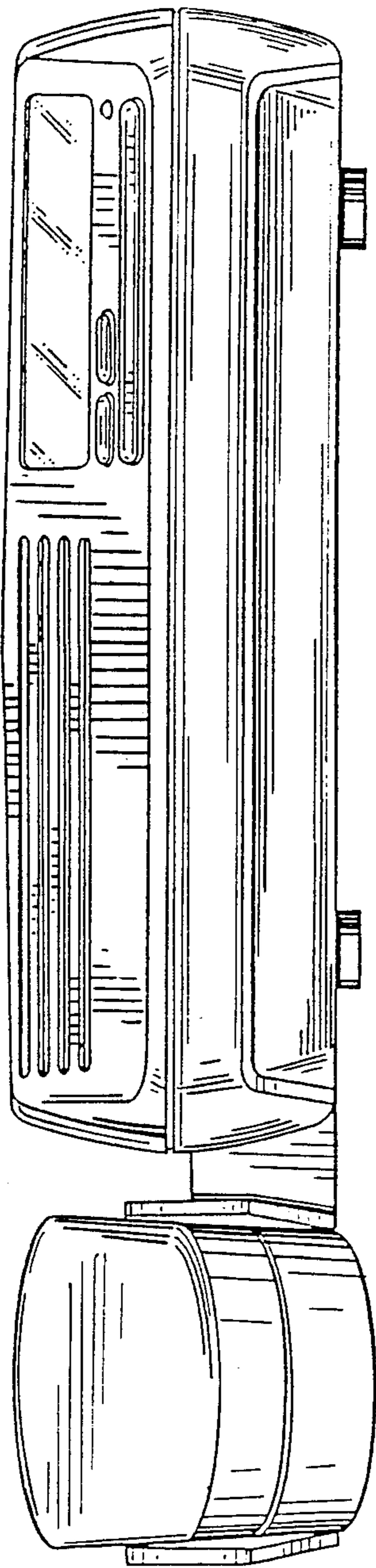

FIG. 5

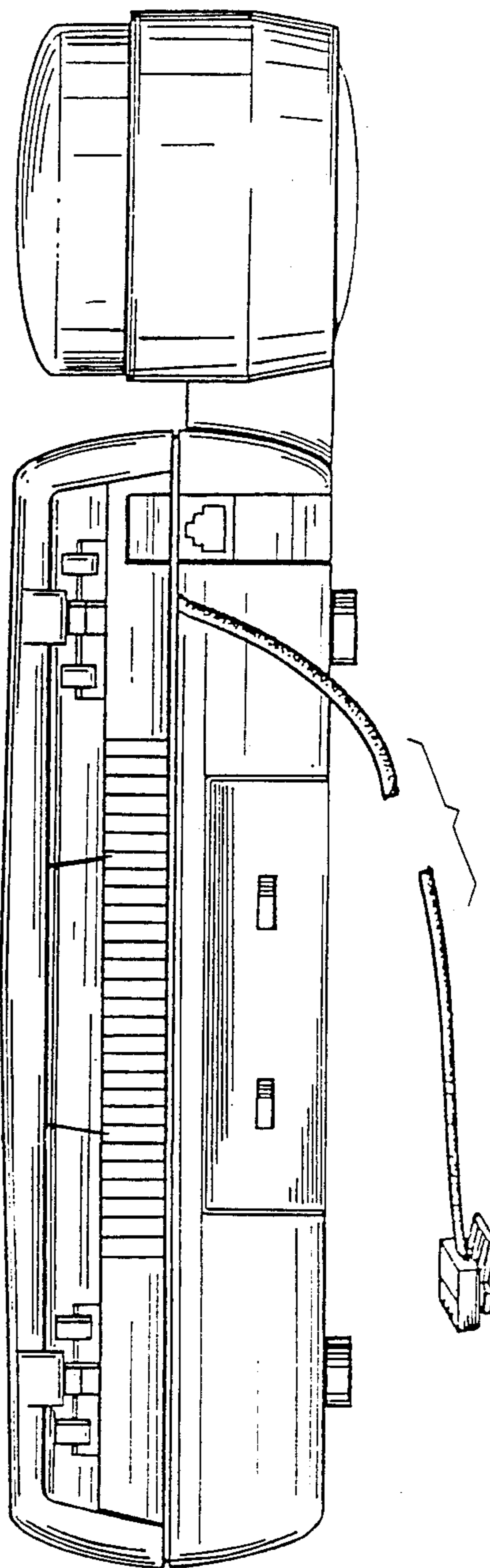
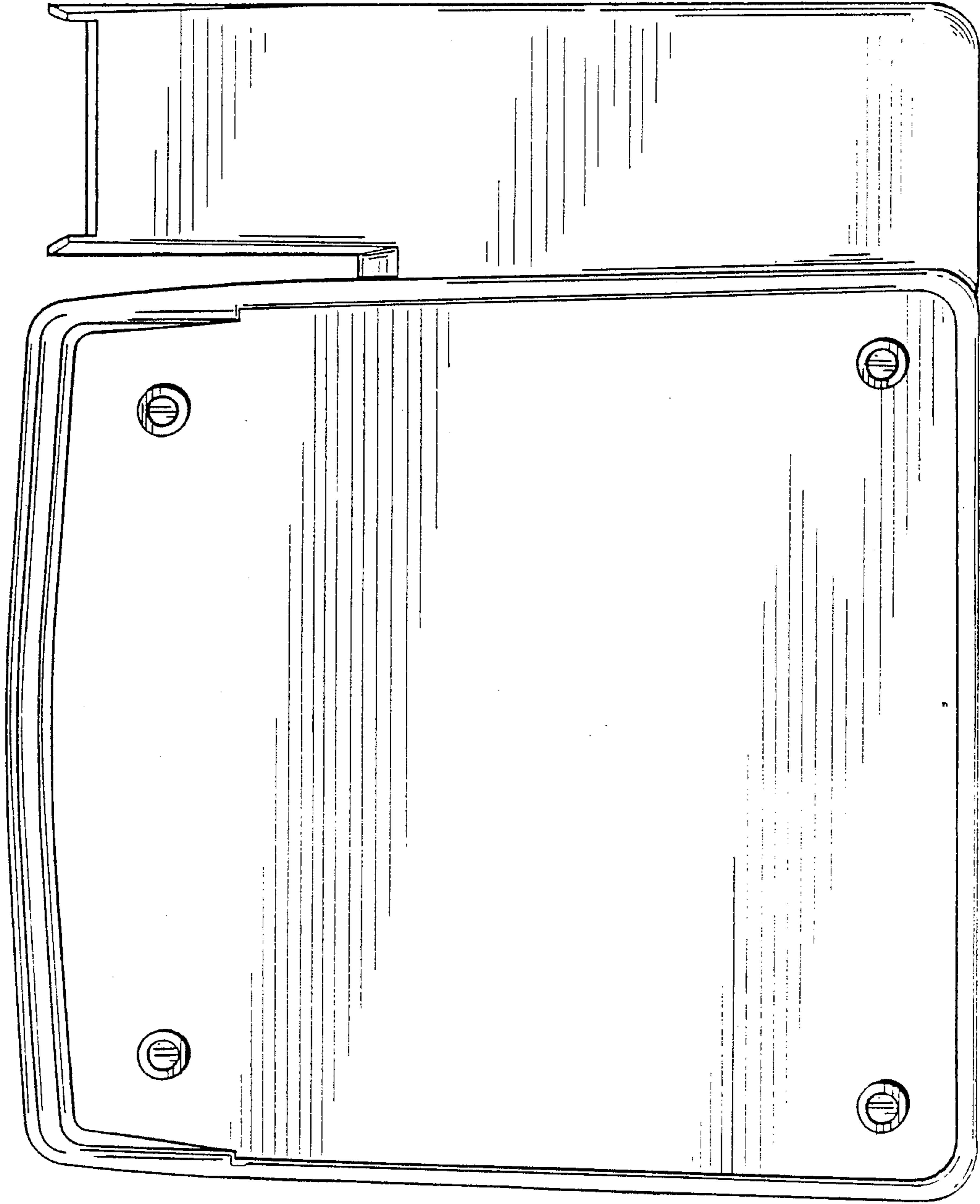

FIG. 6

FIG. 7



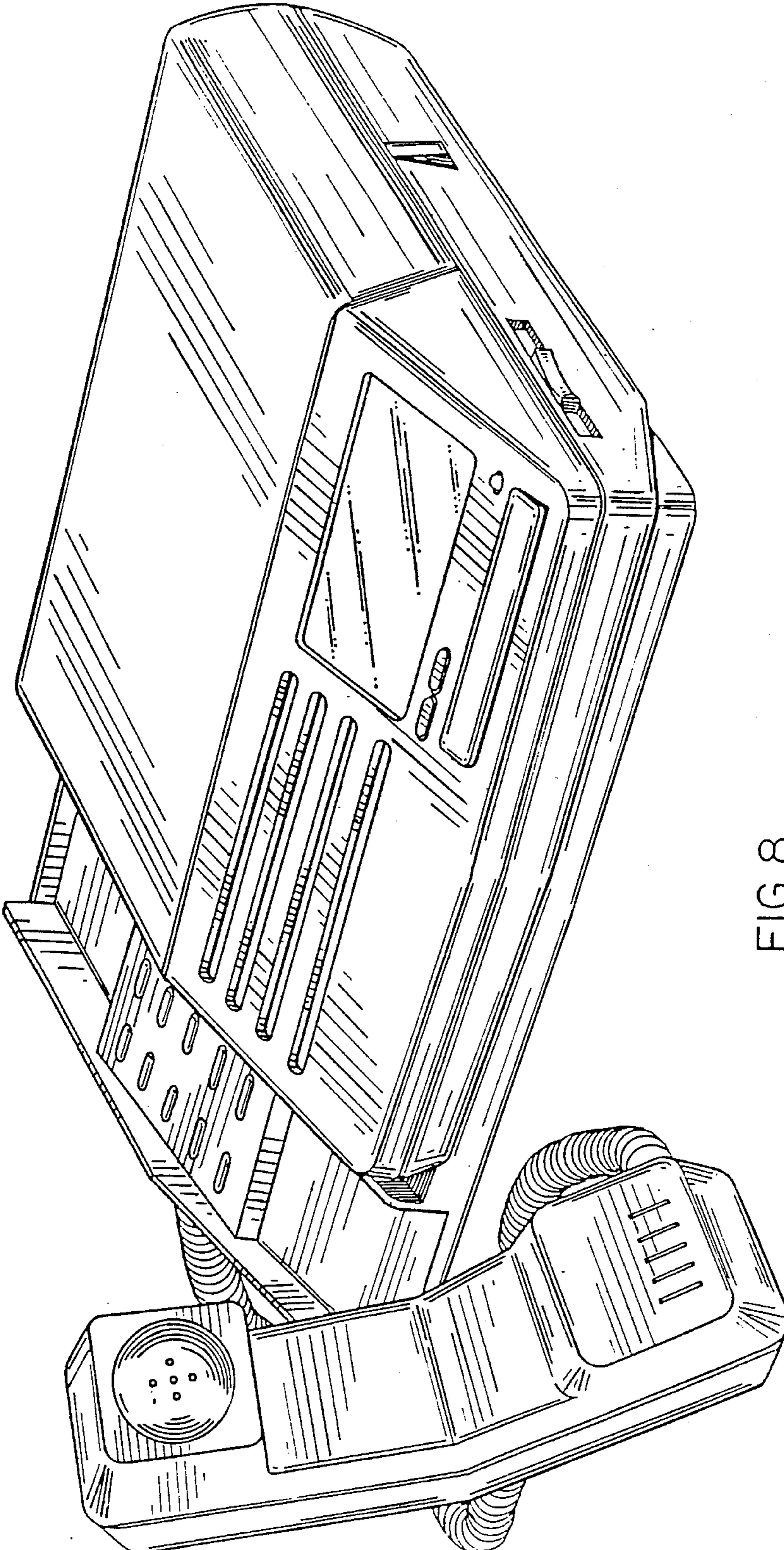

FIG.8