

[54] CONSTRUCTION BLOCK  
 [75] Inventor: Paul J. Forsberg, Richfield, Minn.  
 [73] Assignee: Keystone Retaining Wall Systems, Inc., Edina, Minn.  
 [\*\*] Term: 14 Years  
 [21] Appl. No.: 909,097

[22] Filed: Sep. 18, 1986  
 [52] U.S. Cl. .... D25/116  
 [58] Field of Search ..... 405/284, 285, 286, 33;  
 404/41, 42, 34; 52/608, 605; D25/113, 114, 116,  
 58

[56] **References Cited**  
**U.S. PATENT DOCUMENTS**

D. 237,704	11/1974	Lane .....	D25/116
126,547	5/1872	Hickox .	
228,052	5/1880	Frost .	
566,924	9/1896	Morrin .	
810,748	1/1906	Haller et al. .	
1,092,621	4/1914	Worner .	
1,456,498	5/1923	Binns .	
2,235,646	3/1941	Schaffer .	
2,963,828	12/1960	Belliveau .	
3,036,407	5/1962	Dixon .	
3,274,742	9/1966	Paul, Jr. et al. .	
3,390,502	7/1968	Carroll .	
3,430,404	3/1969	Muse .	
3,557,505	1/1971	Kaul .	
3,936,987	2/1976	Calvin .	
3,995,434	12/1976	Kato et al. .	
4,016,693	4/1977	Warren .....	52/605 X
4,110,948	9/1978	Cambiuzzi et al. .	
4,207,718	6/1980	Schaaf et al. .	
4,208,805	6/1980	Collier .	

4,228,628	10/1980	Schlomann .	
4,229,123	10/1980	Heinzmann .	
4,335,549	6/1982	Dean .....	52/98
4,454,699	6/1984	Strobl .	
4,524,551	6/1985	Scheiwiller .	
4,572,699	2/1986	Rinninger .	

**FOREIGN PATENT DOCUMENTS**

392474	11/1908	France .
1385207	2/1975	United Kingdom .

**OTHER PUBLICATIONS**

The Besser Company bulletin, Feb. 1985.  
 The Hollow Building Tile Assoc. handbook, p. 11, Jan. 1924.  
 The Besser Company brochure, "Modular Concrete Block", 1984.  
 The Besser Company brochure, "Paving Stone", Jun. 1984.

*Primary Examiner*—A. Hugo Word  
*Attorney, Agent, or Firm*—Burd, Bartz & Gutenkauf

[57] **CLAIM**

The ornamental design for a construction block, as shown.

**DESCRIPTION**

FIG. 1 is a perspective view of the construction block showing my new design;  
 FIG. 2 is a top plan view thereof;  
 FIG. 3 is a bottom plan view thereof;  
 FIG. 4 is a front elevational view thereof;  
 FIG. 5 is a rear elevational view thereof;  
 FIG. 6 is a sectional view taken along the line 6—6 of FIG. 3; and  
 FIG. 7 is a sectional view taken along the line 7—7 of FIG. 2.

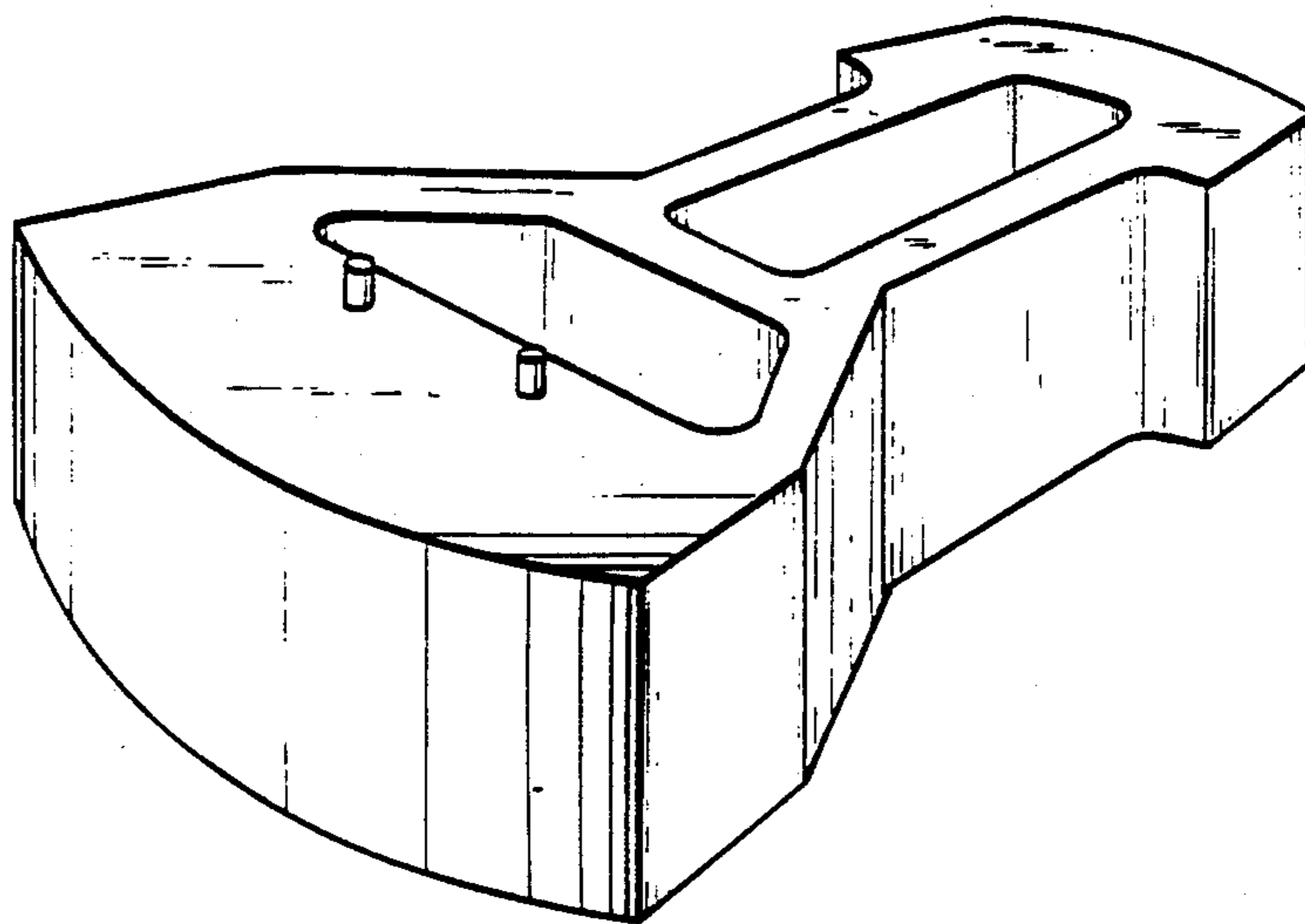

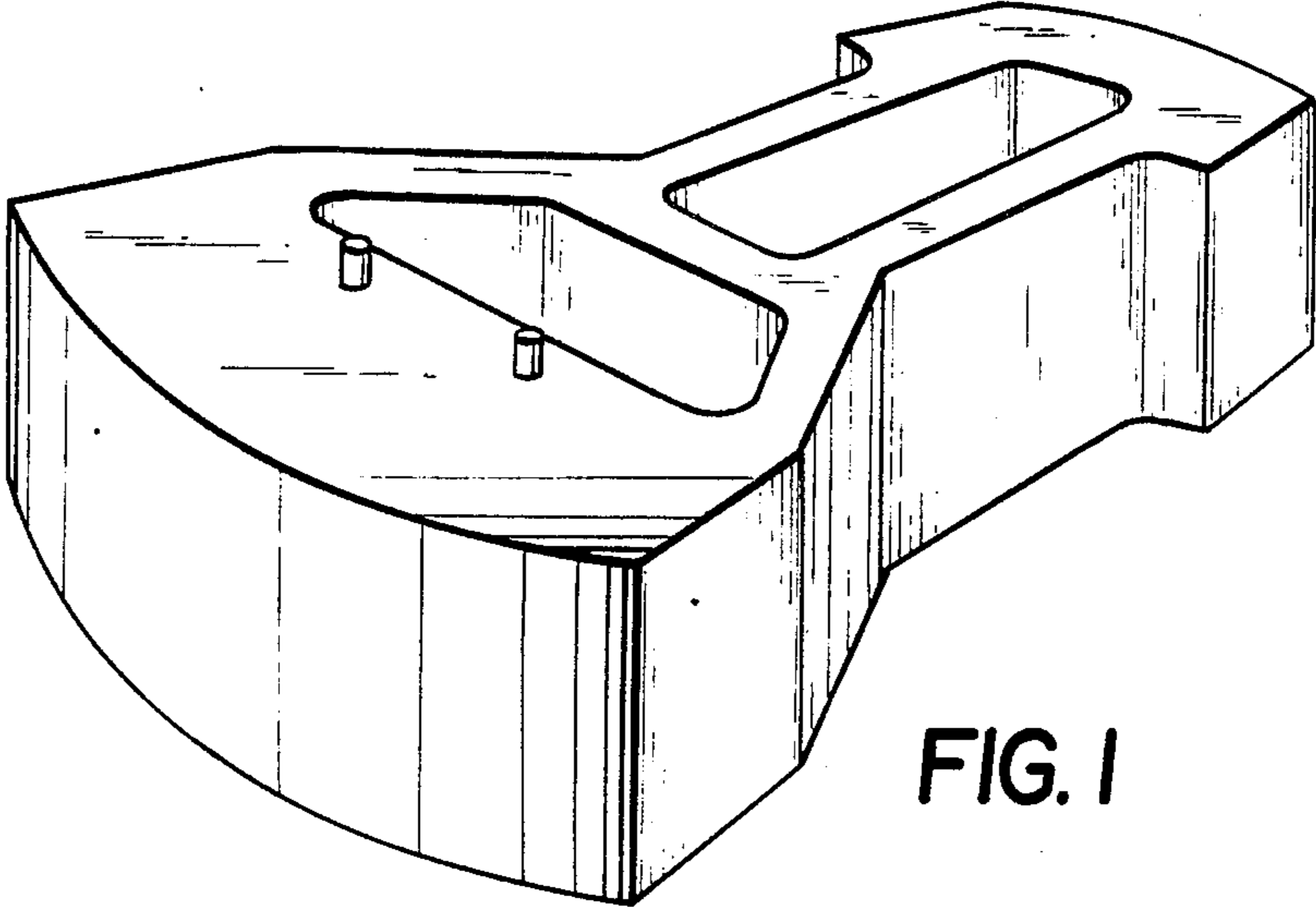

FIG. 1

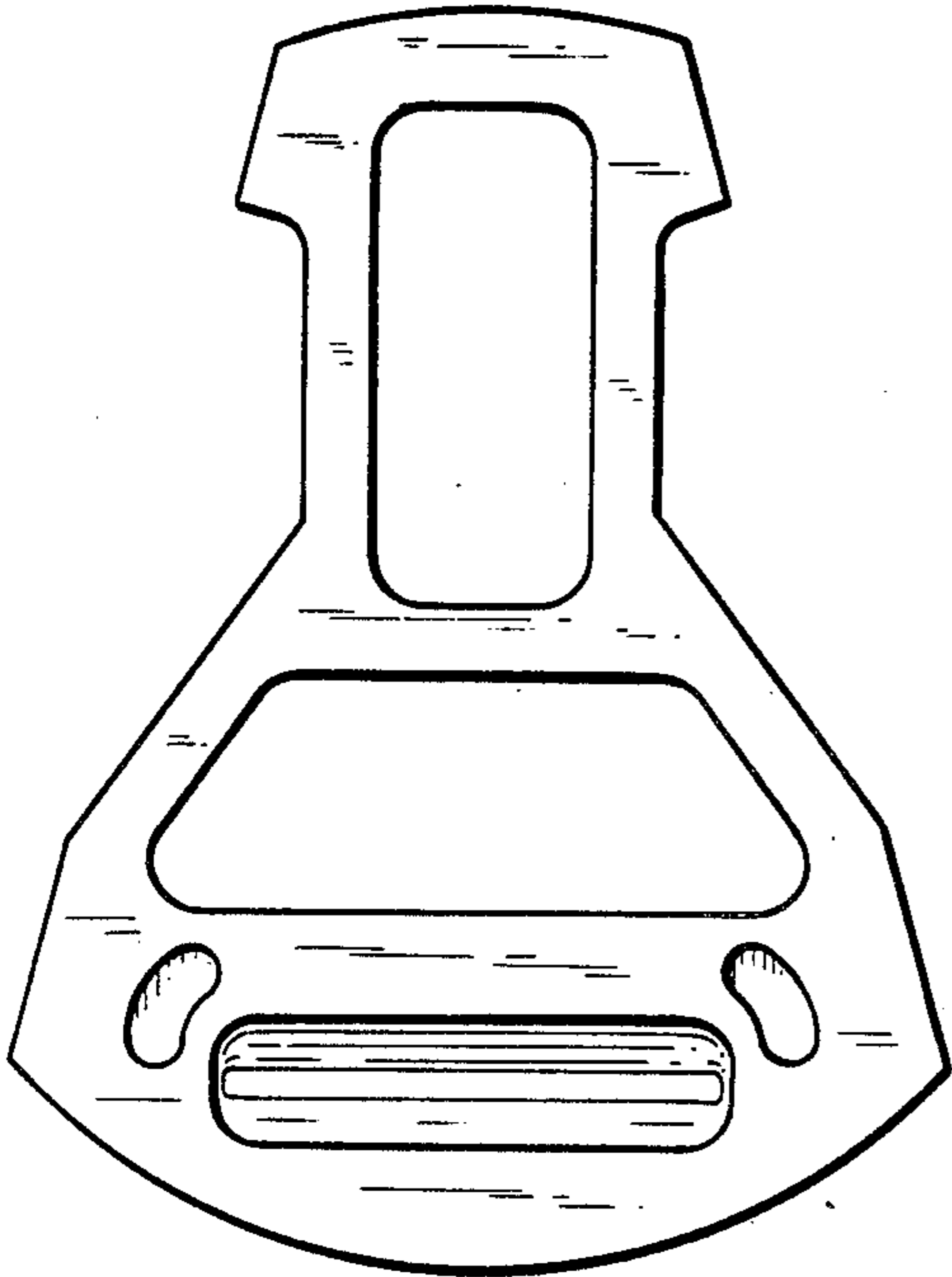

FIG. 3

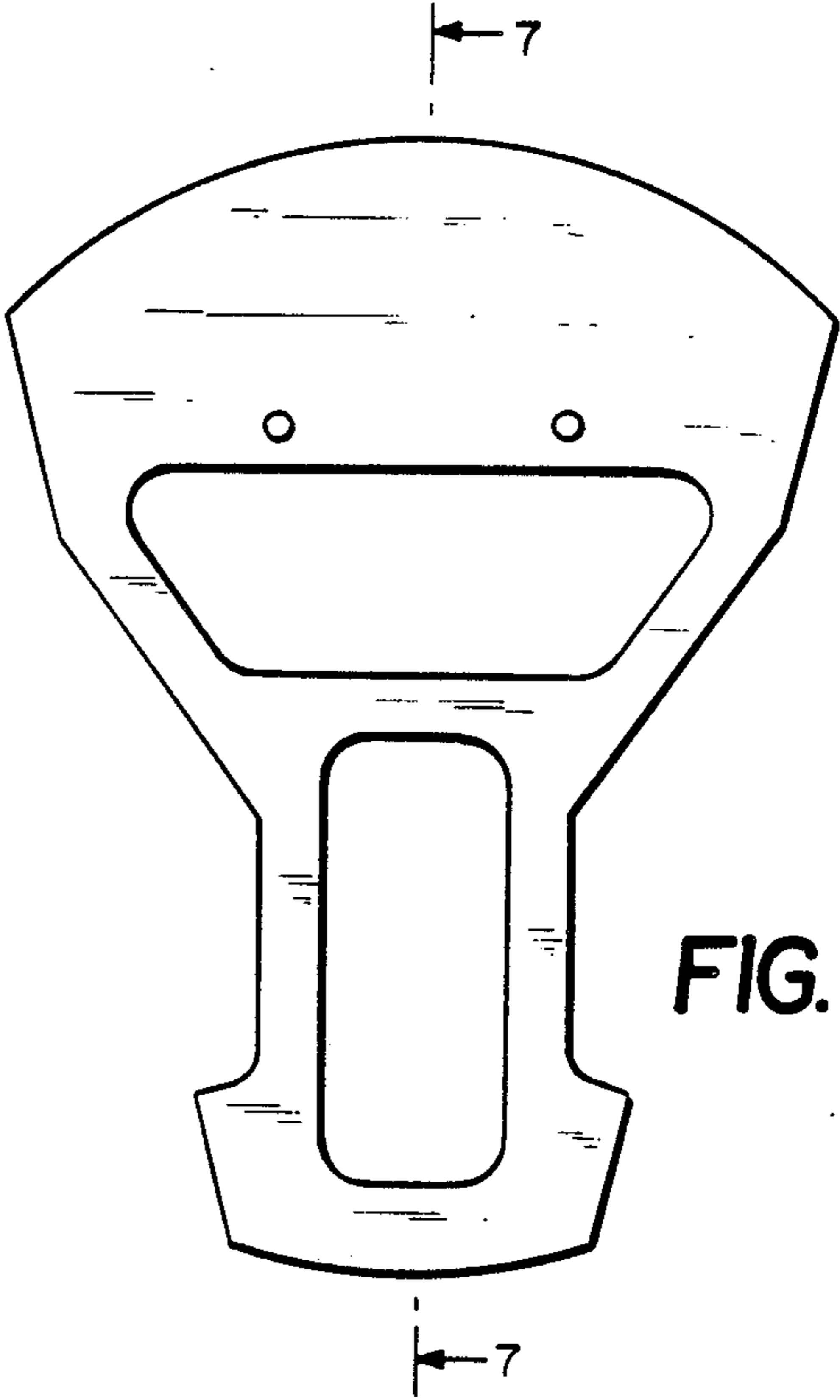

FIG. 2

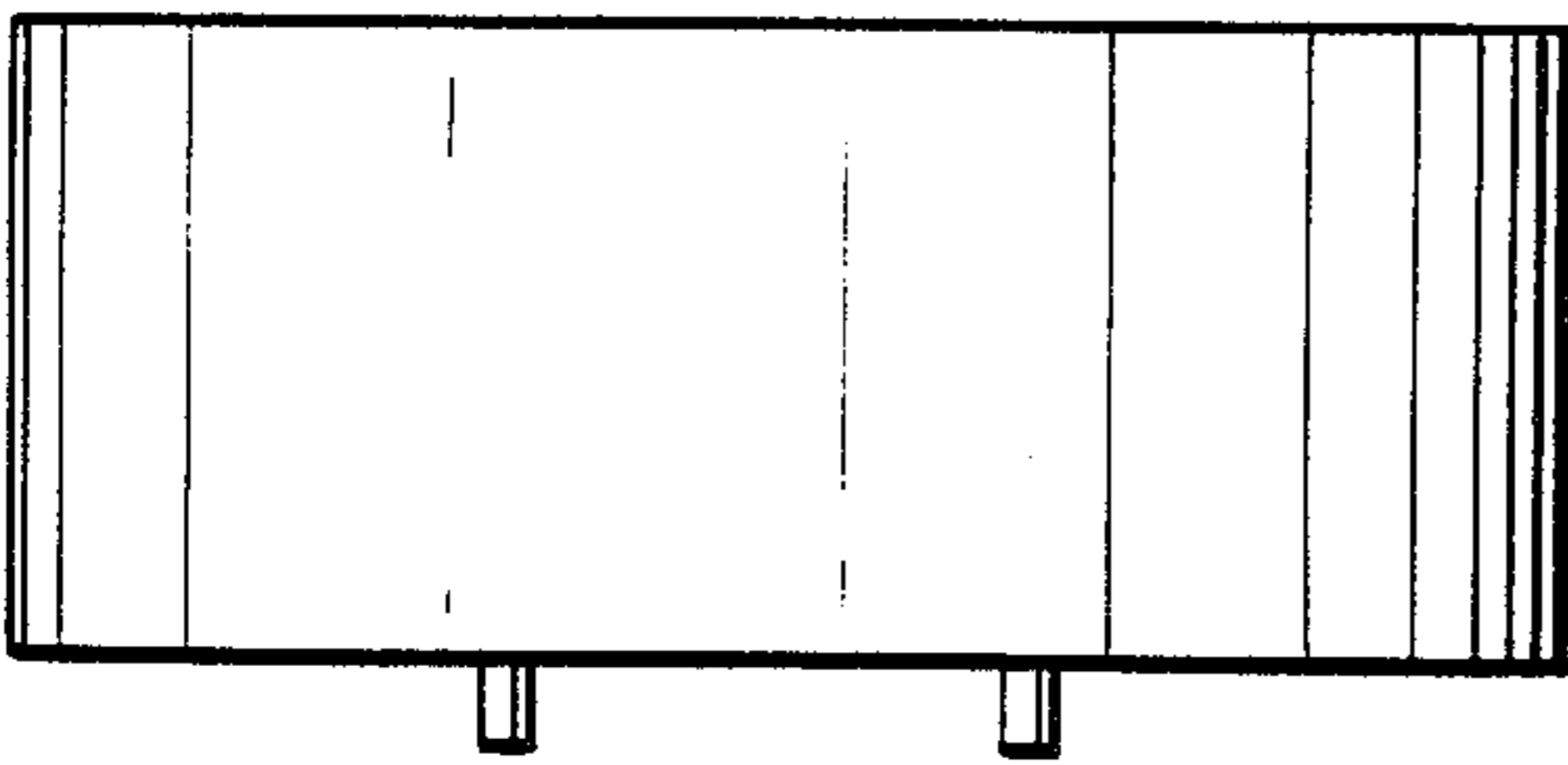

FIG. 4

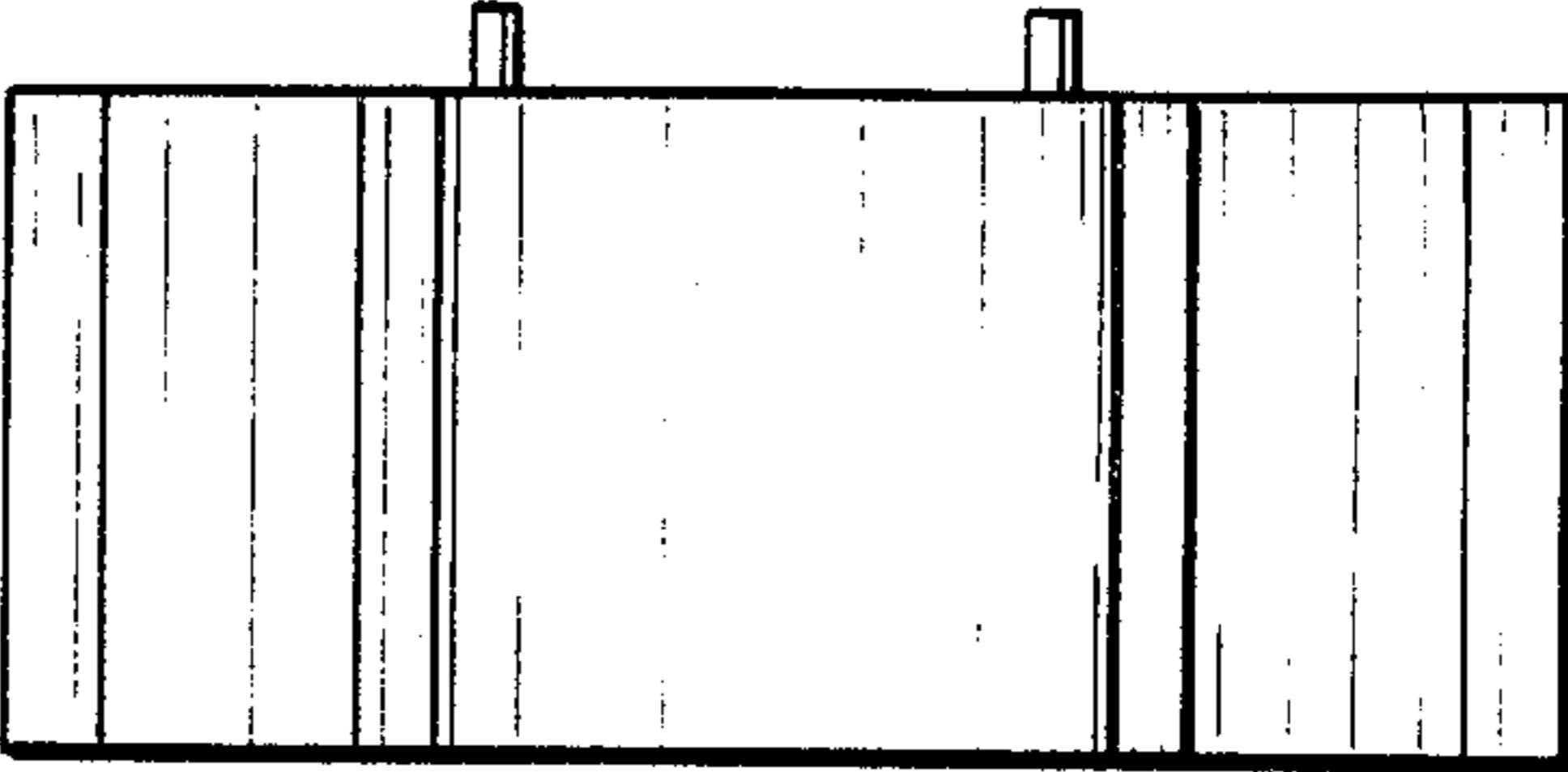

FIG. 5

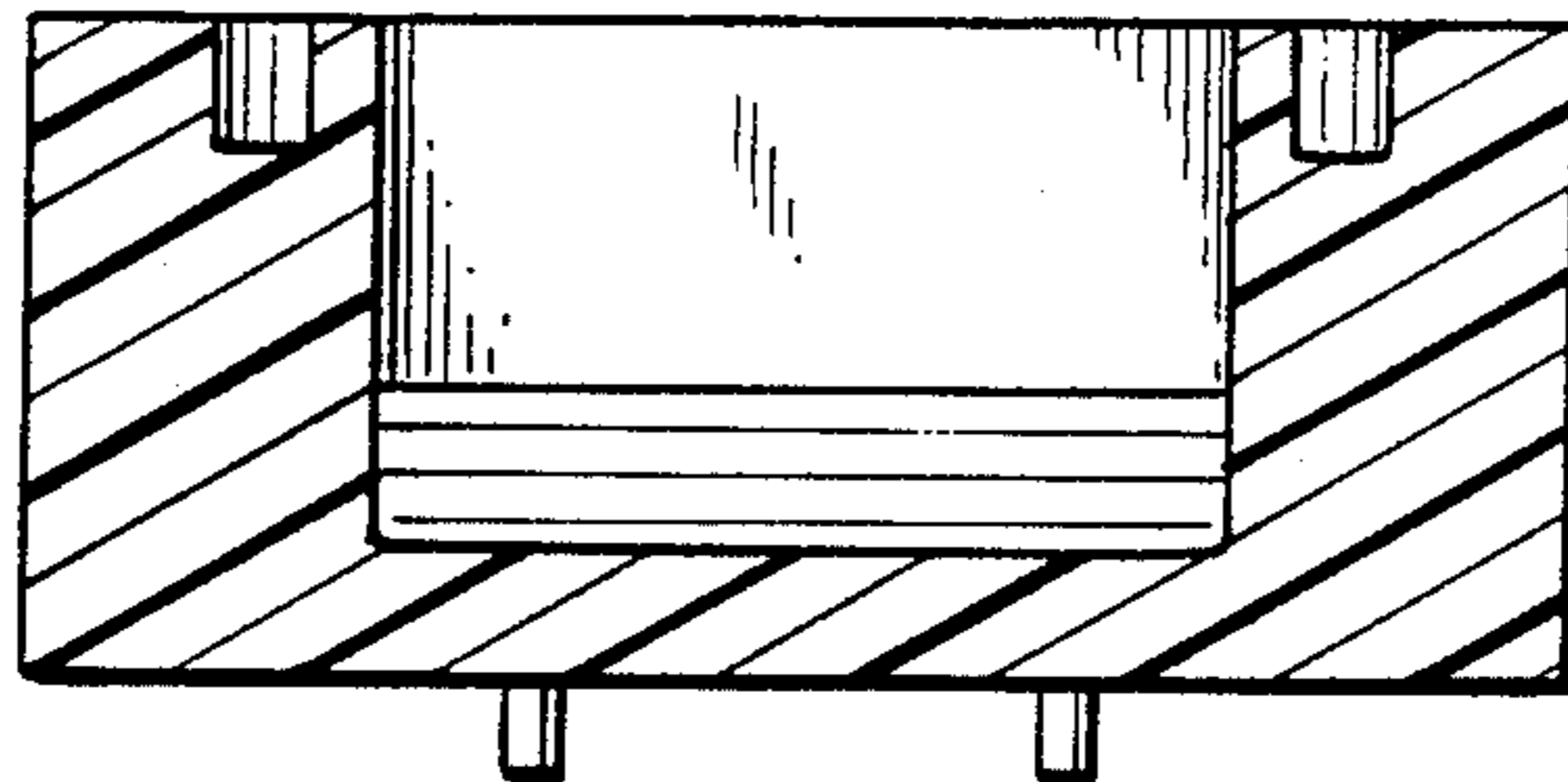

FIG. 6

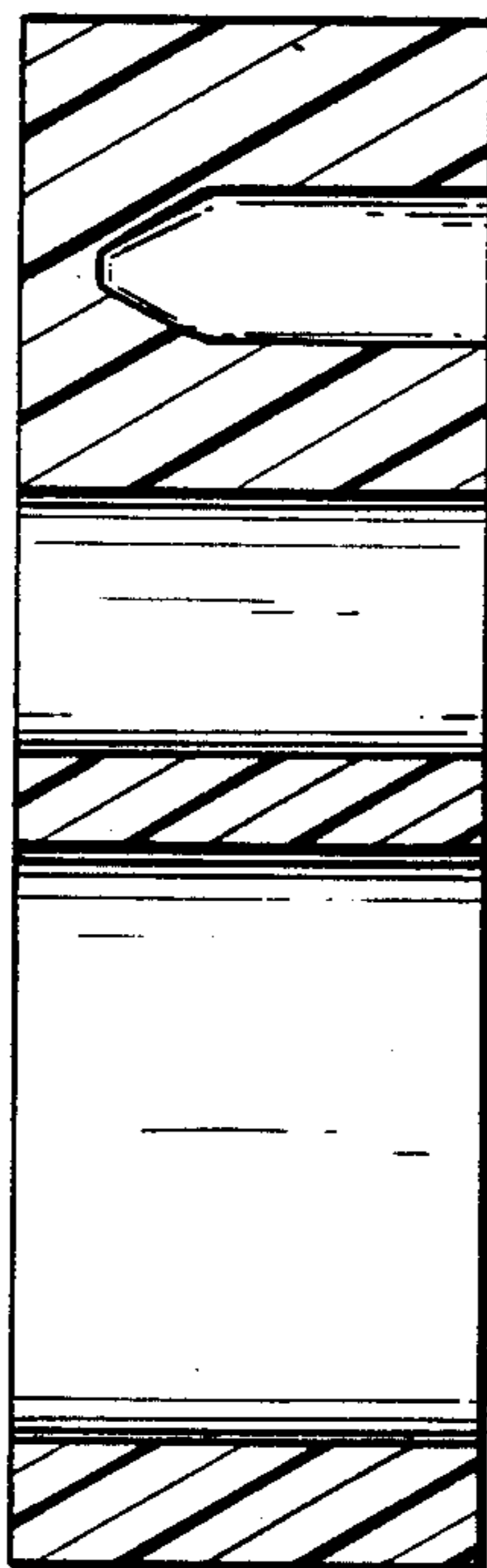

FIG. 7