

[54] TIRE

[75] Inventor: Giuliano Ghilardi, Sesto San Giovanni, Italy

[73] Assignee: Pirelli Coordinamento Pneumatici S.p.A., Italy

[**] Term: 14 Years

[21] Appl. No.: 834,877

[22] Filed: Feb. 24, 1986

[30] Foreign Application Priority Data

Aug. 30, 1985 [IT] Italy 22844/85[U]

[52] U.S. Cl. D12/142

[58] Field of Search D12/141-143,
D12/146-151, 136, 134; 152/209 R, 209 D

[56] References Cited

U.S. PATENT DOCUMENTS

3,494,401 2/1970 Bush 152/209 R
4,462,446 7/1984 Goergen et al. 152/209 R

OTHER PUBLICATIONS

Colliers, 3/22/47, p. 46, Firestone Imperial tire.
Colliers, 8/18/51, p. 39, Pennsylvania vacuum cup tire.

Primary Examiner—James M. Gandy
Attorney, Agent, or Firm—Stevens, Davis, Miller & Mosher

[57] CLAIM

The ornamental design for a tire, as shown and described.

DESCRIPTION

FIG. 1 is a perspective view of a tire showing my new design;

FIG. 2 is a front elevation view thereof;

FIG. 3 is a perspective view of a tire showing a second embodiment of my new design;

FIG. 4 is a front elevation view of FIG. 3; and

FIG. 5 is a side elevational view of both the first and second embodiments of the tire.

The tread pattern is understood to be repeated uniformly throughout the circumference of both embodiments of the tire as shown schematically in solid lines and the opposite side is substantially the same as the side shown.

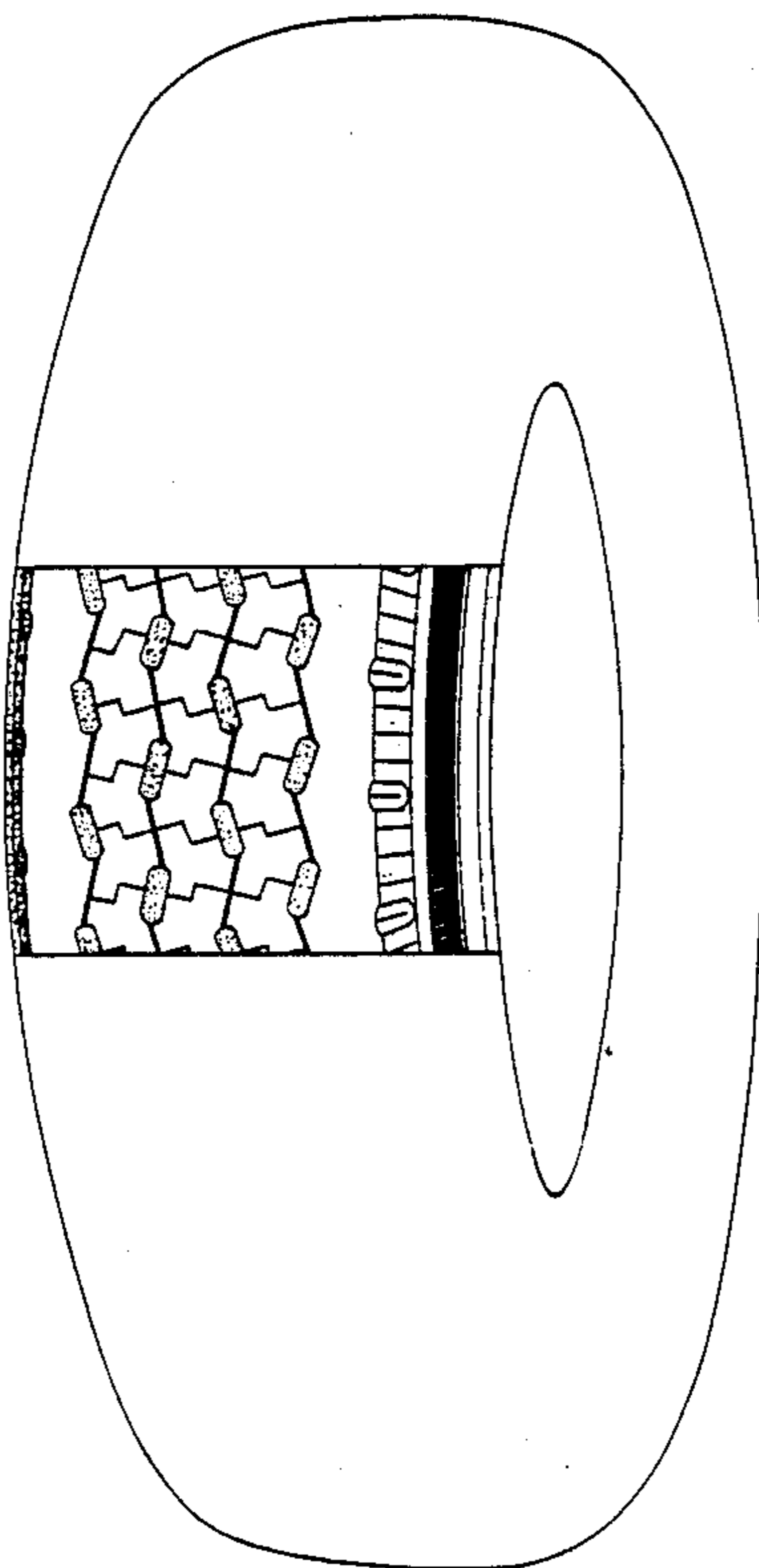

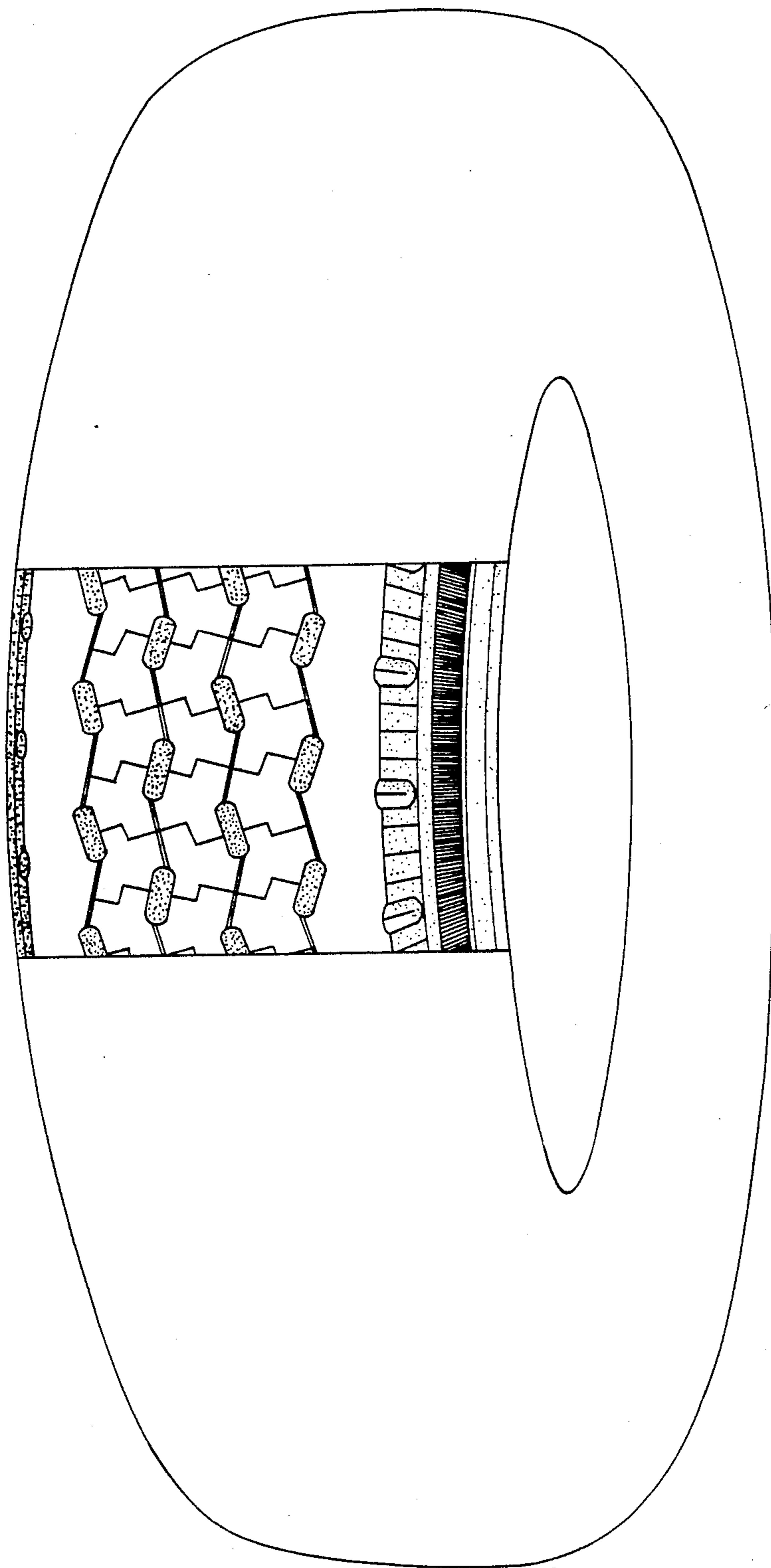

FIG 1

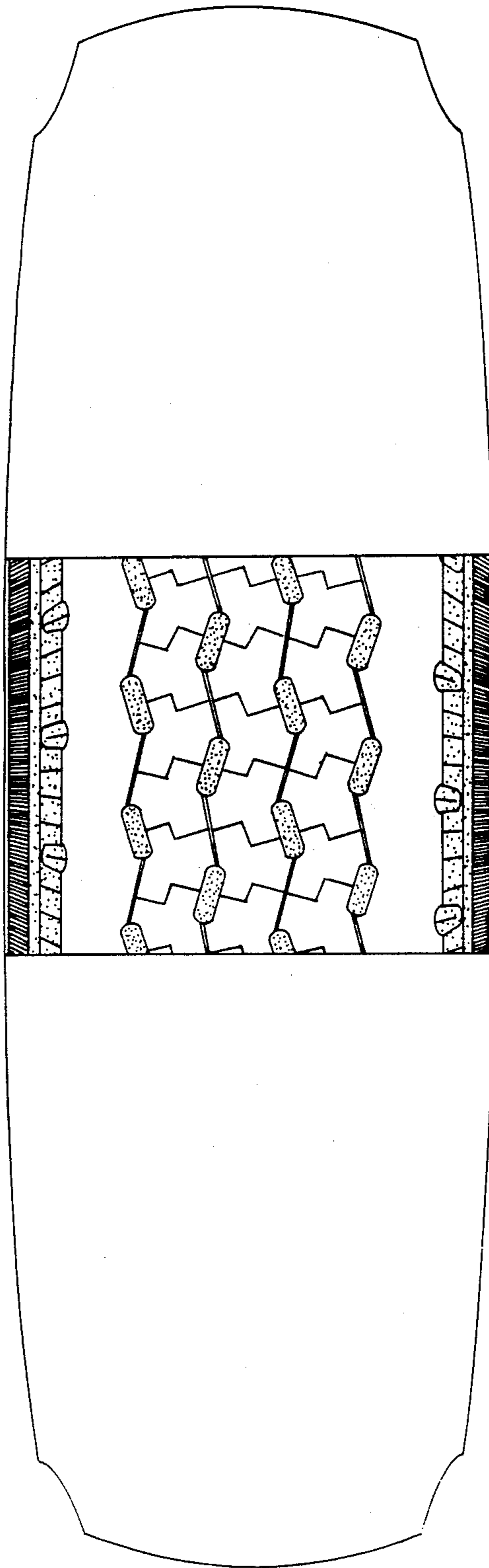

FIG 2

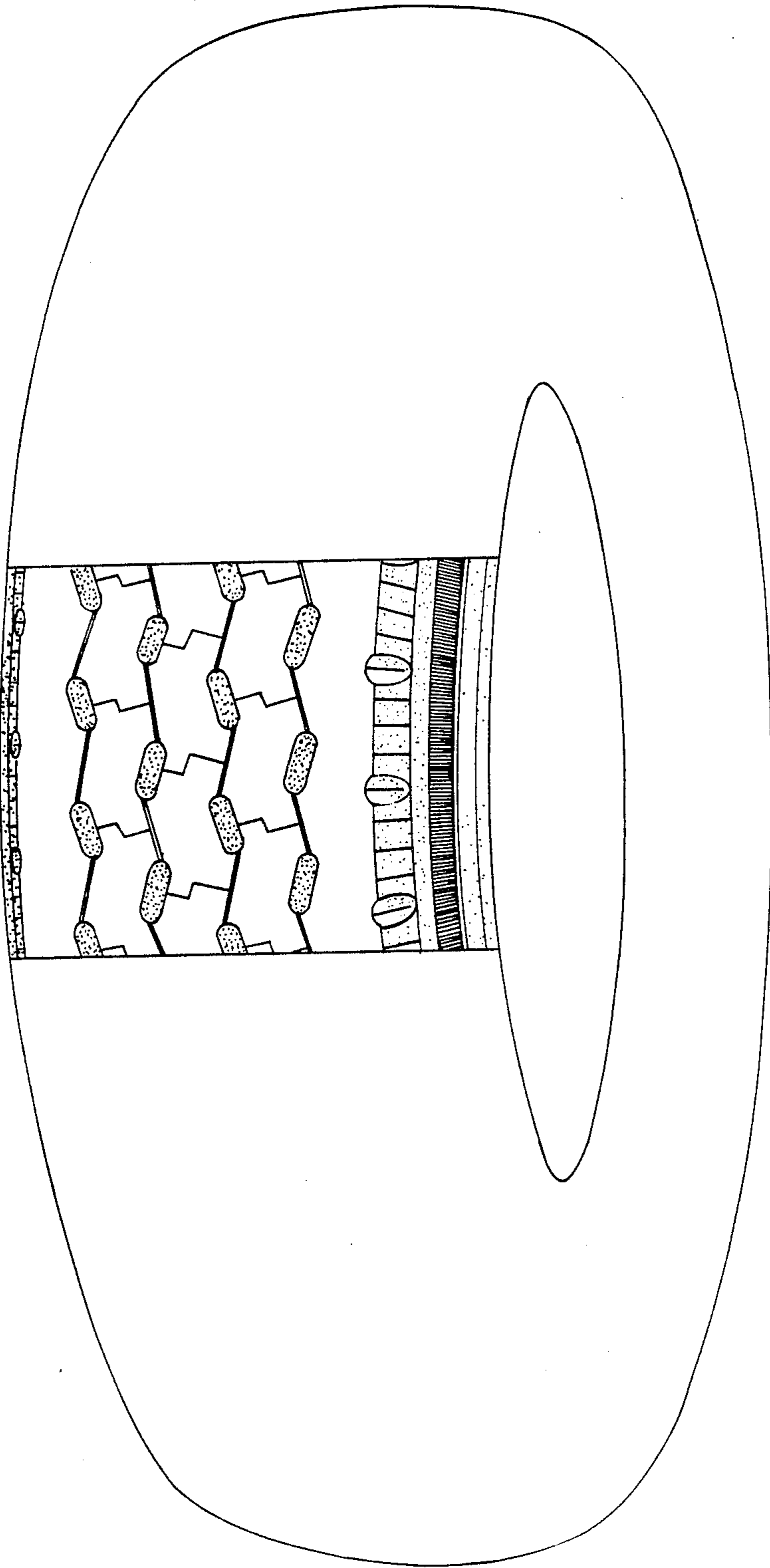

FIG 3

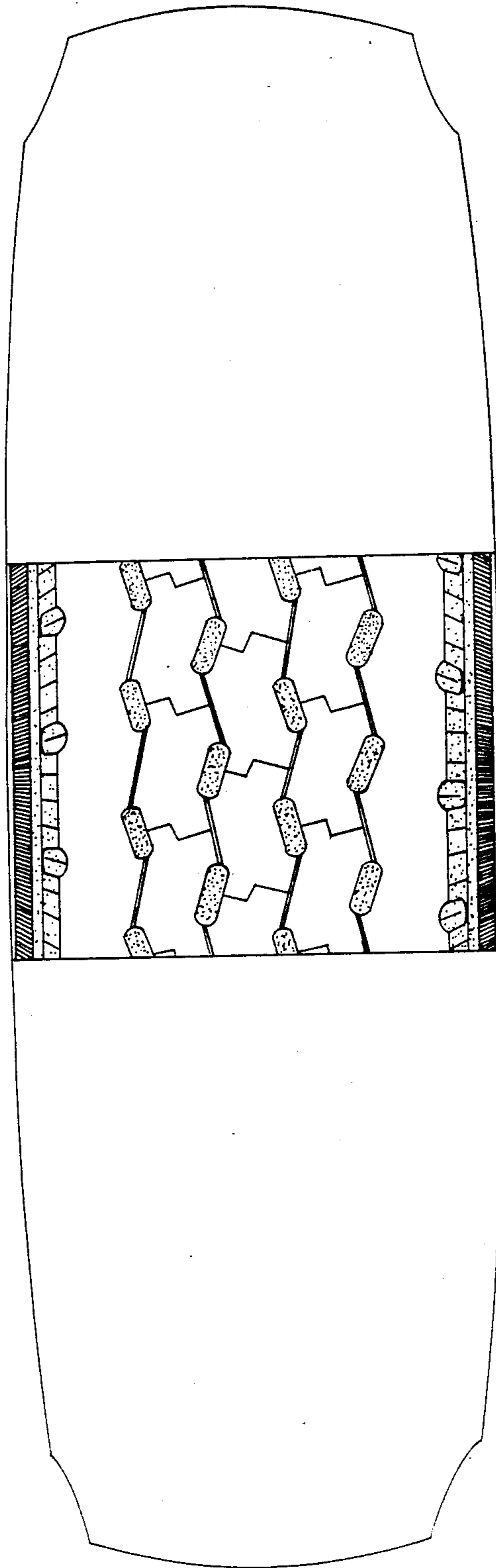

FIG 4

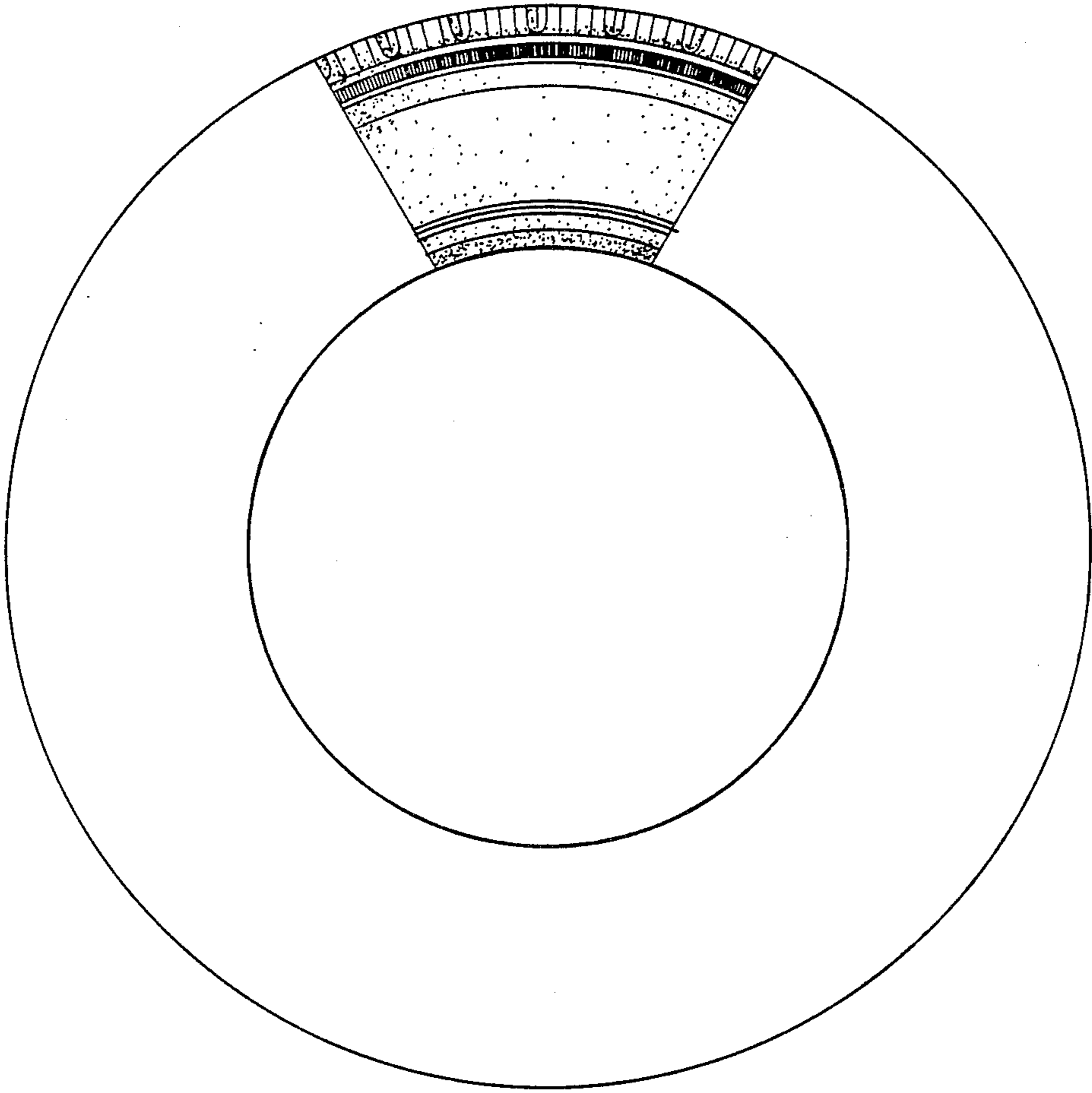

FIG 5