

[54] ELECTRONIC BALANCE

[75] Inventors: Erich Knothe, Bovenden; Hans-Heinrich Köhne, Göttingen, both of Fed. Rep. of Germany

[73] Assignee: Sartorius, GmbH, Fed. Rep. of Germany

[**] Term: 14 Years

[21] Appl. No.: 741,620

[22] Filed: Jun. 5, 1985

[52] U.S. Cl. D10/91

[58] Field of Search D10/91, 90, 94; 177/181, 238-241

[56] References Cited

U.S. PATENT DOCUMENTS

D. 165,996	2/1952	Otto	D10/90
D. 182,947	6/1958	Becker	D10/90
1,784,098	12/1930	Heusser	177/181 X
2,614,825	10/1952	Kaduec	177/181
4,465,152	8/1984	Schmitter	177/238 X
4,664,207	5/1987	Knothe	177/238 X

FOREIGN PATENT DOCUMENTS

461121 10/1968 Switzerland 177/238

Primary Examiner—Nelson C. Holtje
Attorney, Agent, or Firm—Eric P. Schellin

[57] CLAIM

The ornamental design for an electronic balance, as shown and described.

DESCRIPTION

FIG. 1 is a left front perspective view of an electronic balance showing our new design;
 FIG. 2 is a left front perspective view thereof with the access doors open;
 FIG. 3 is a front elevational view thereof;
 FIG. 4 is a left side elevational view thereof, the right side being a mirror image thereof;
 FIG. 5 is a top plan view thereof;
 FIG. 6 is a bottom plan view thereof;
 FIG. 7 is a left front perspective view of a second embodiment of our new design of FIGS. 1-6;

FIG. 8 is a left front perspective view thereof with the access doors open;
 FIG. 9 is a front elevational view thereof;
 FIG. 10 is a left side elevational view thereof, the right side being a mirror image thereof;
 FIG. 11 is a top plan view thereof;
 FIG. 12 is a bottom plan view thereof;
 FIG. 13 is a left front perspective view of a third embodiment of our new design of FIGS. 1-6;
 FIG. 14 is a left front perspective view thereof with the access doors open;
 FIG. 15 is a front elevational view thereof;
 FIG. 16 is a left side elevational view thereof, the right side being a mirror image thereof;
 FIG. 17 is a top plan view thereof;
 FIG. 18 is a bottom plan view thereof;
 FIG. 19 is a left front perspective view of a fourth embodiment of our new design of FIGS. 1-6;
 FIG. 20 is a left front perspective view thereof with the access doors open;
 FIG. 21 is a front elevational view thereof;
 FIG. 22 is a left side elevational view thereof, the right side being a mirror image thereof;
 FIG. 23 is a top plan view thereof;
 FIG. 24 is a bottom plan view thereof;
 FIG. 25 is a left front perspective view of a fifth embodiment of our new design of FIGS. 1-6;
 FIG. 26 is a left front perspective view thereof with the access doors open;
 FIG. 27 is a front elevational view thereof;
 FIG. 28 is a left side elevational view thereof, the right side being a mirror image thereof;
 FIG. 29 is a top plan view thereof;
 FIG. 30 is a bottom plan view thereof;
 FIG. 31 is a left front perspective view of a sixth embodiment of our new design of FIGS. 1-6;
 FIG. 32 is a left front perspective view thereof with the access doors open;
 FIG. 33 is a front elevational view thereof;
 FIG. 34 is a left side elevational view thereof, the right side being a mirror image thereof;
 FIG. 35 is a top plan view thereof;
 FIG. 36 is a bottom plan view thereof;
 FIG. 37 is a left front perspective view of a seventh embodiment of our new design of FIGS. 1-6;

(Continued on next page.)

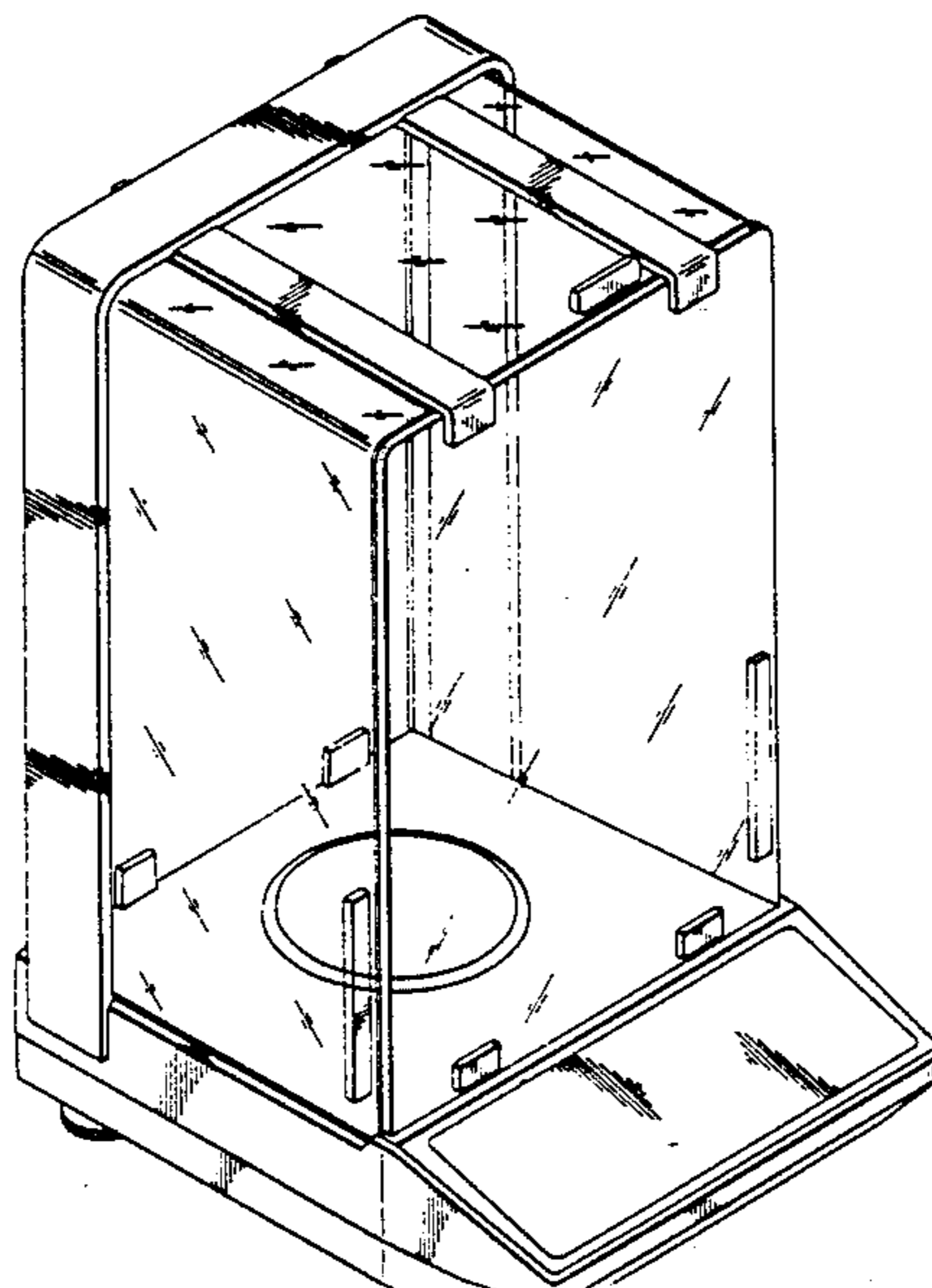

FIG. 38 is a left front perspective view thereof with the access doors open;

FIG. 39 is a front elevational view thereof;

FIG. 40 is a left side elevational view thereof, the right side being a mirror image thereof;

FIG. 41 is a top plan view thereof;

FIG. 42 is a bottom plan view thereof;

FIG. 43 is a left front perspective view of a eighth embodiment of our new design of FIGS. 1-6;

FIG. 44 is a left front perspective view thereof with the access doors open;

FIG. 45 is a front elevational view thereof;

FIG. 46 is a left side elevational view thereof, the right side being a mirror image thereof;

FIG. 47 is a top plan view thereof;

FIG. 48 is a bottom plan view thereof;

FIG. 49 is a left front perspective view of a ninth embodiment of our new design of FIGS. 1-6;

FIG. 50 is a left front perspective view thereof with the access doors open;

FIG. 51 is a front elevational view thereof;

FIG. 52 is a left side elevational view thereof, the right side being a mirror image thereof;

FIG. 53 is a top plan view thereof;

FIG. 54 is a bottom plan view thereof.

Fig. 1

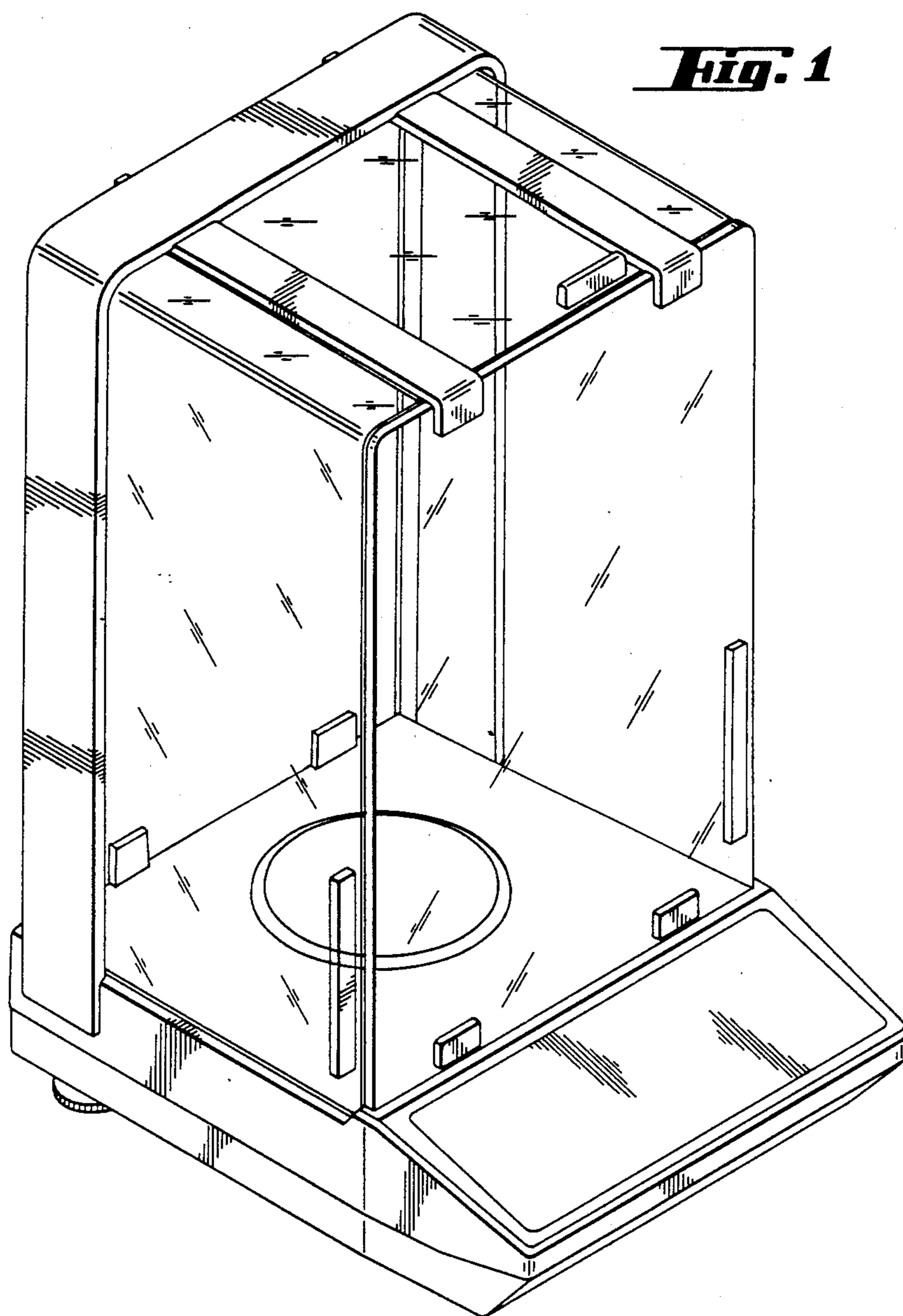

Fig. 2

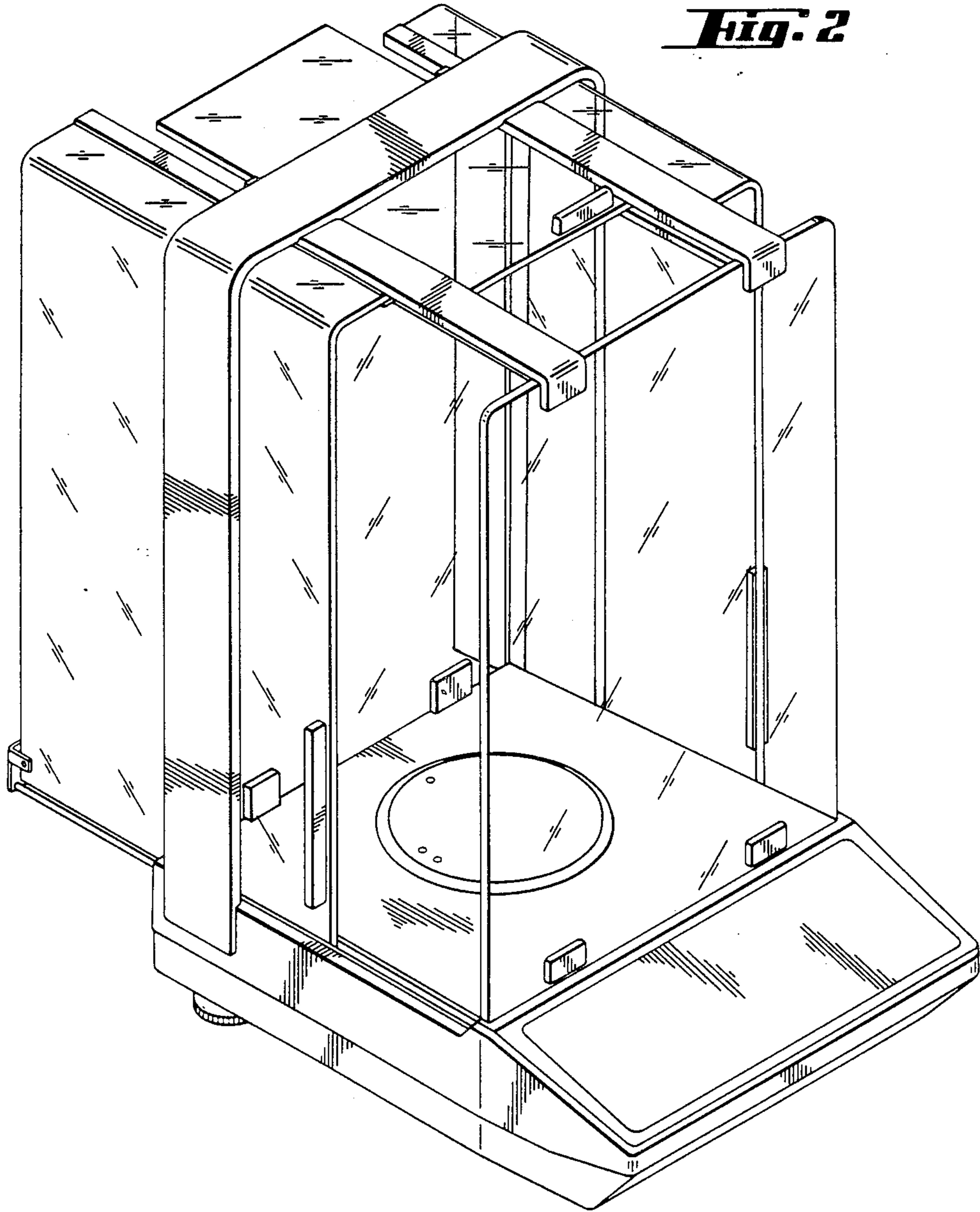

Fig. 3

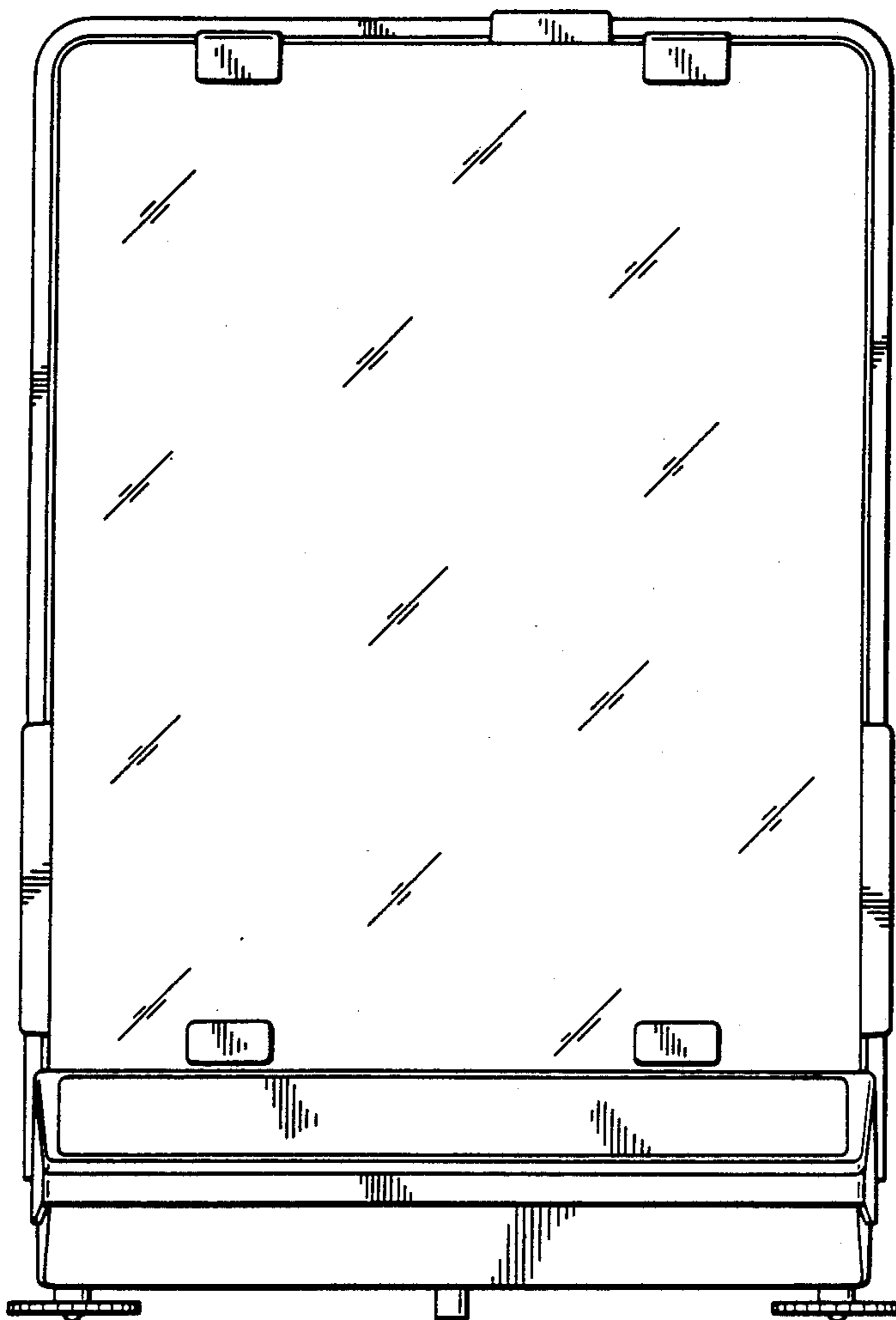

Fig. 4

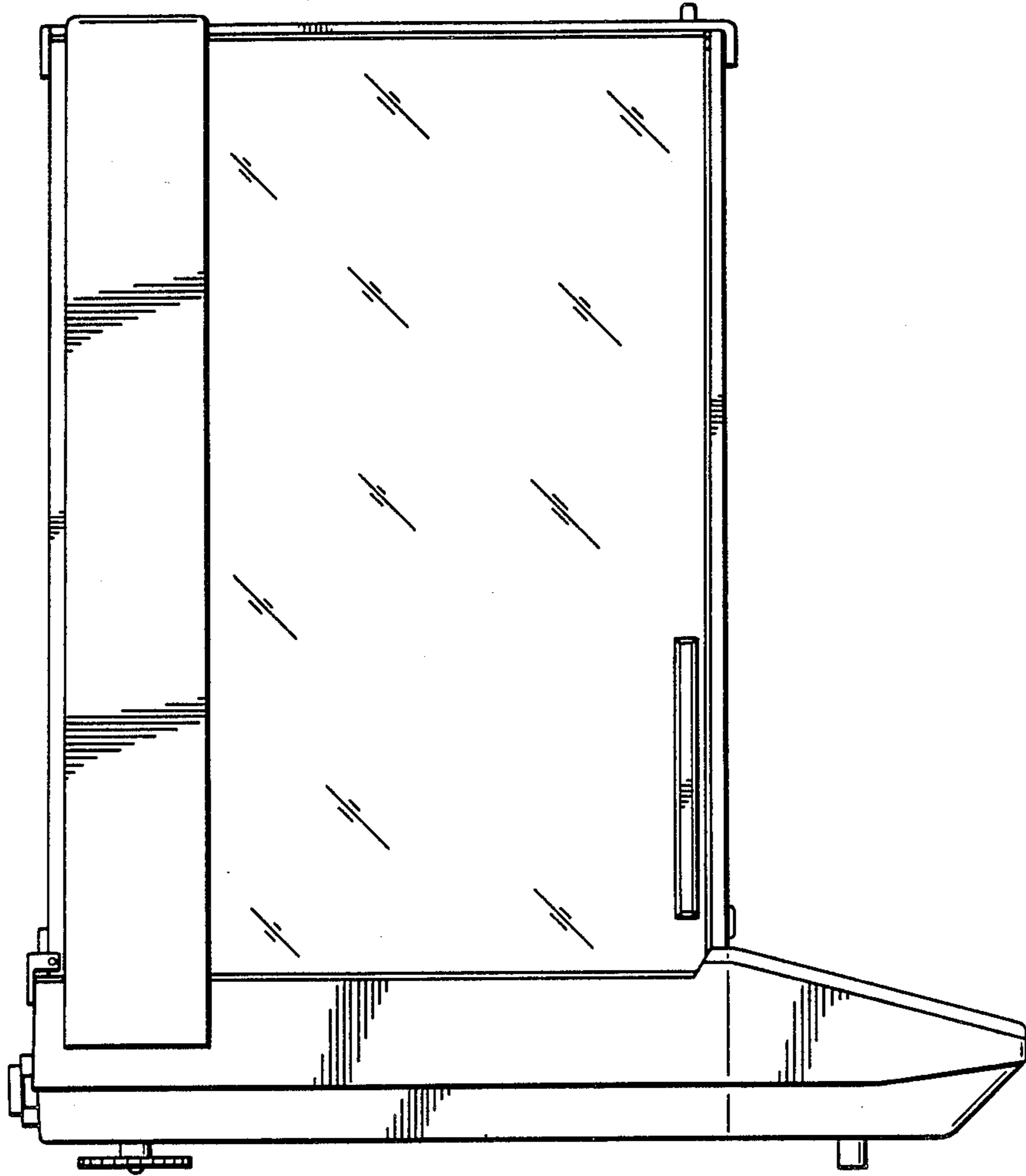

Fig. 5

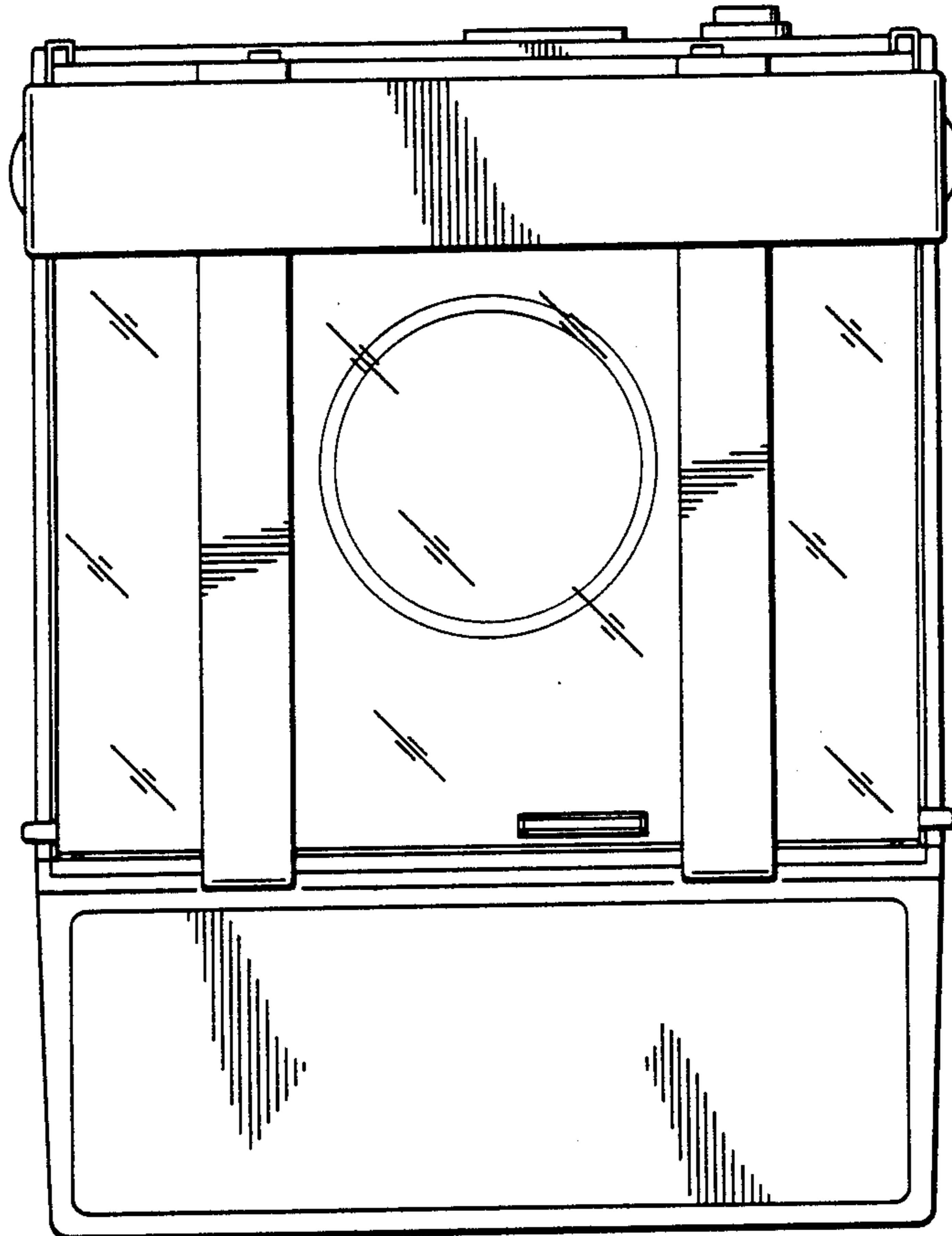

Fig. 6

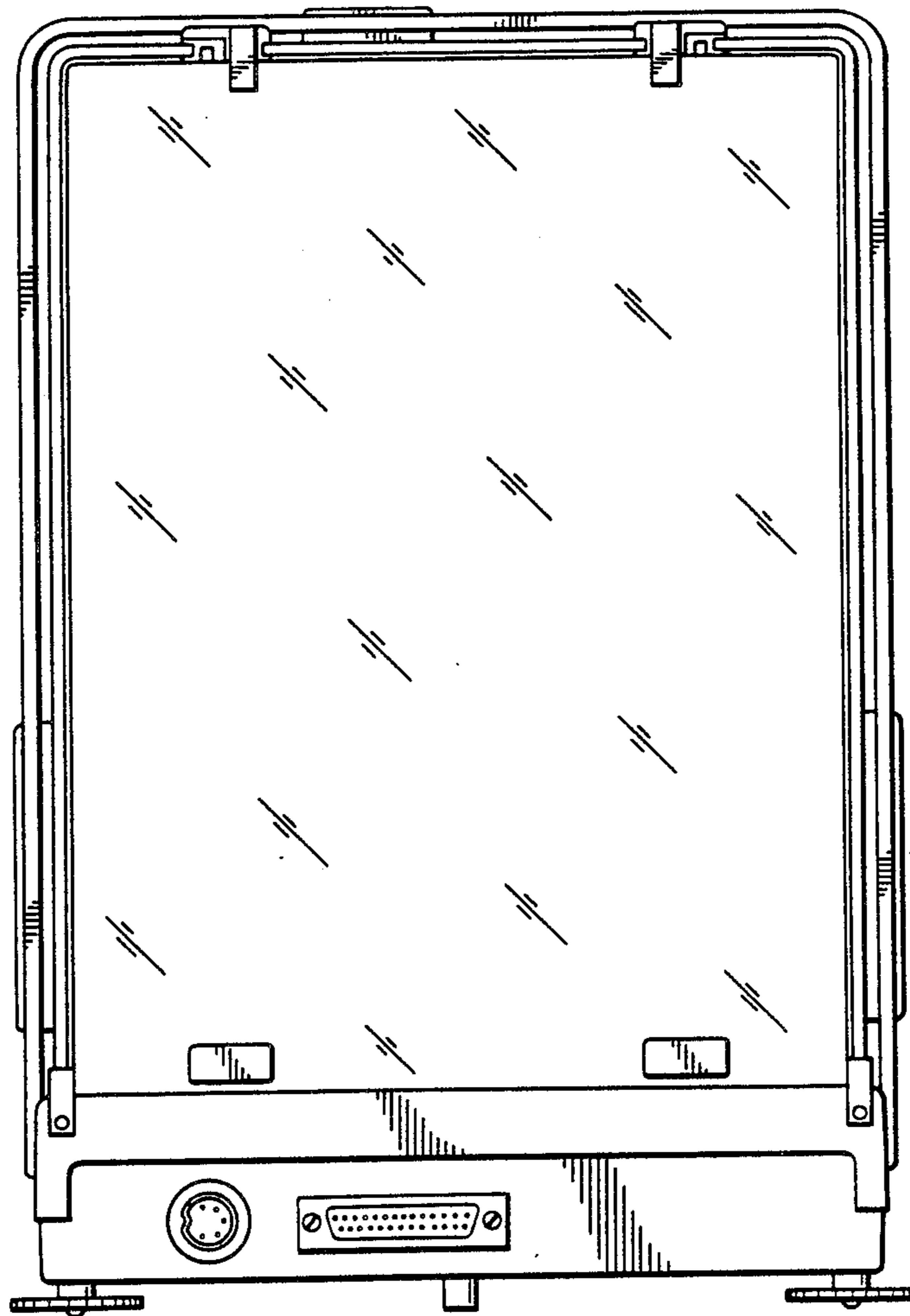
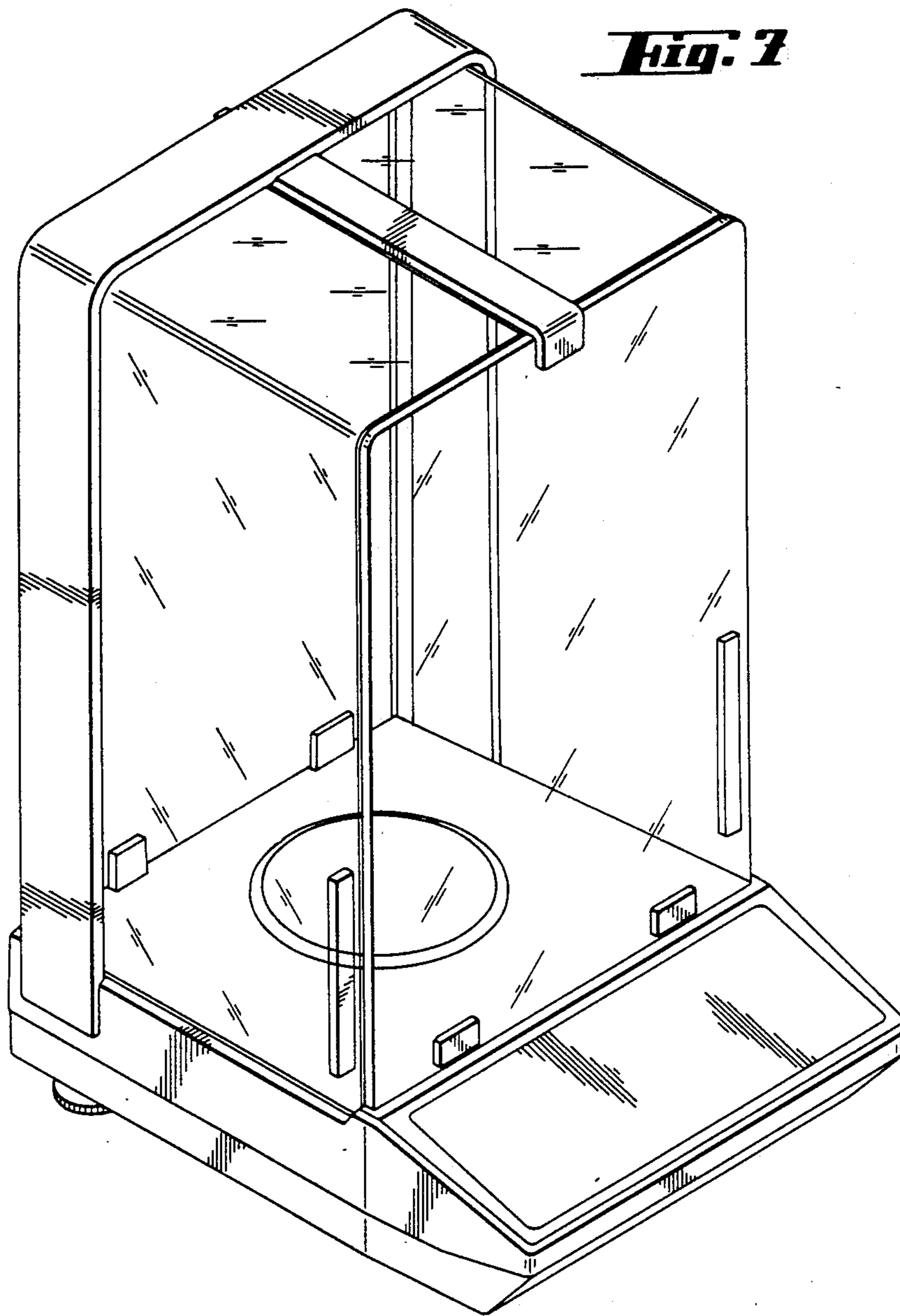

Fig. 7



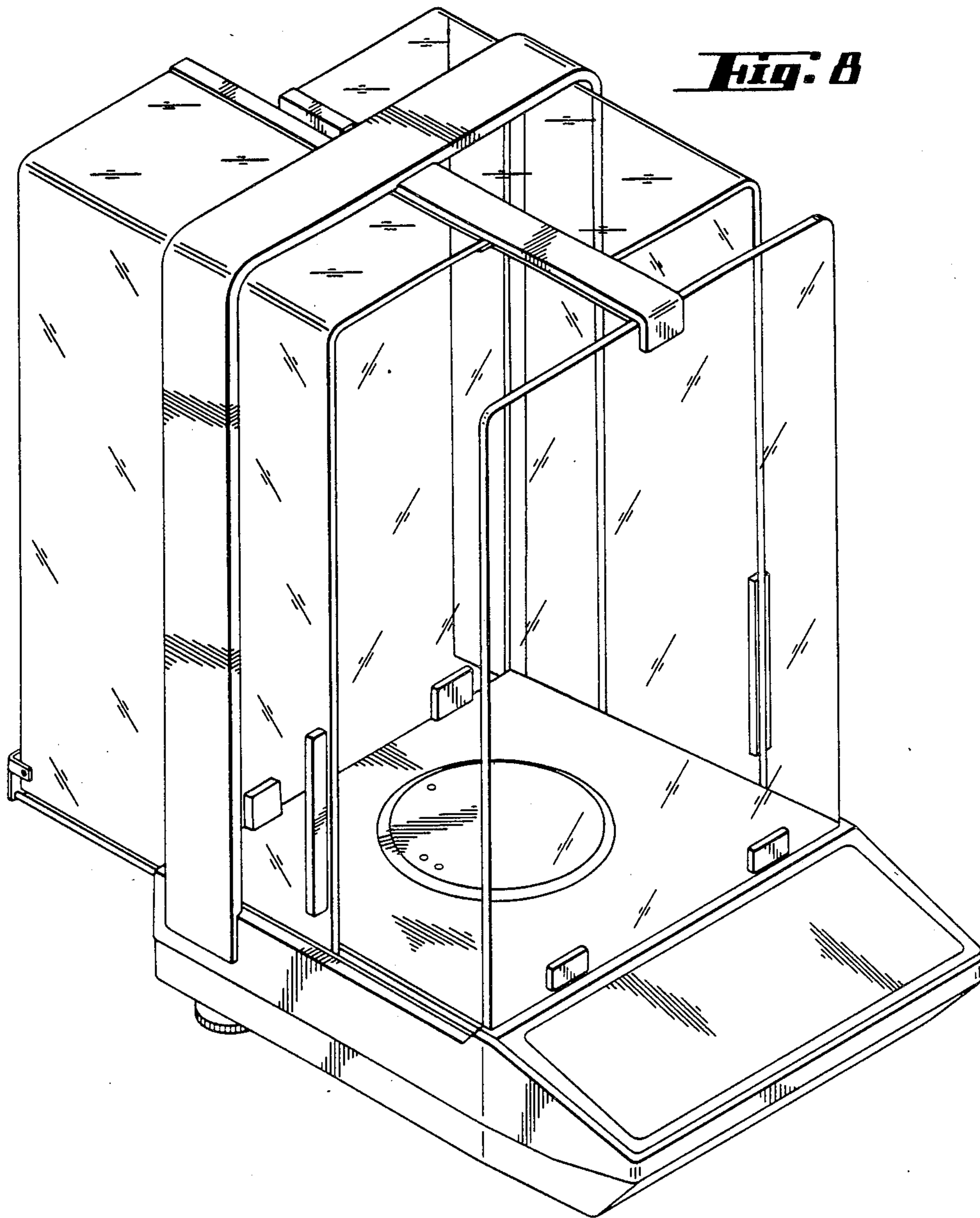

Fig. 9

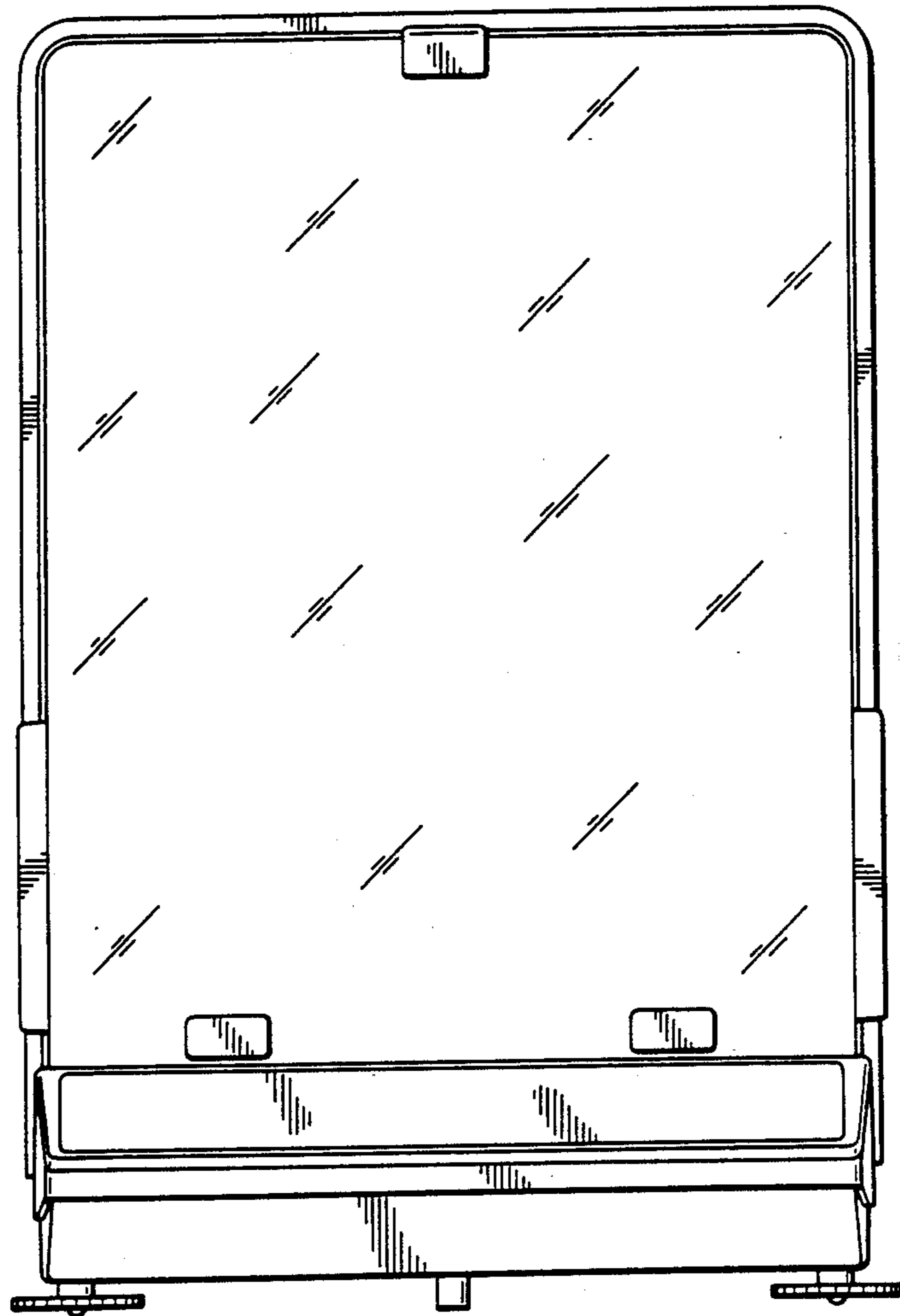

Fig. 10

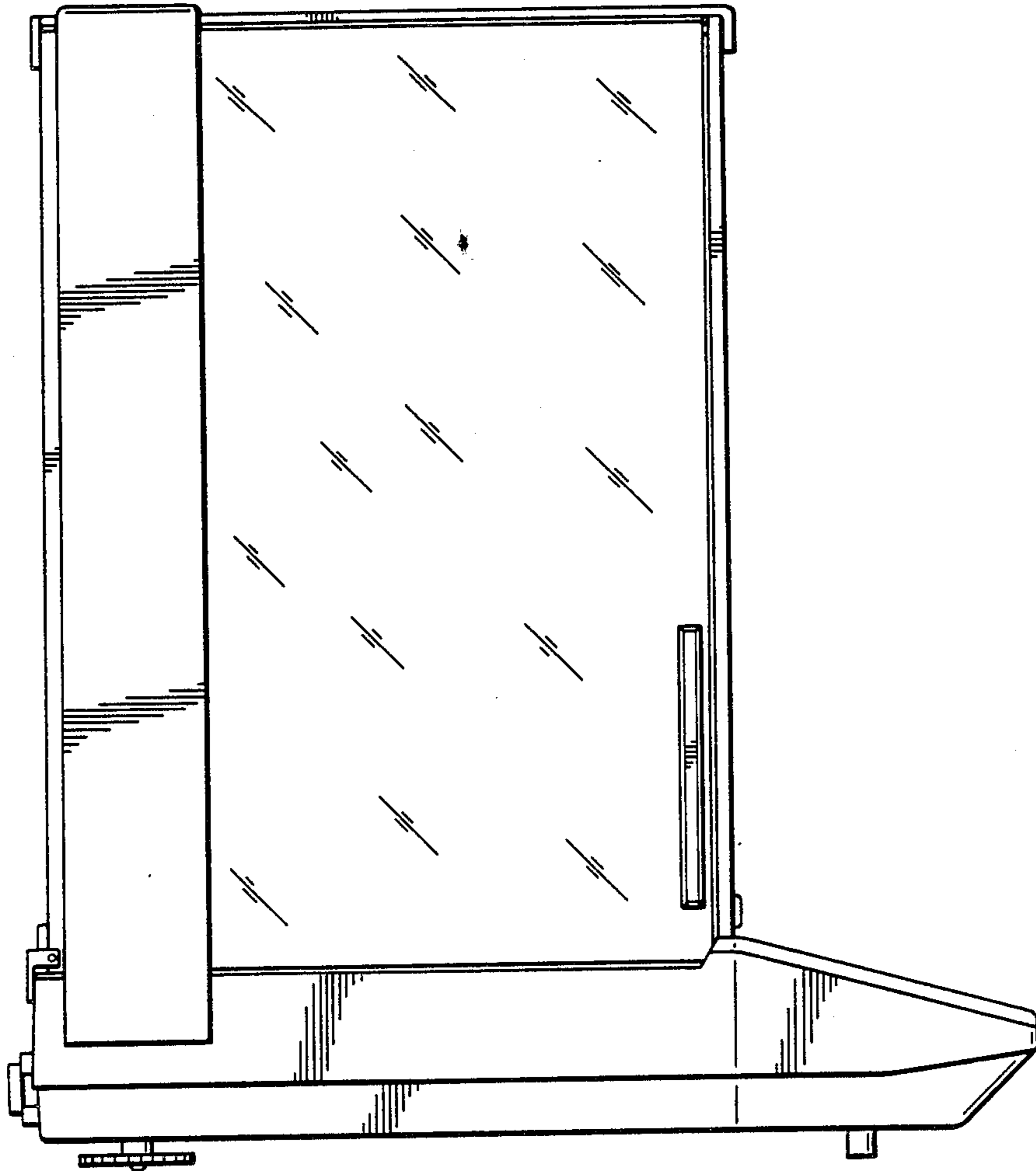

Fig. 11

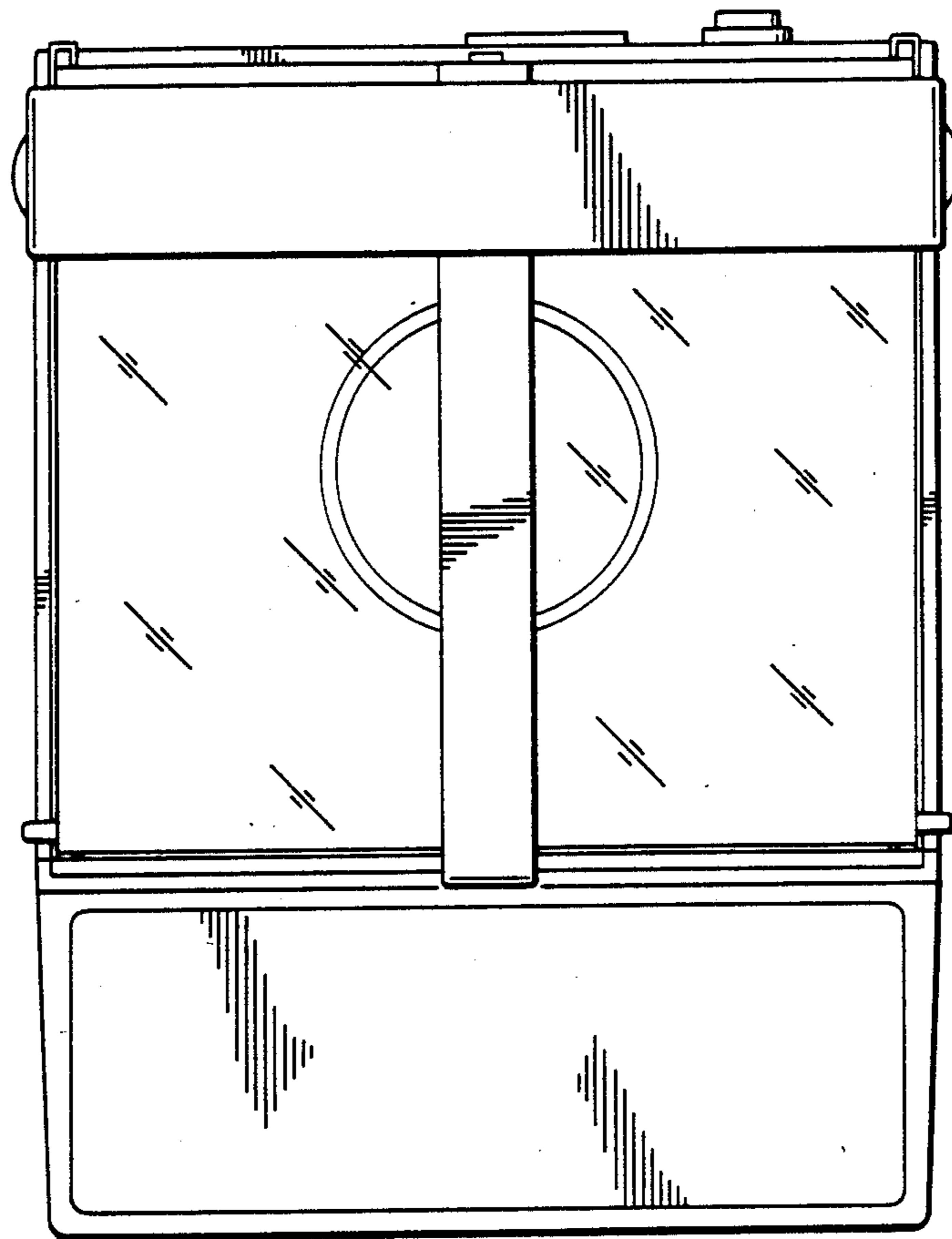

Fig. 12

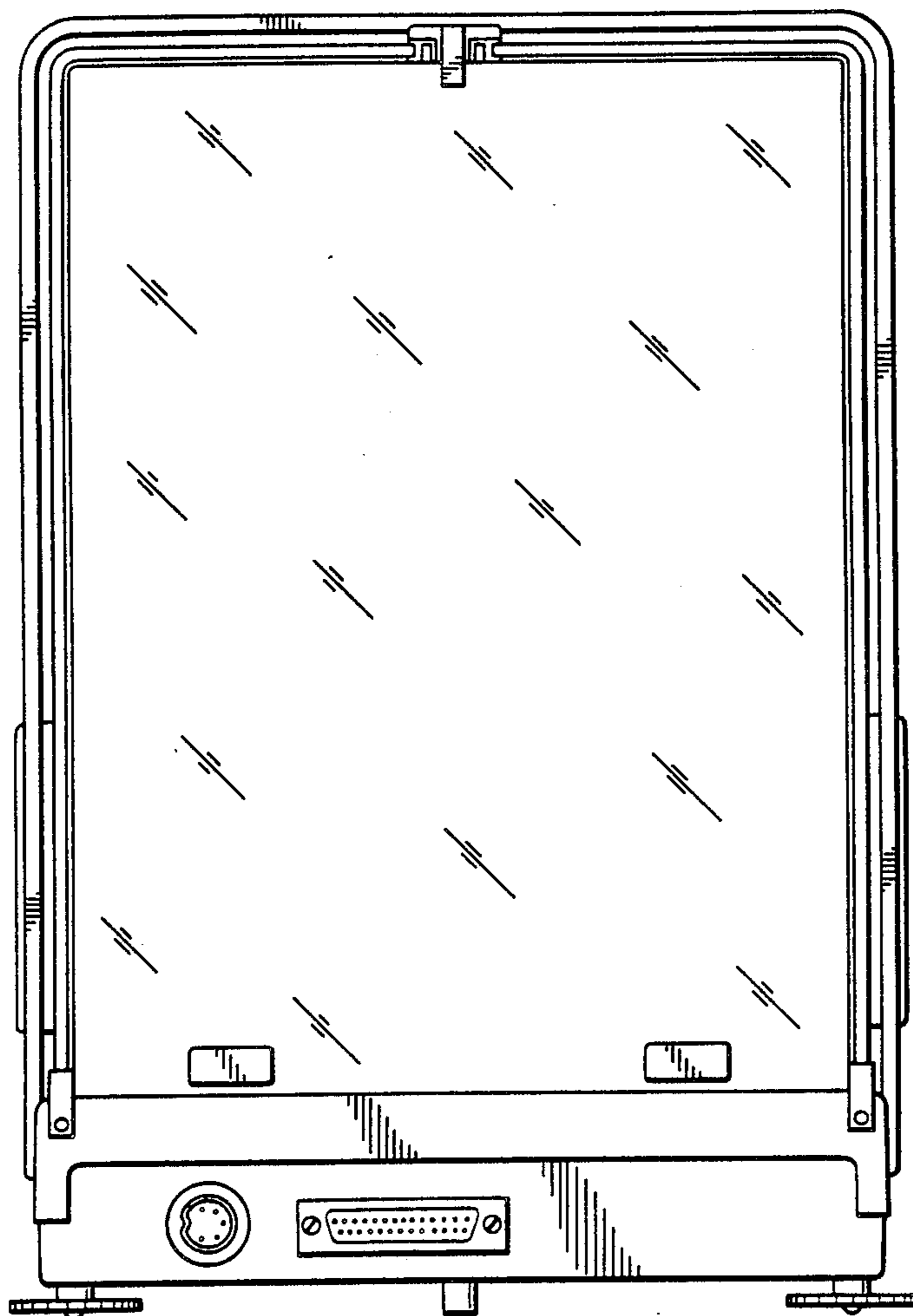

Fig. 13

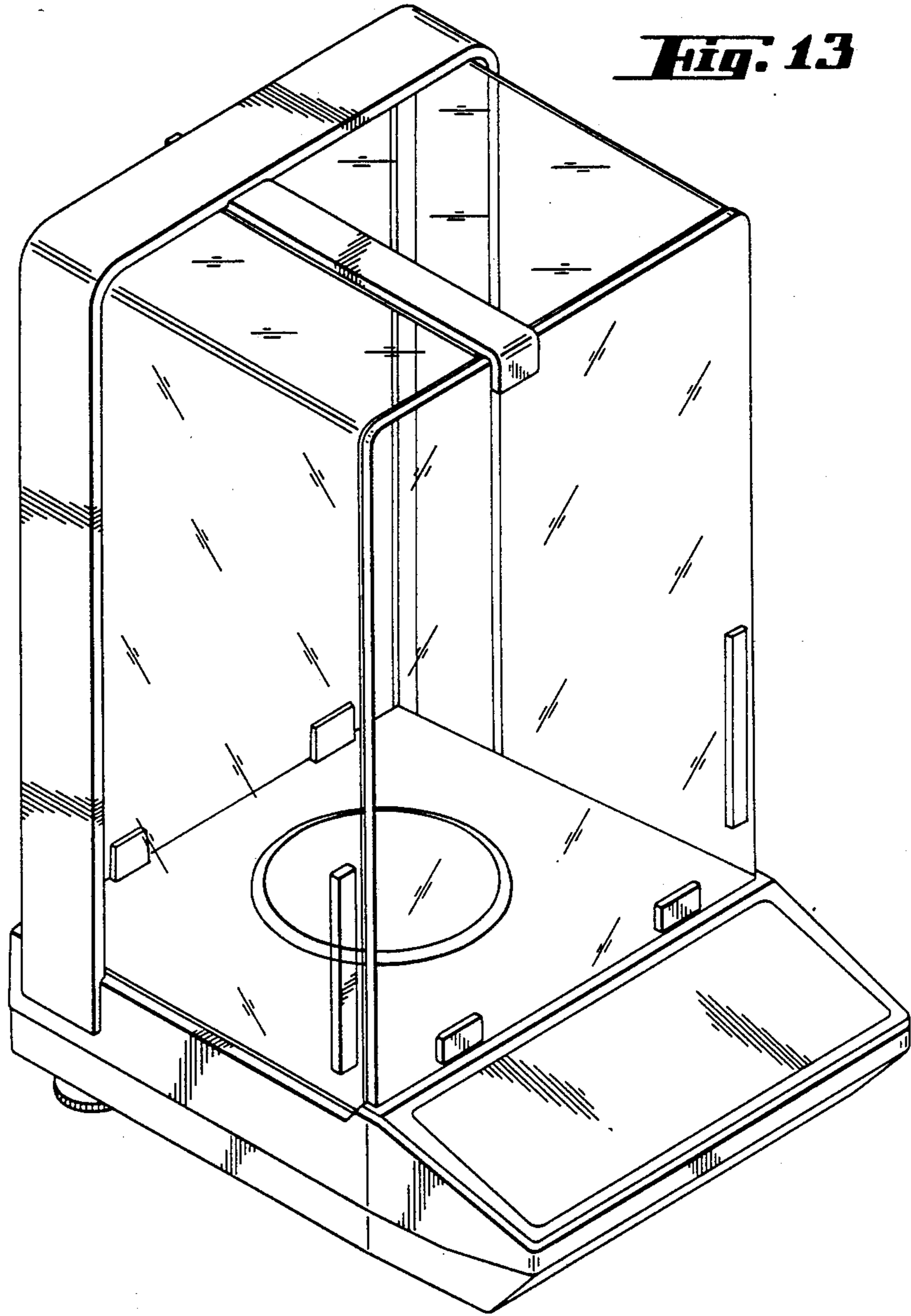

Fig. 14

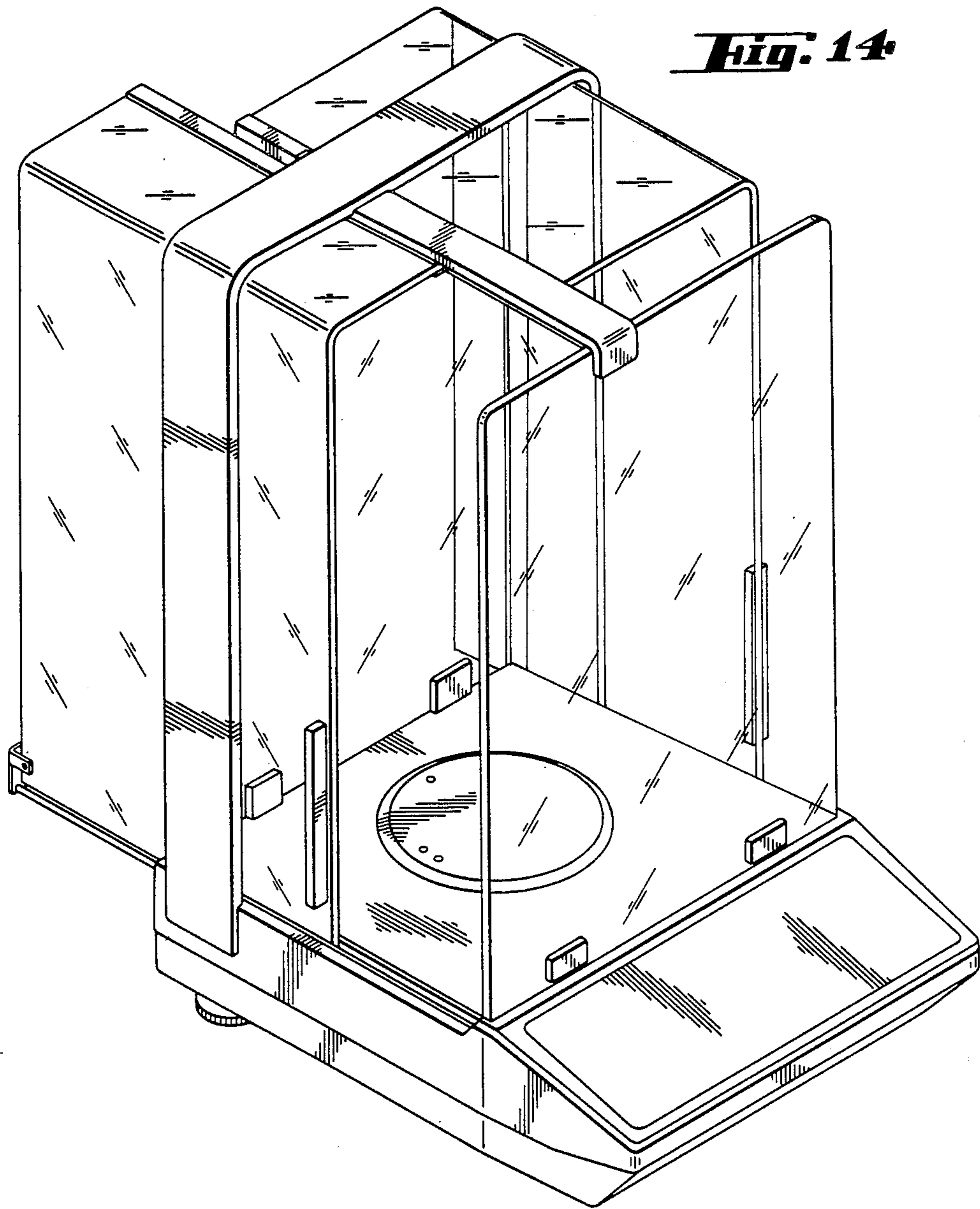

Fig. 15

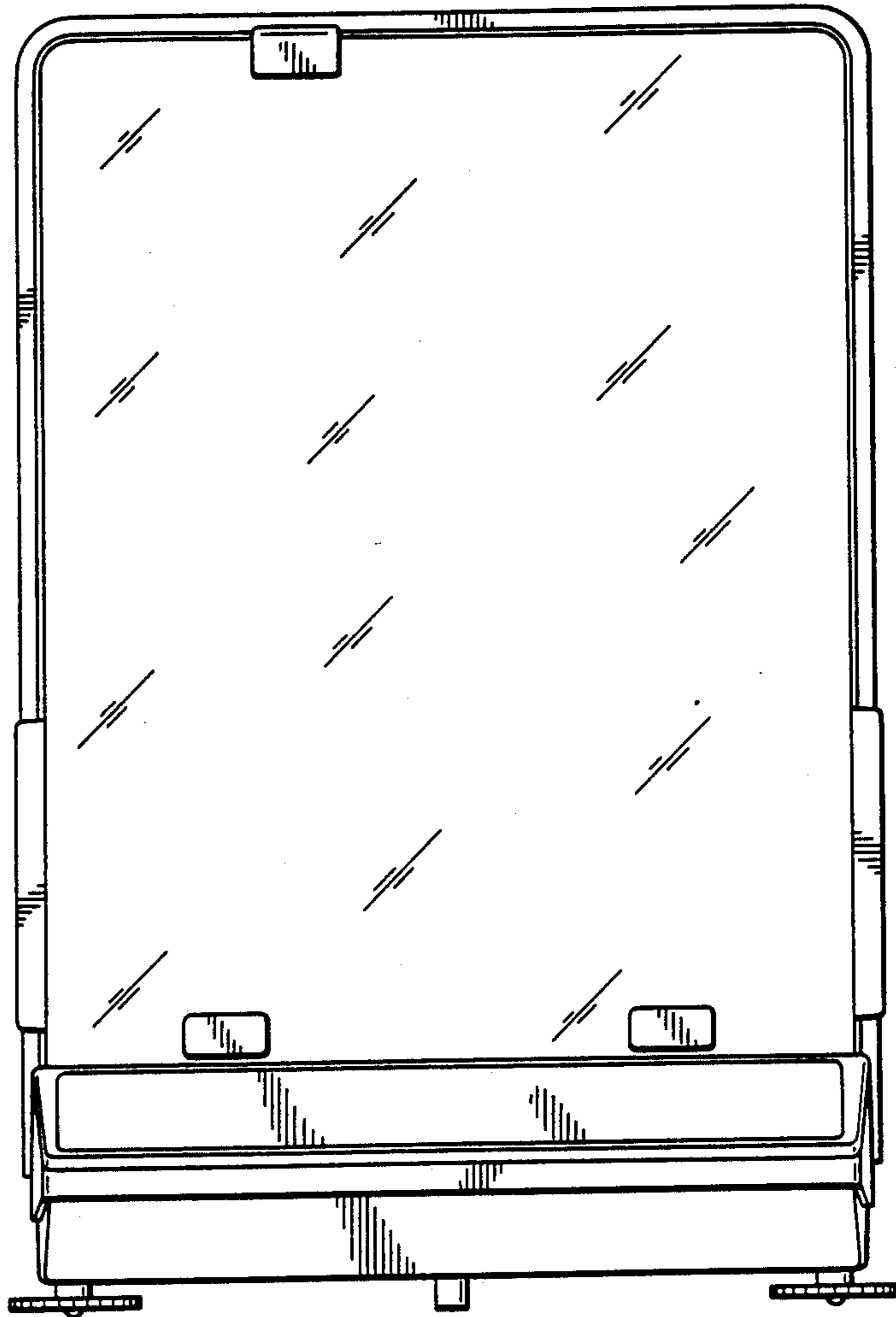

Fig. 16

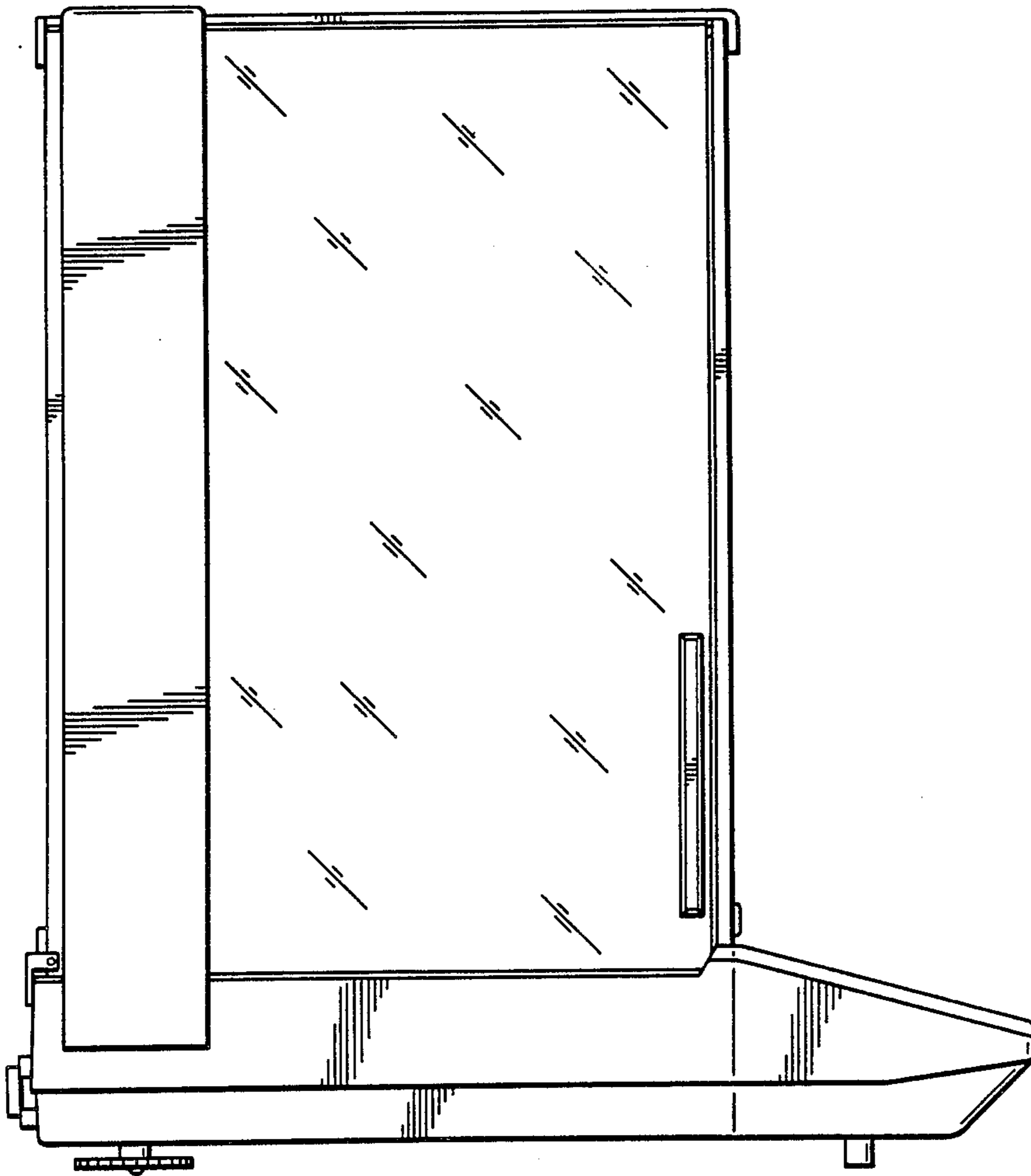

Fig. 17

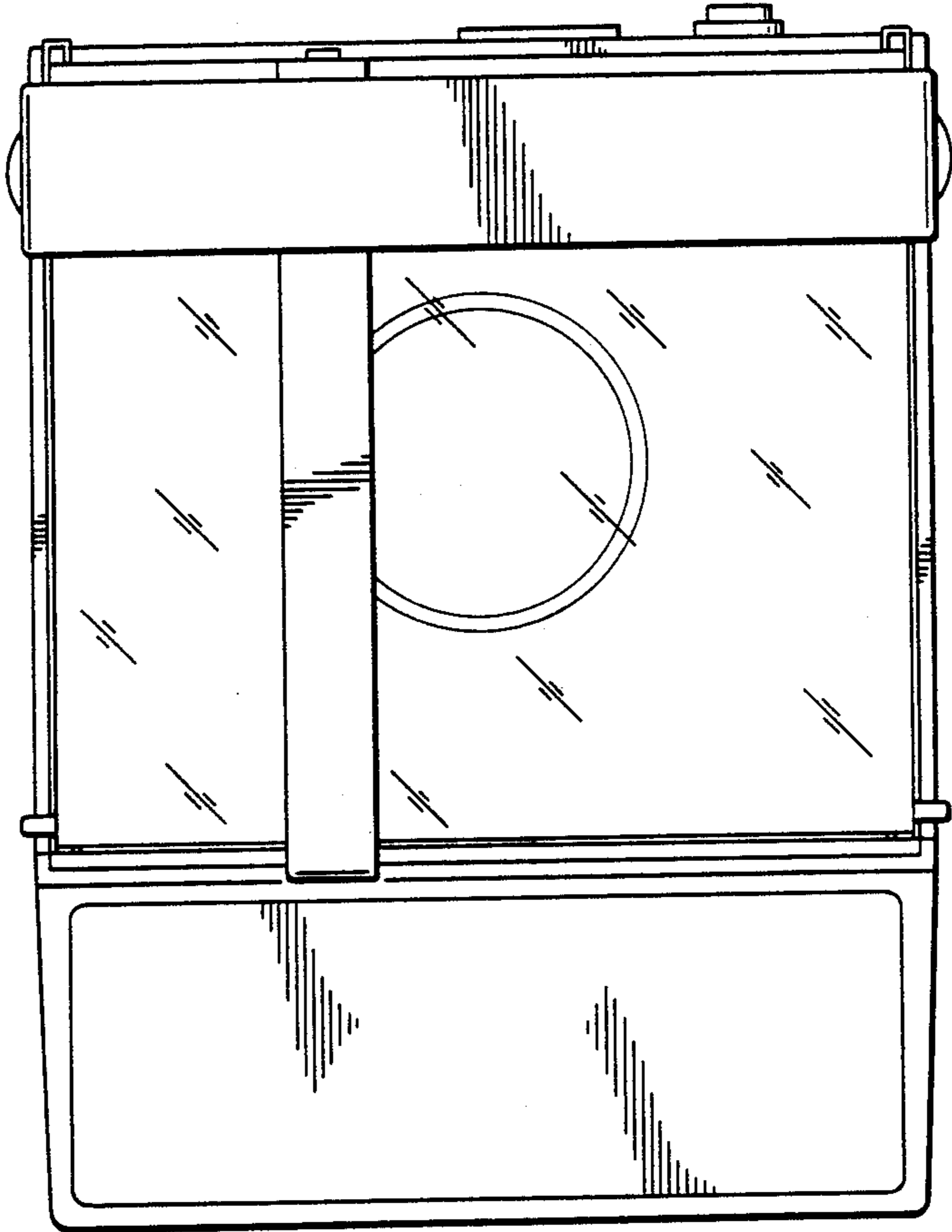
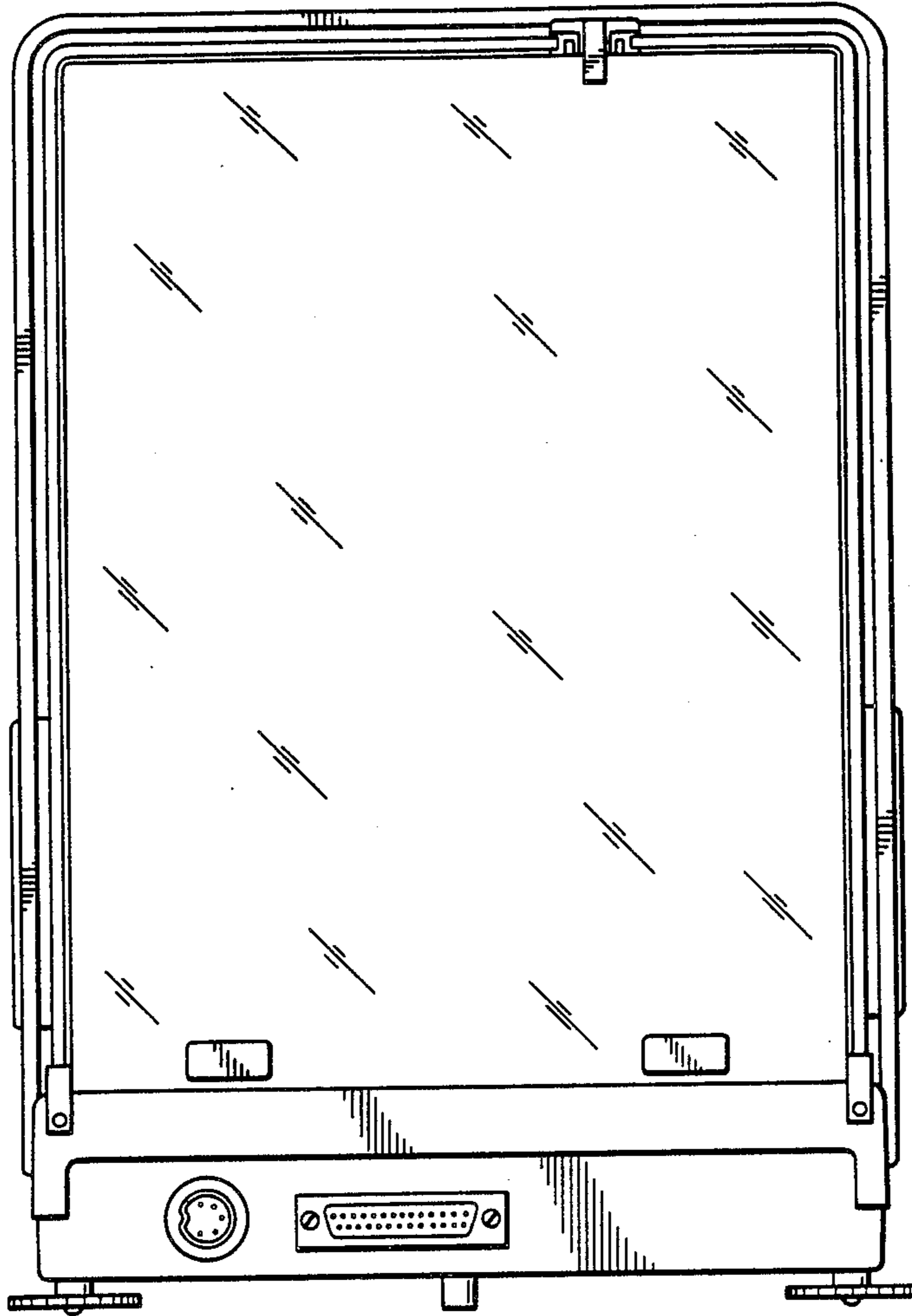

Fig. 1A



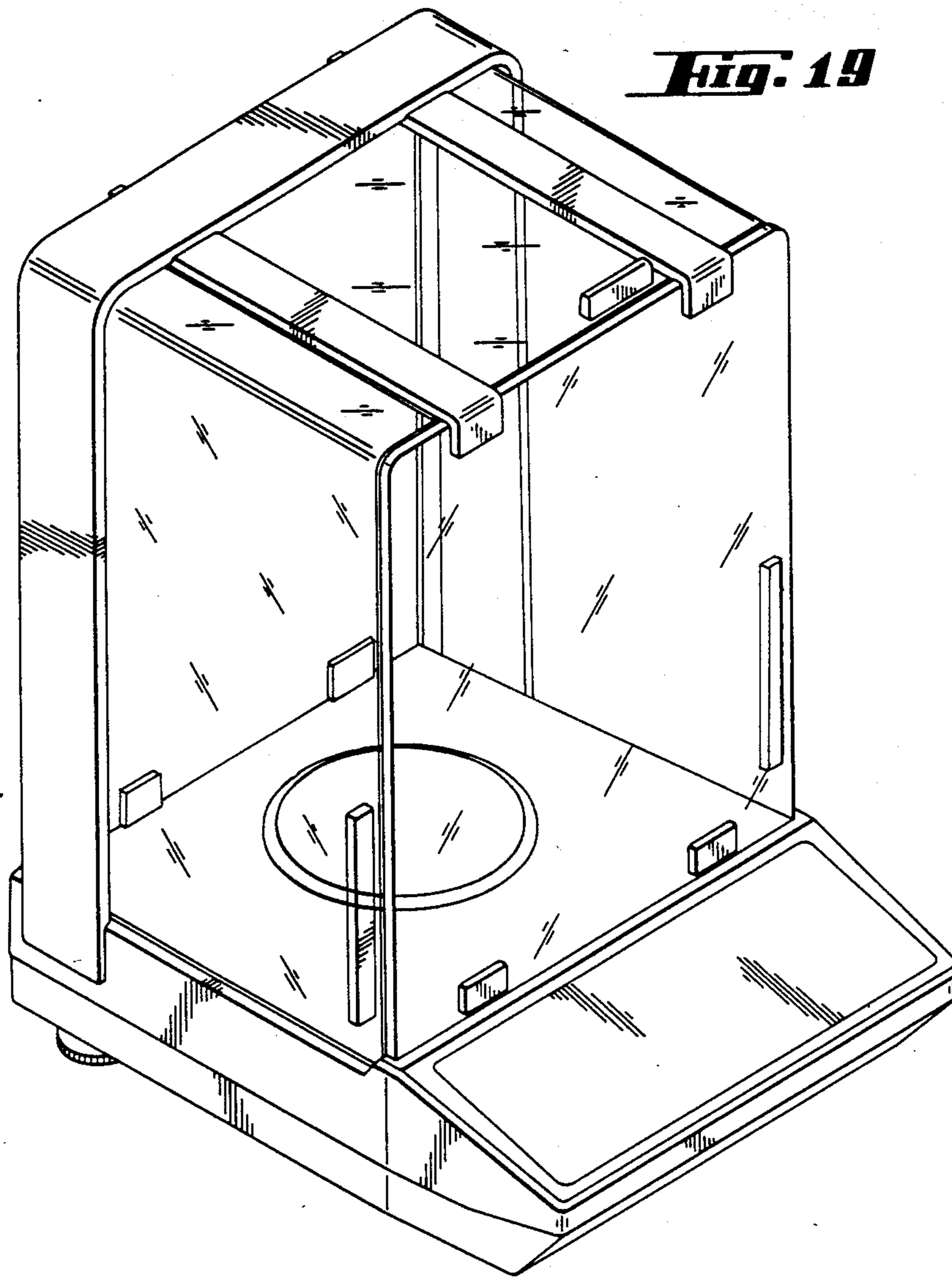

Fig. 20

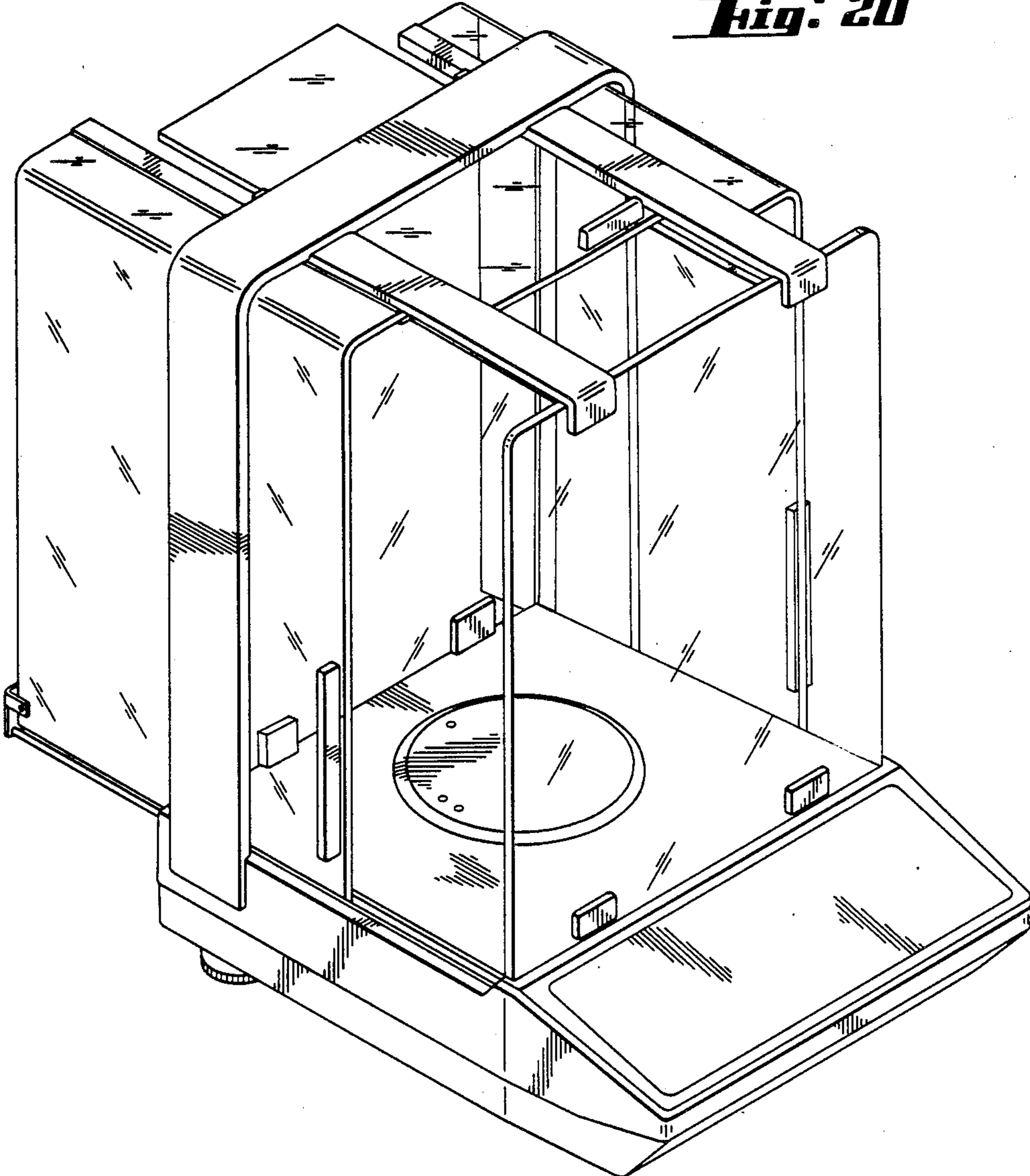

Fig. 21

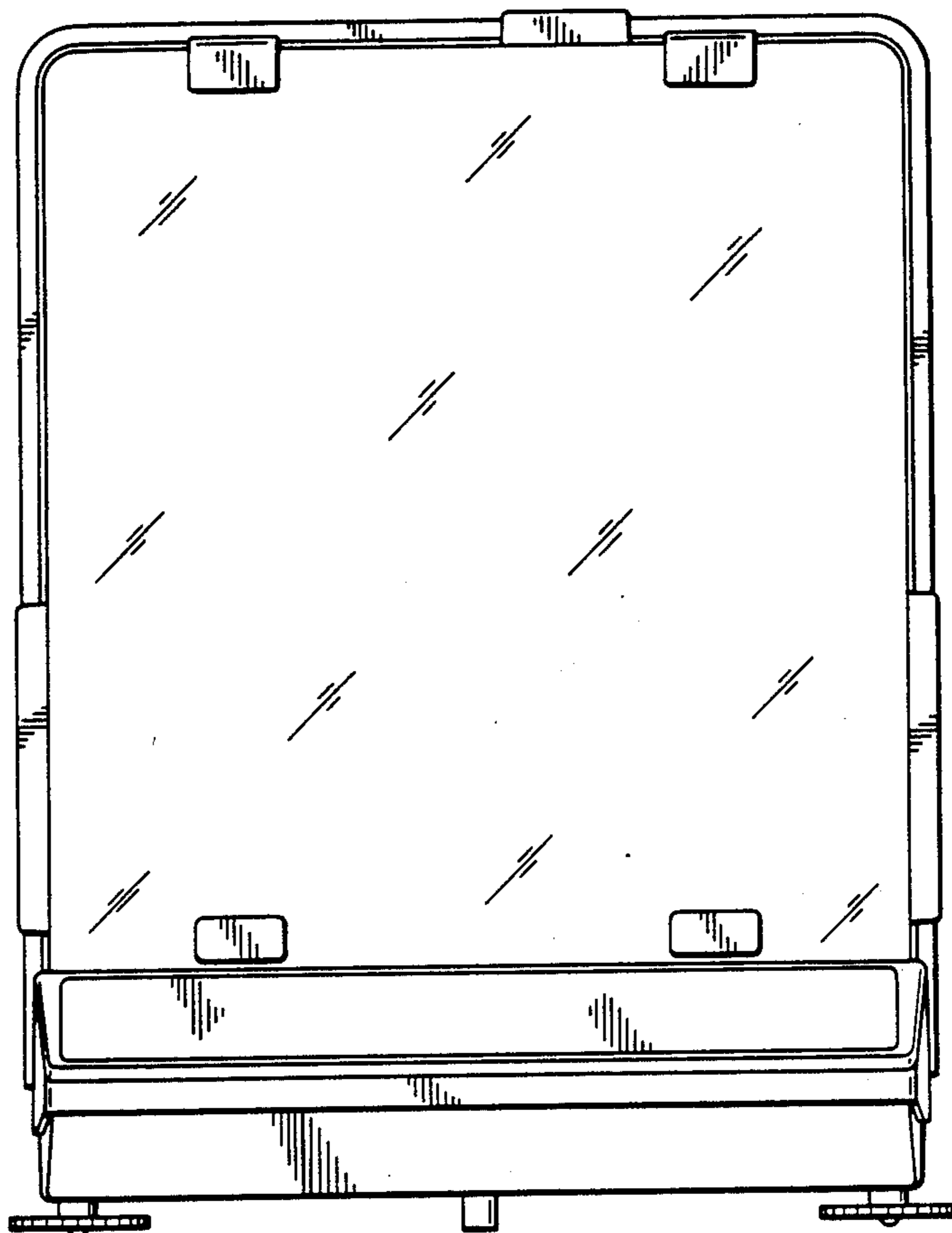

Fig. 22

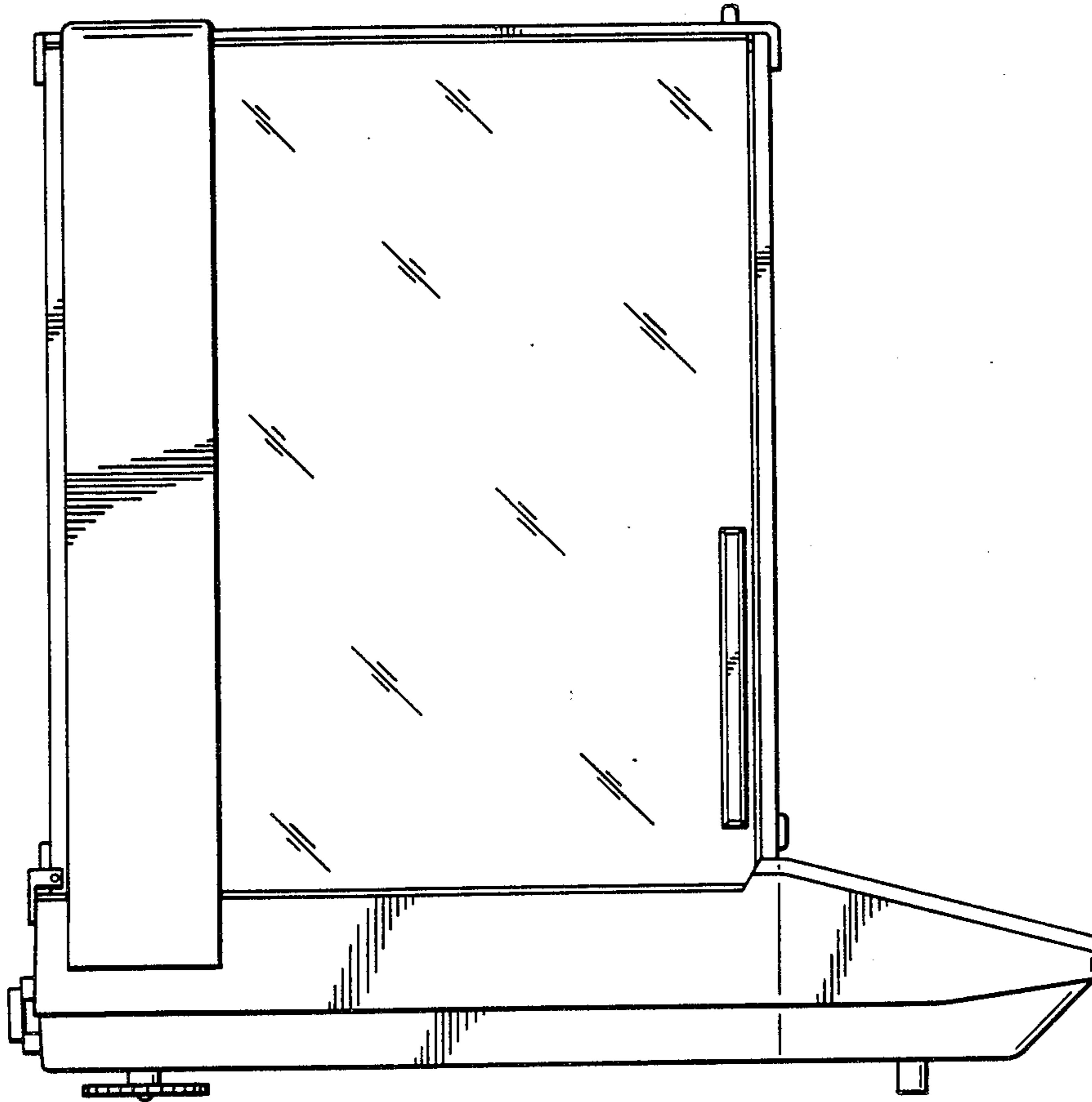

Fig. 23

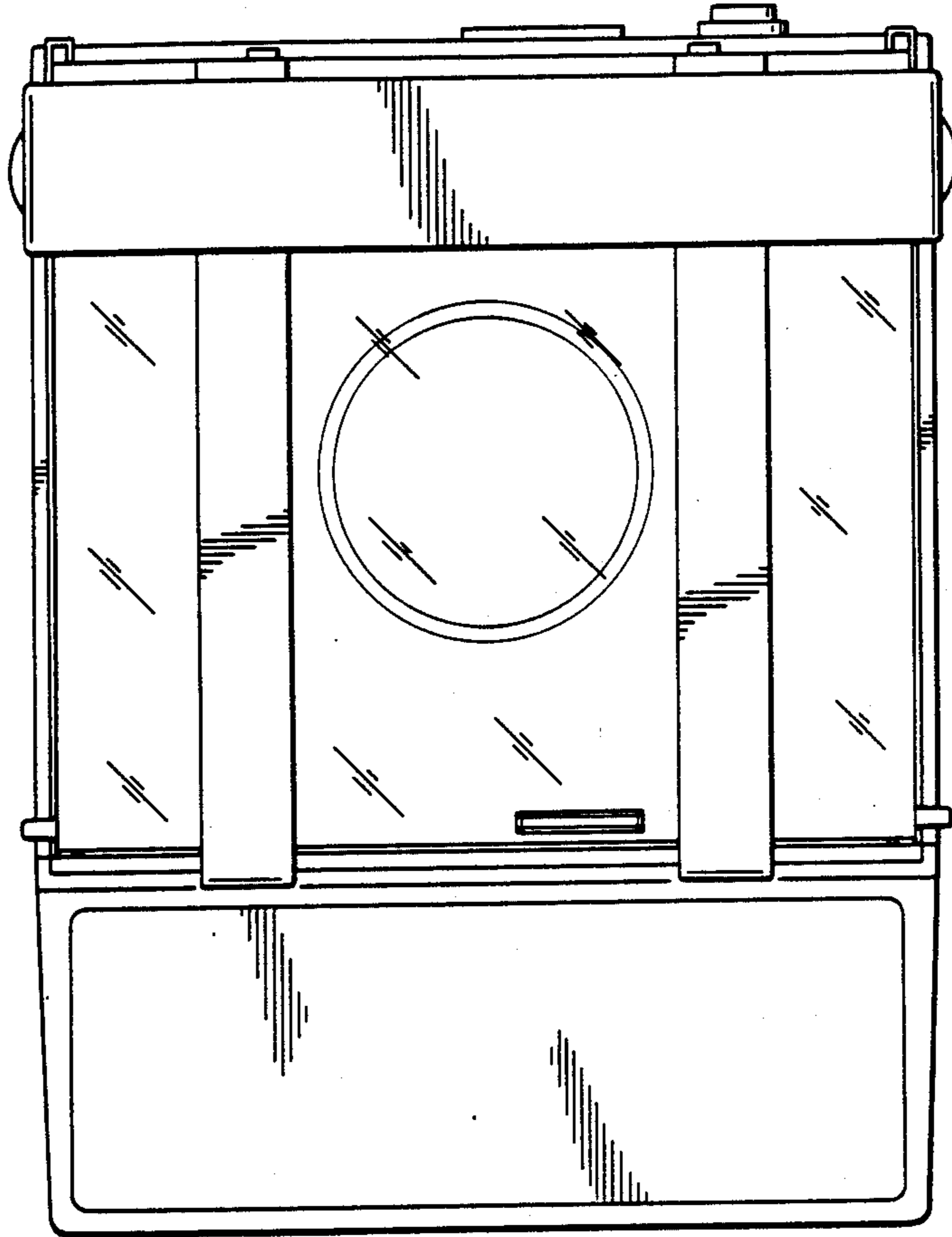

Fig. 24

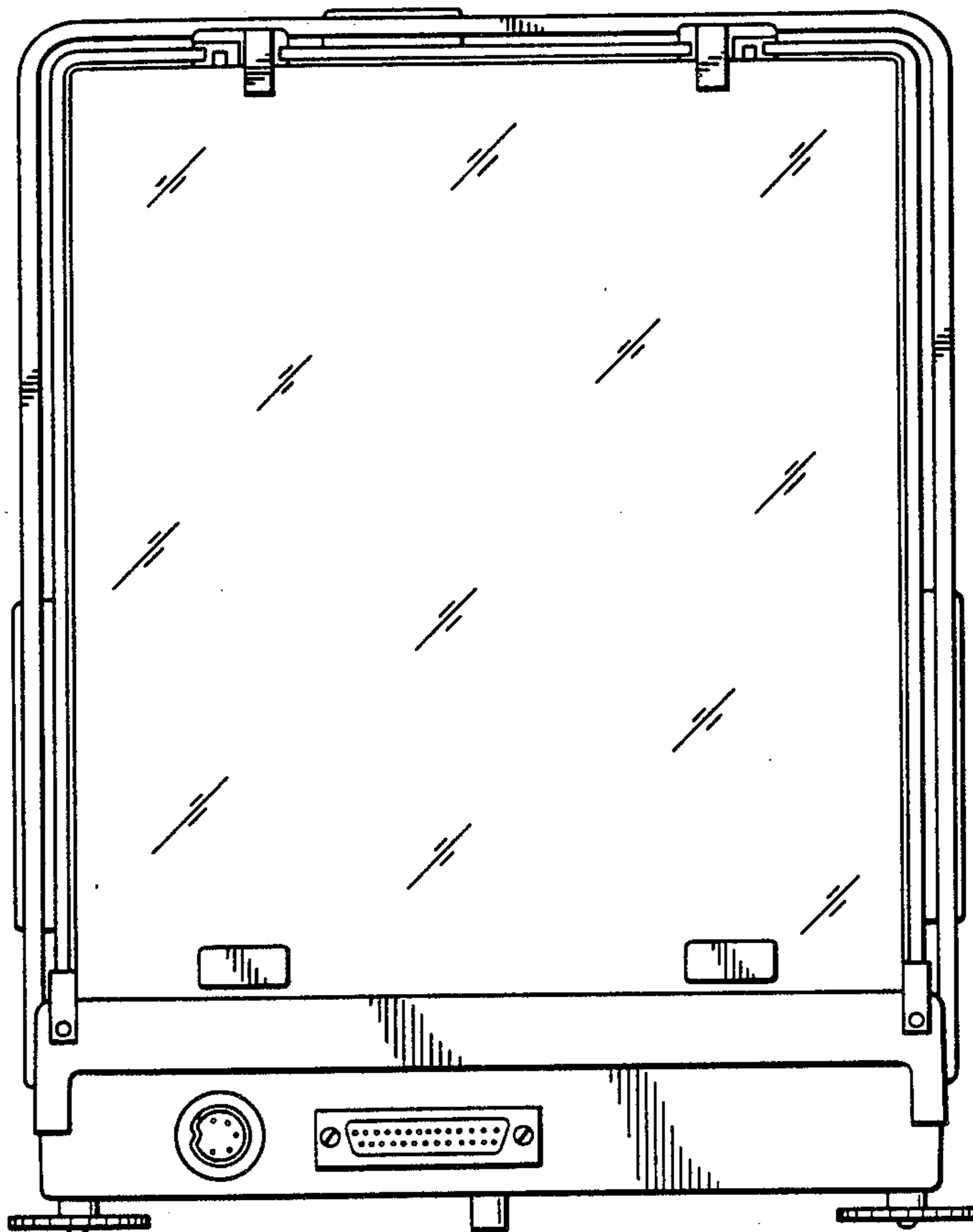
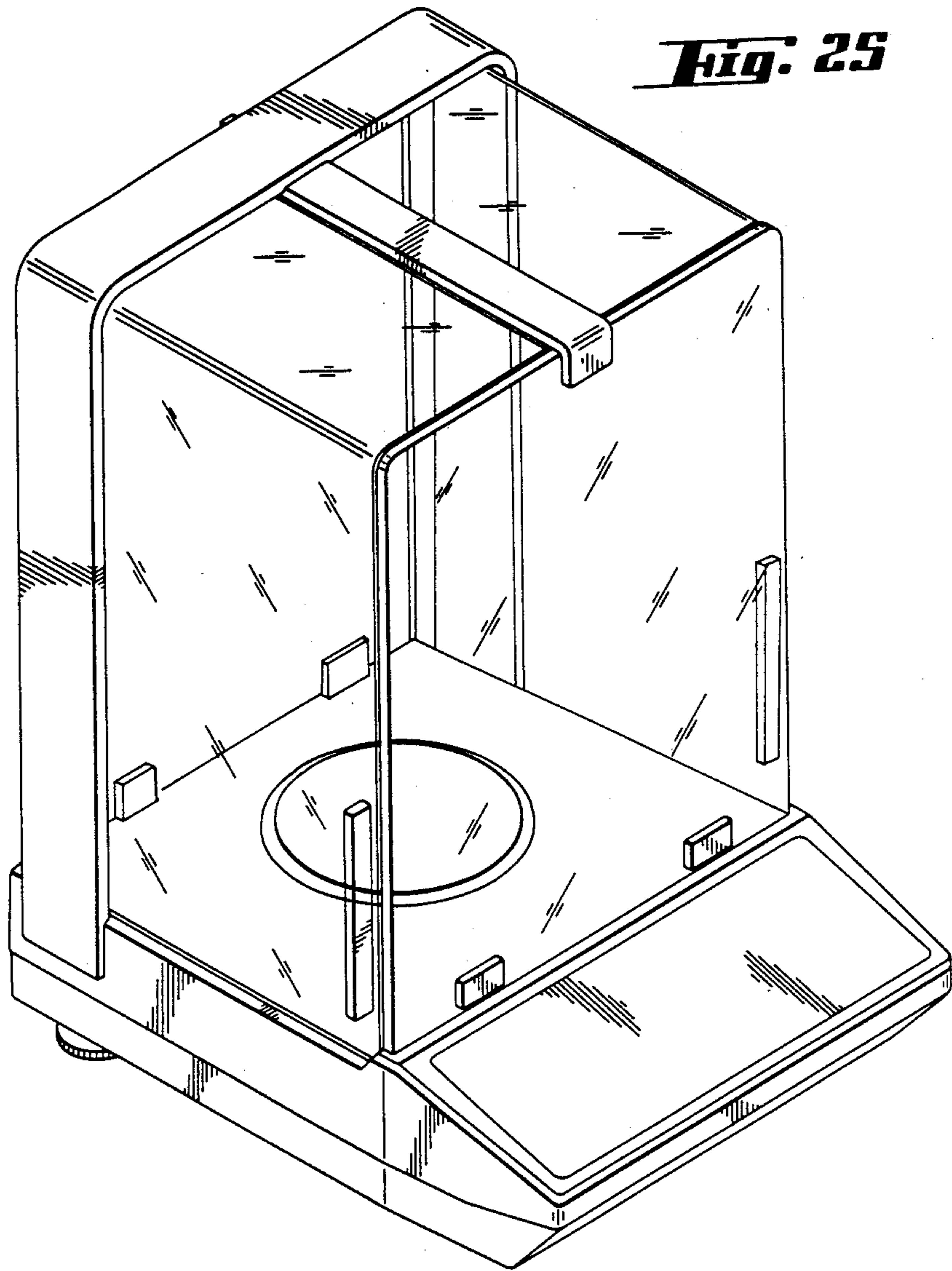

Fig. 25



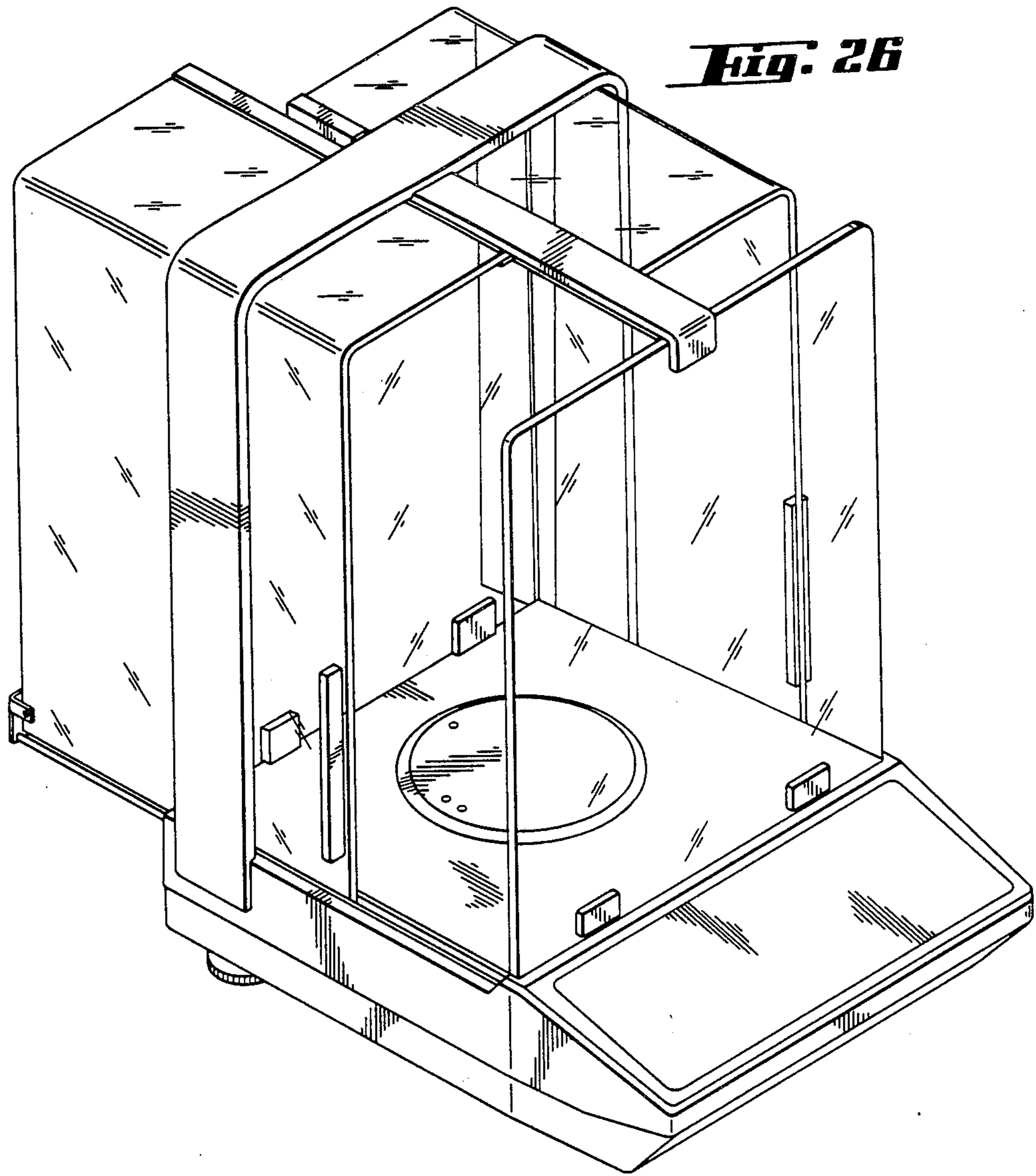

Fig. 27

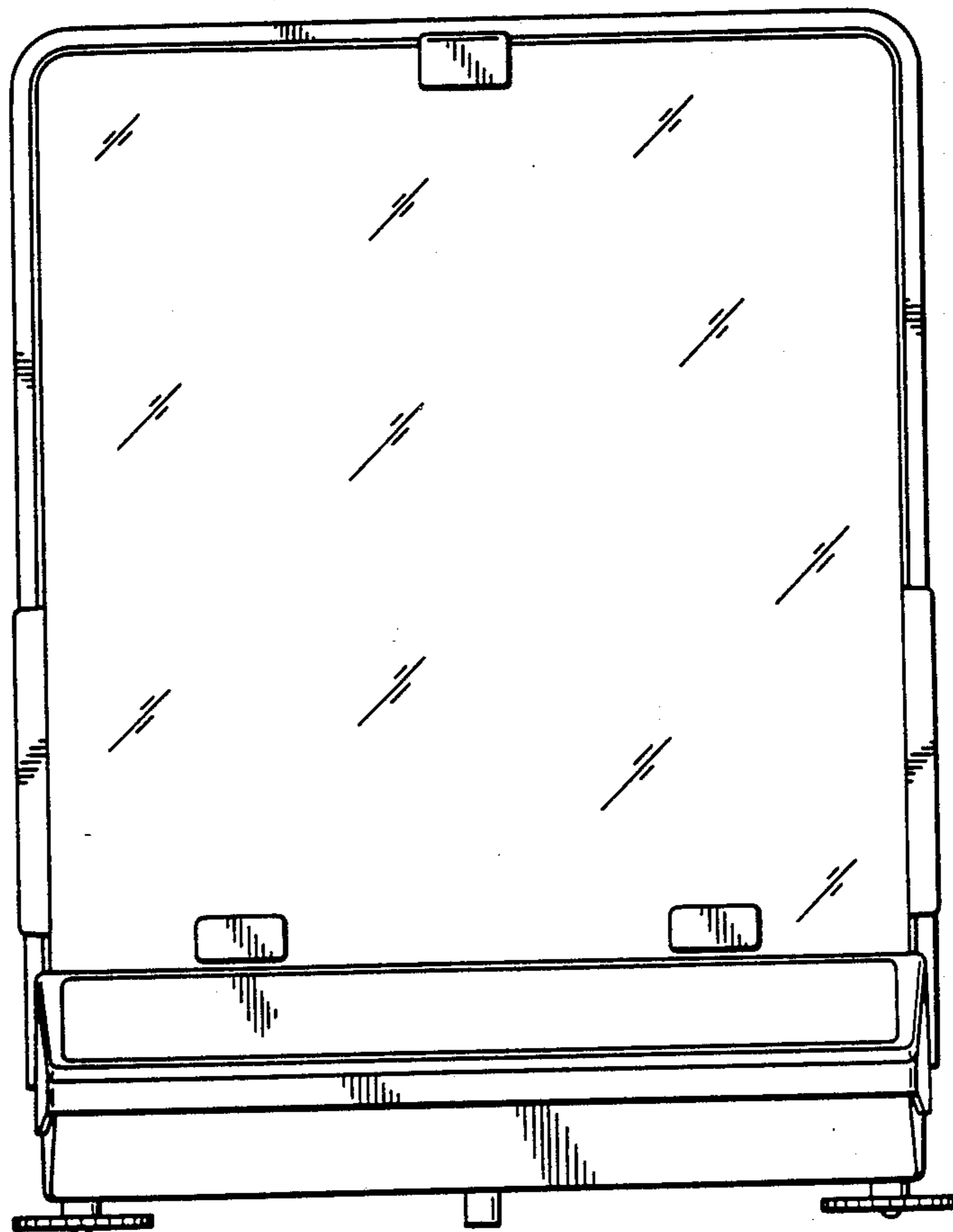

Fig. 28

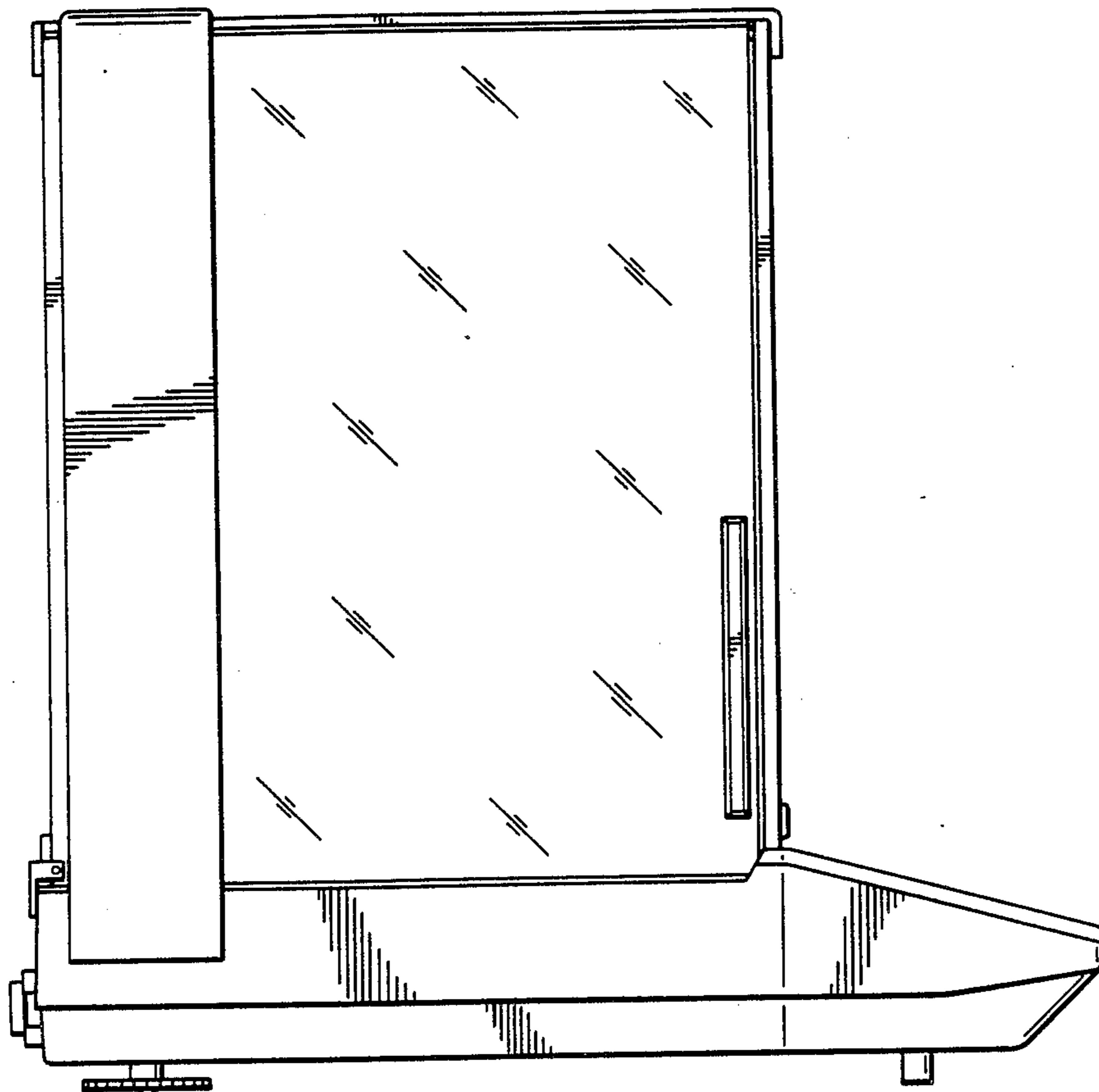

Fig. 29

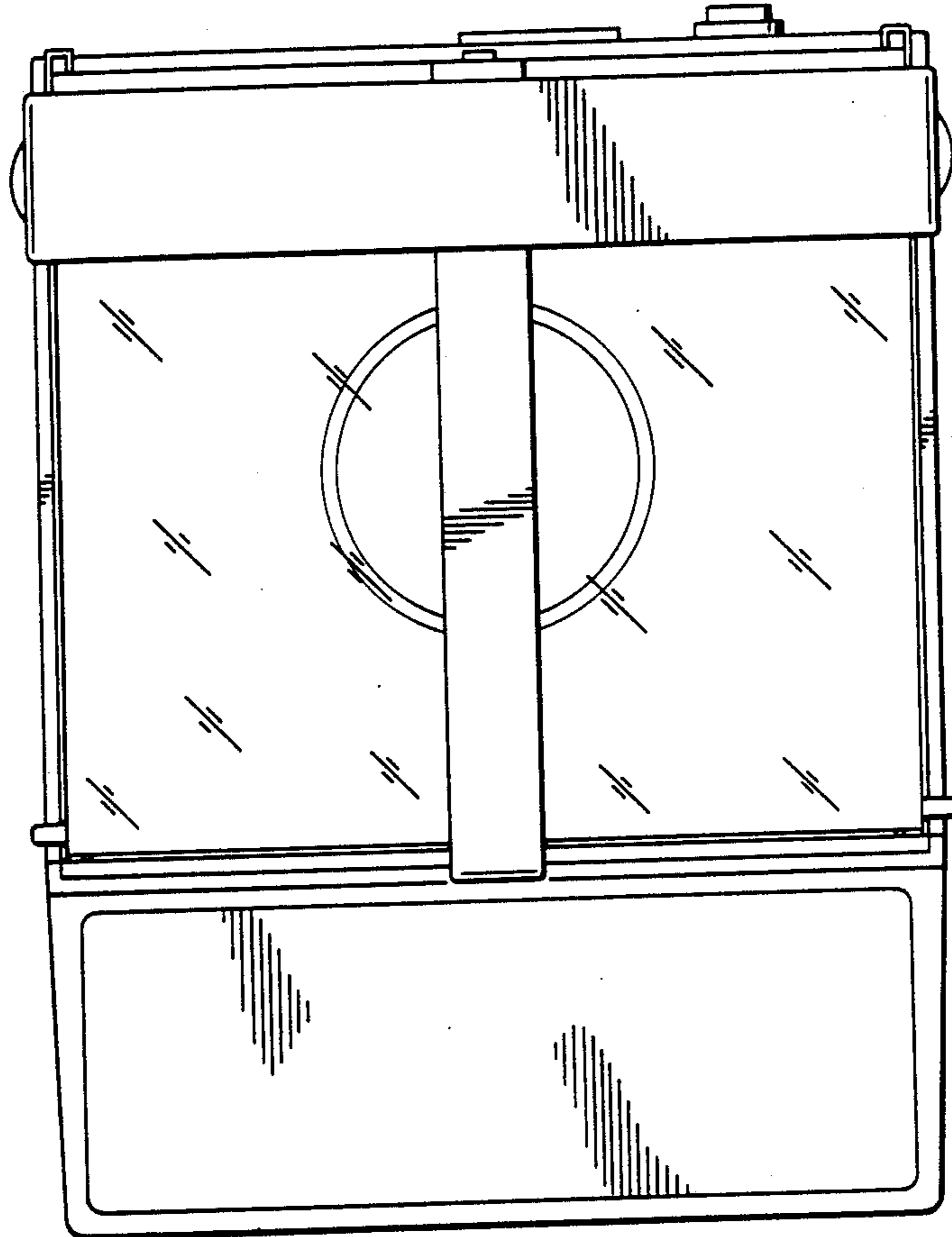

Fig. 30

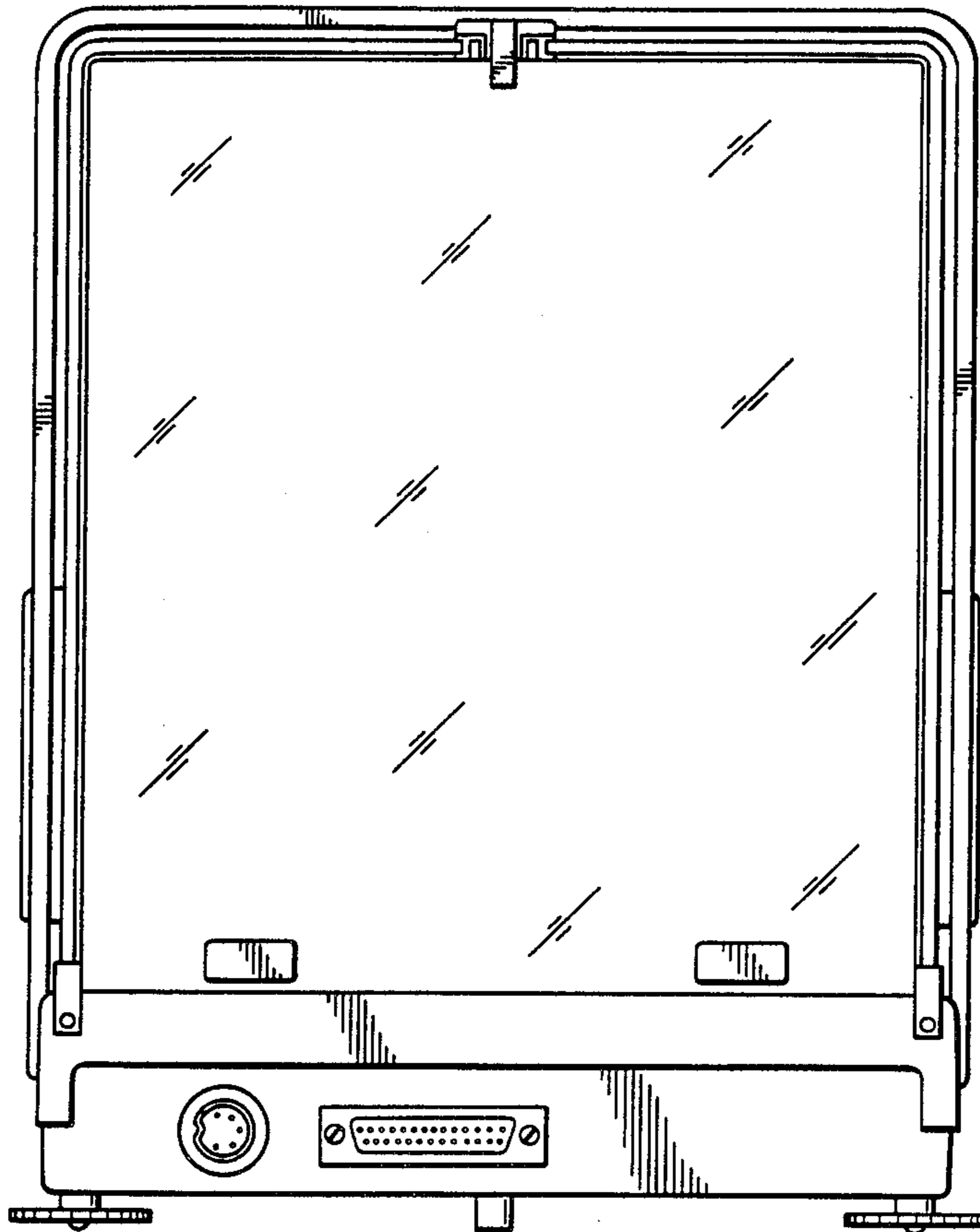

Fig. 31

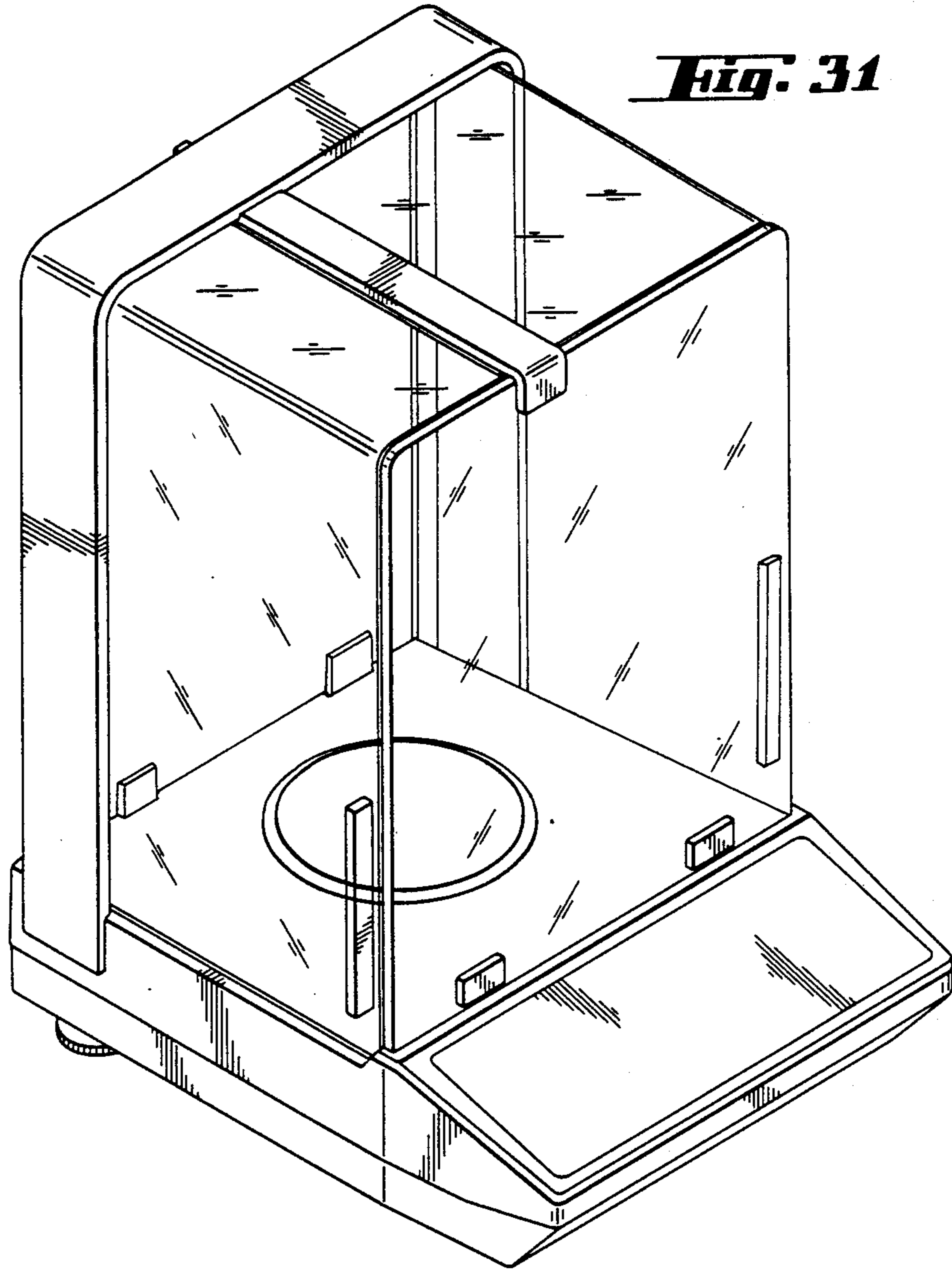

Fig. 32

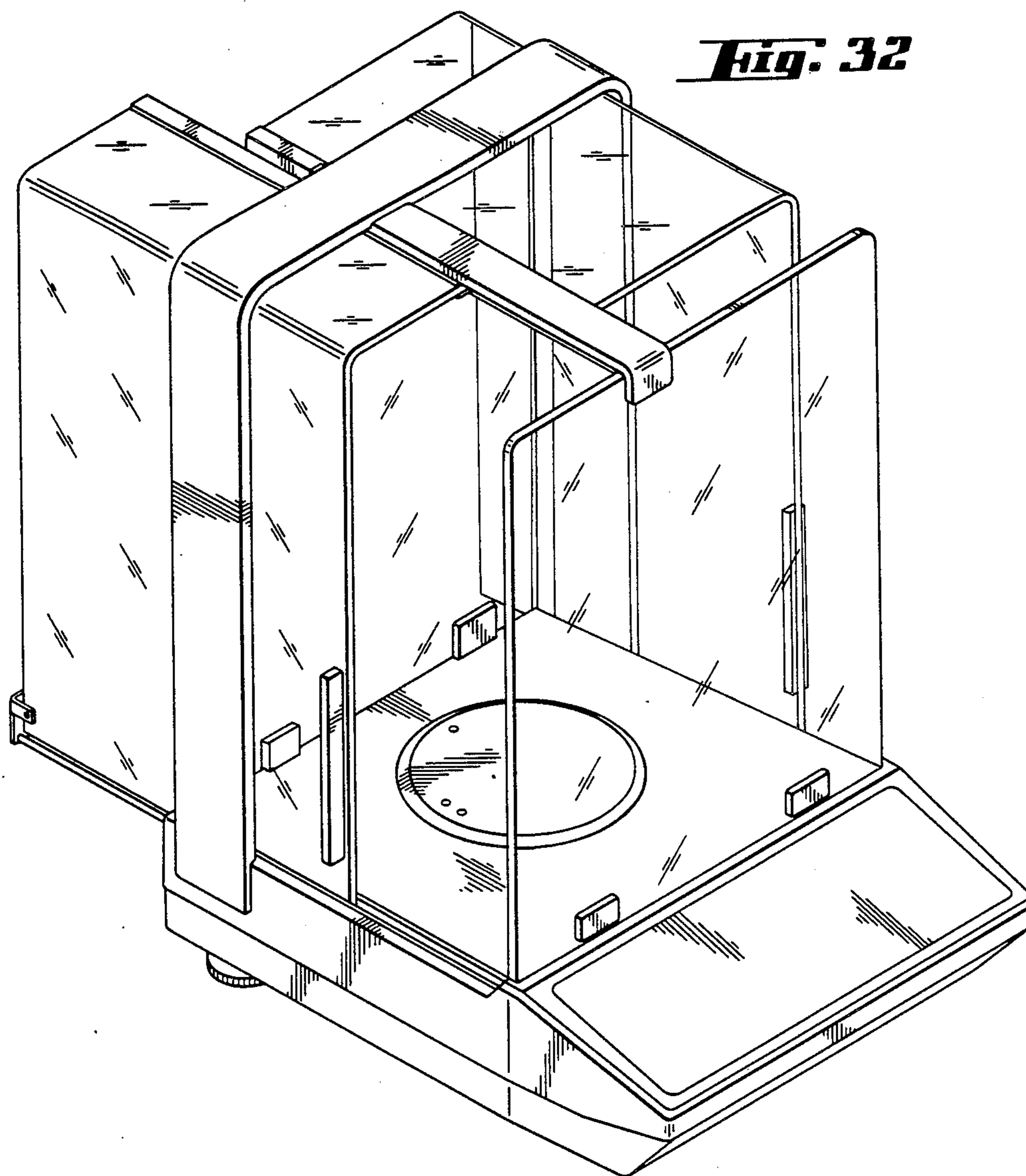

Fig. 33

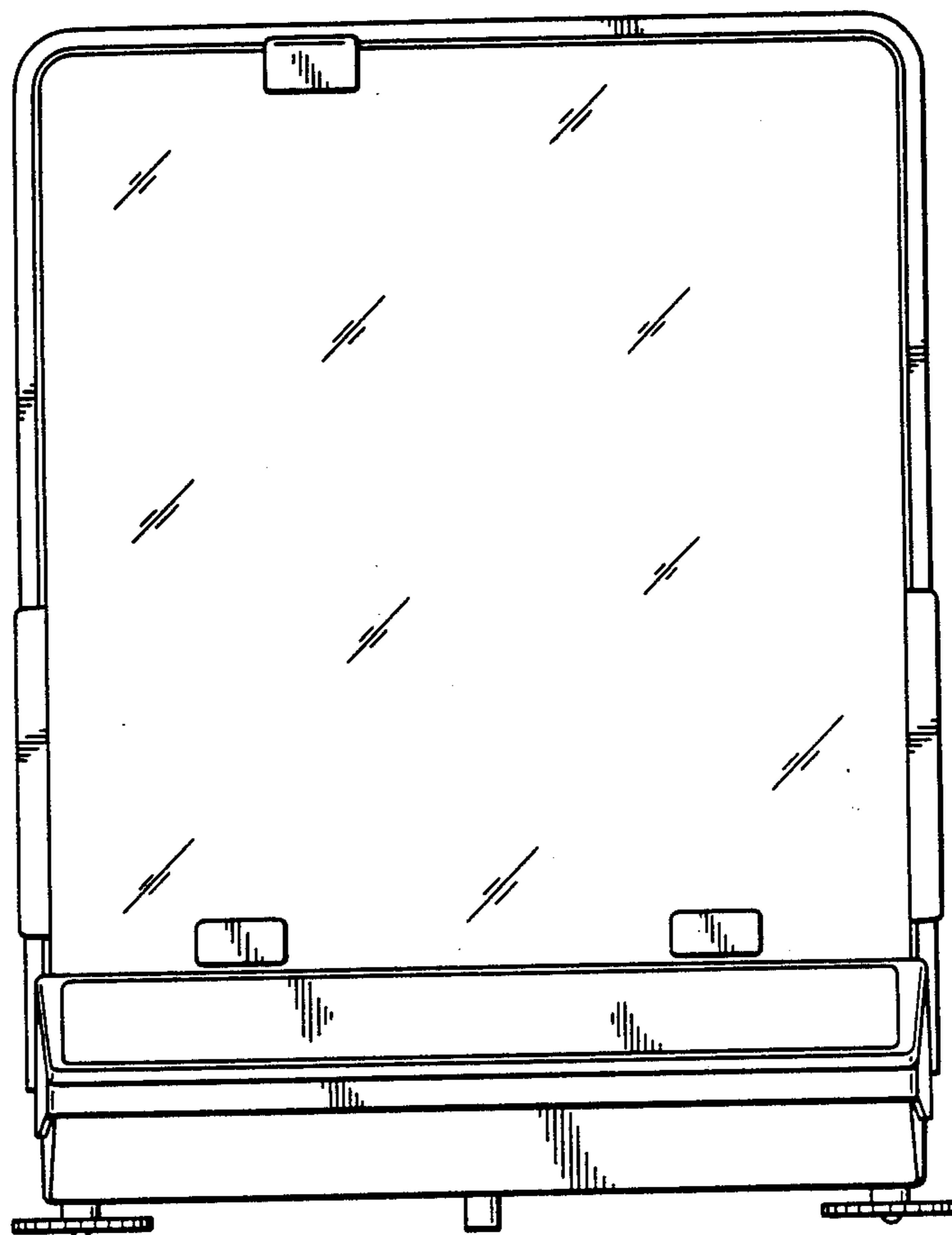

Fig. 34

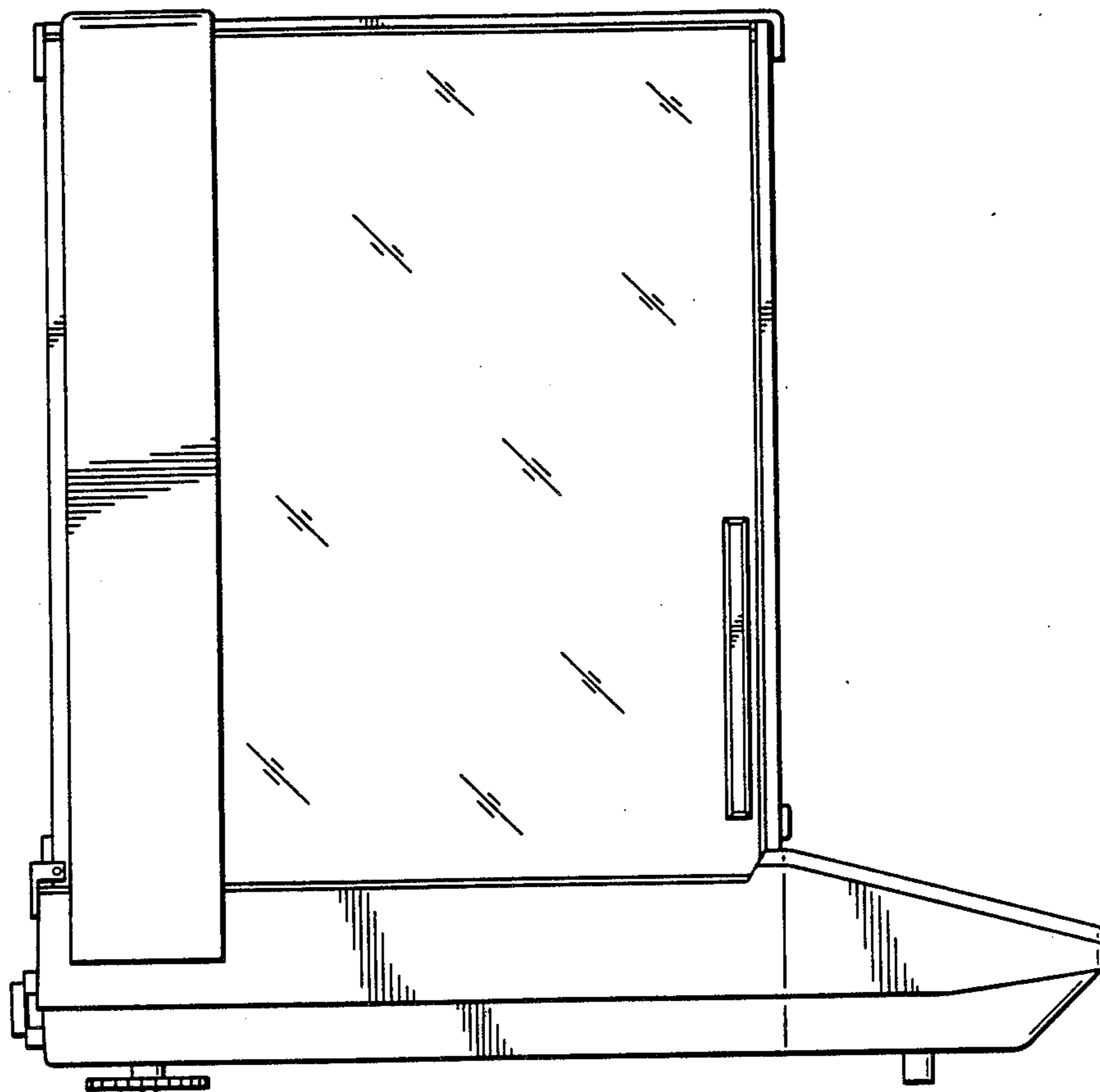

Fig. 35

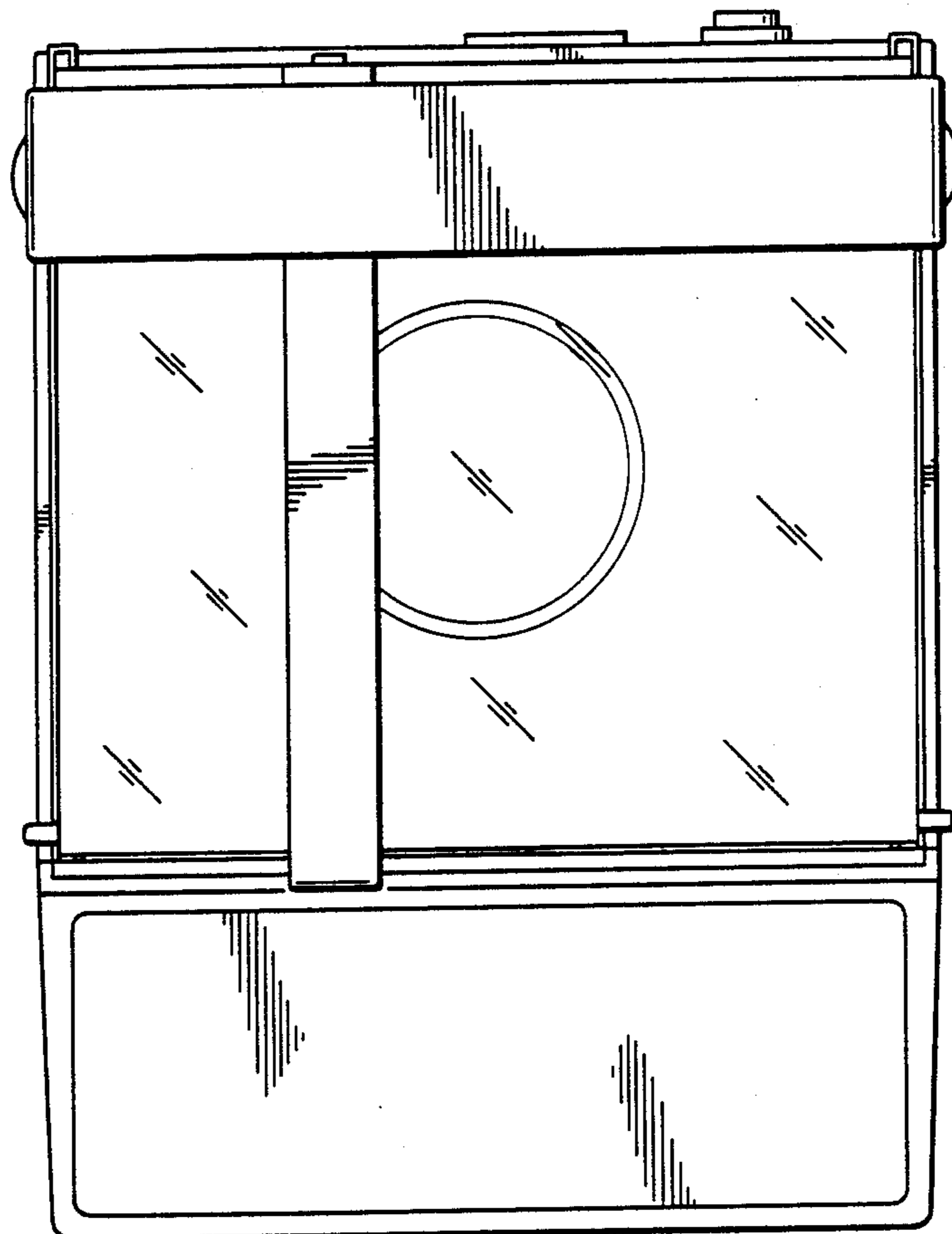

Fig. 36

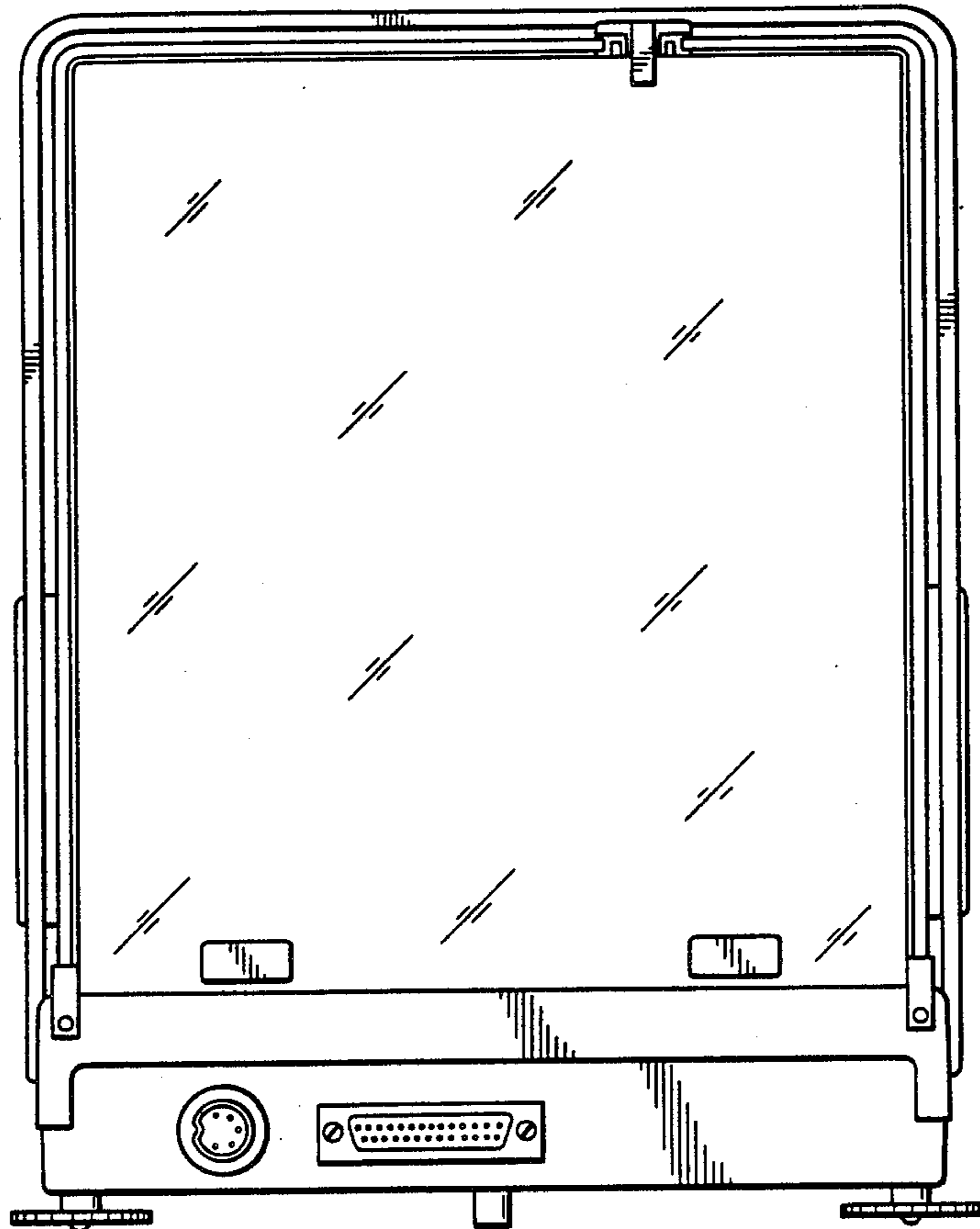

Fig. 37

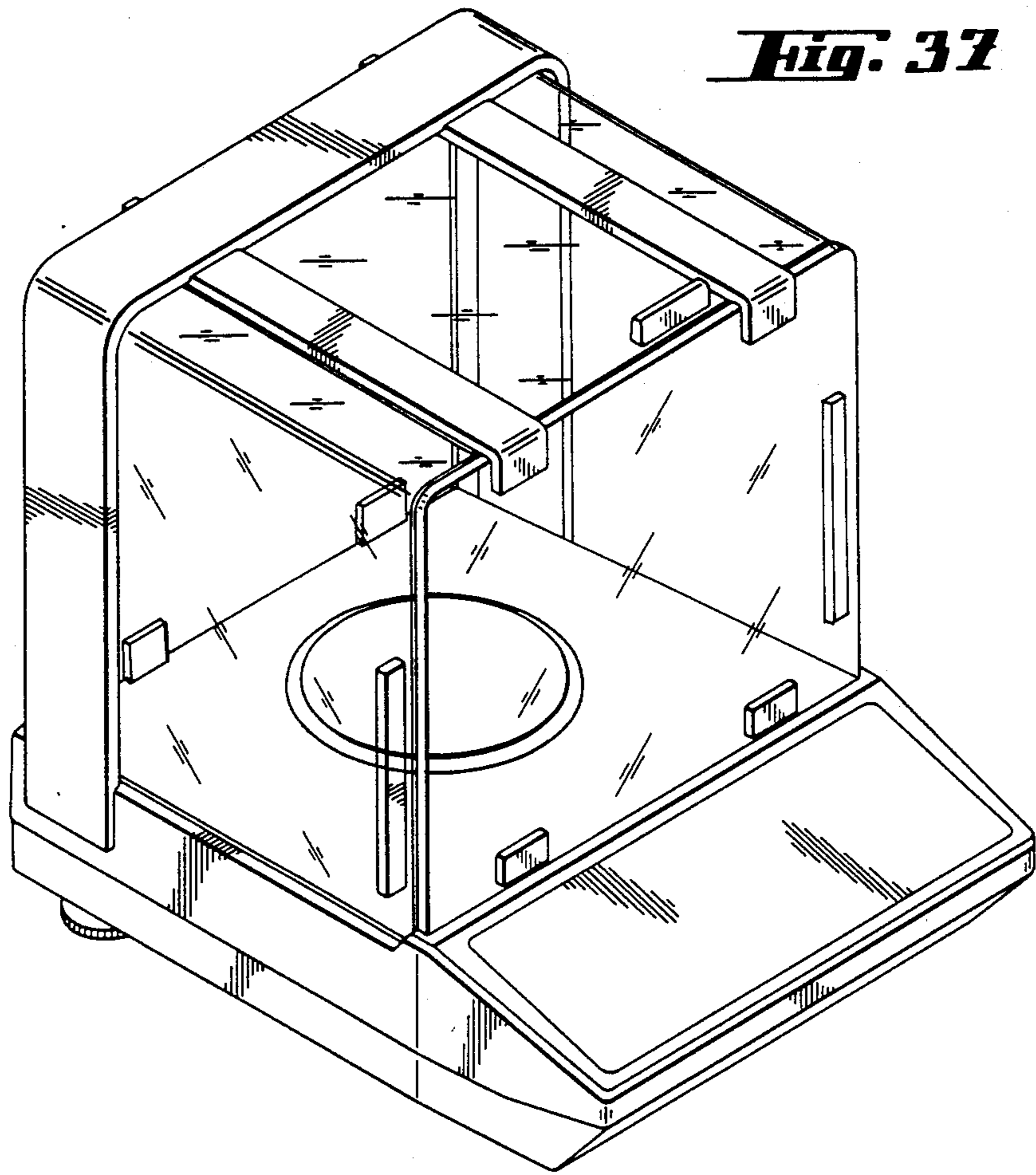

Fig. 38

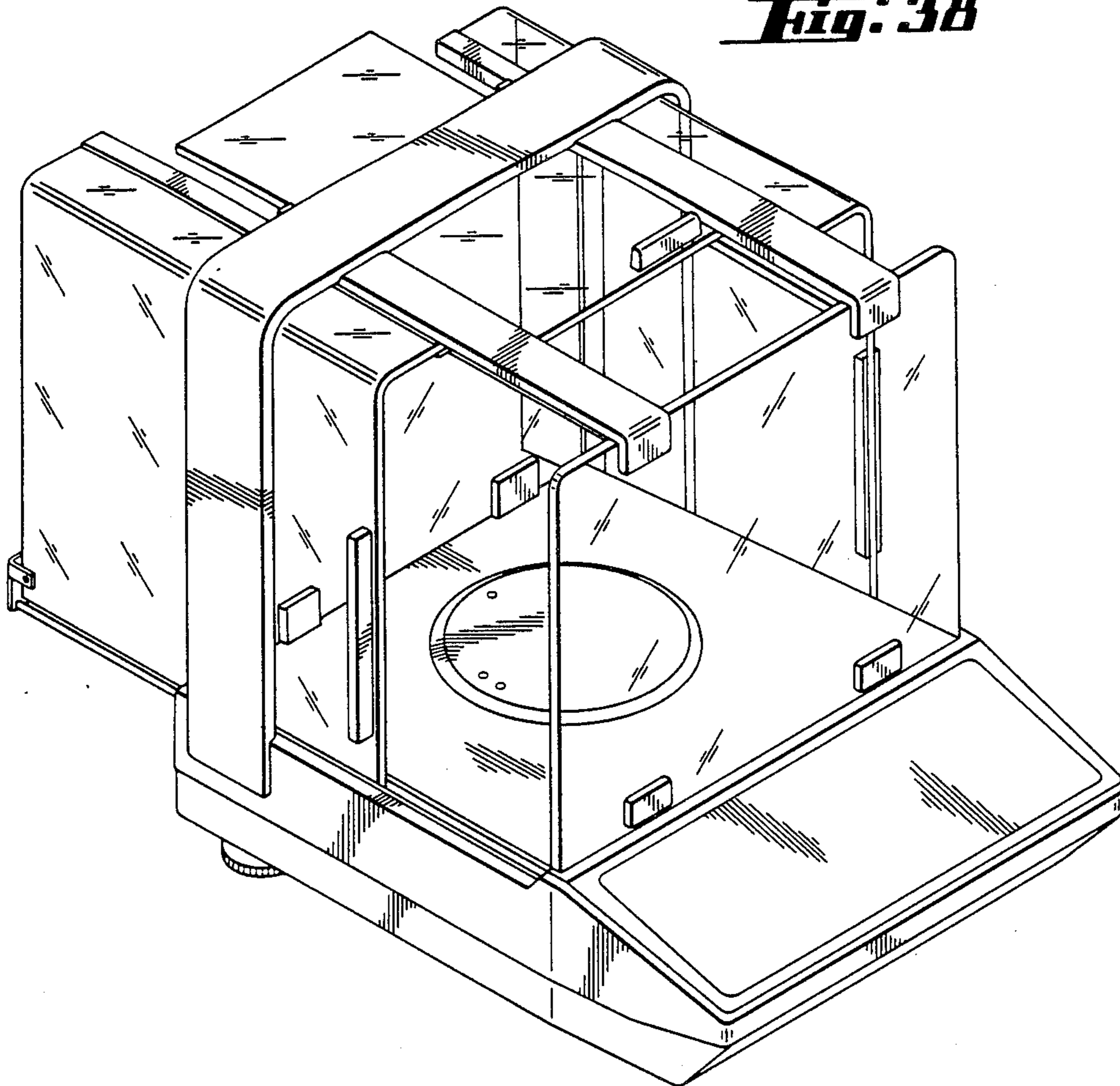

Fig. 39

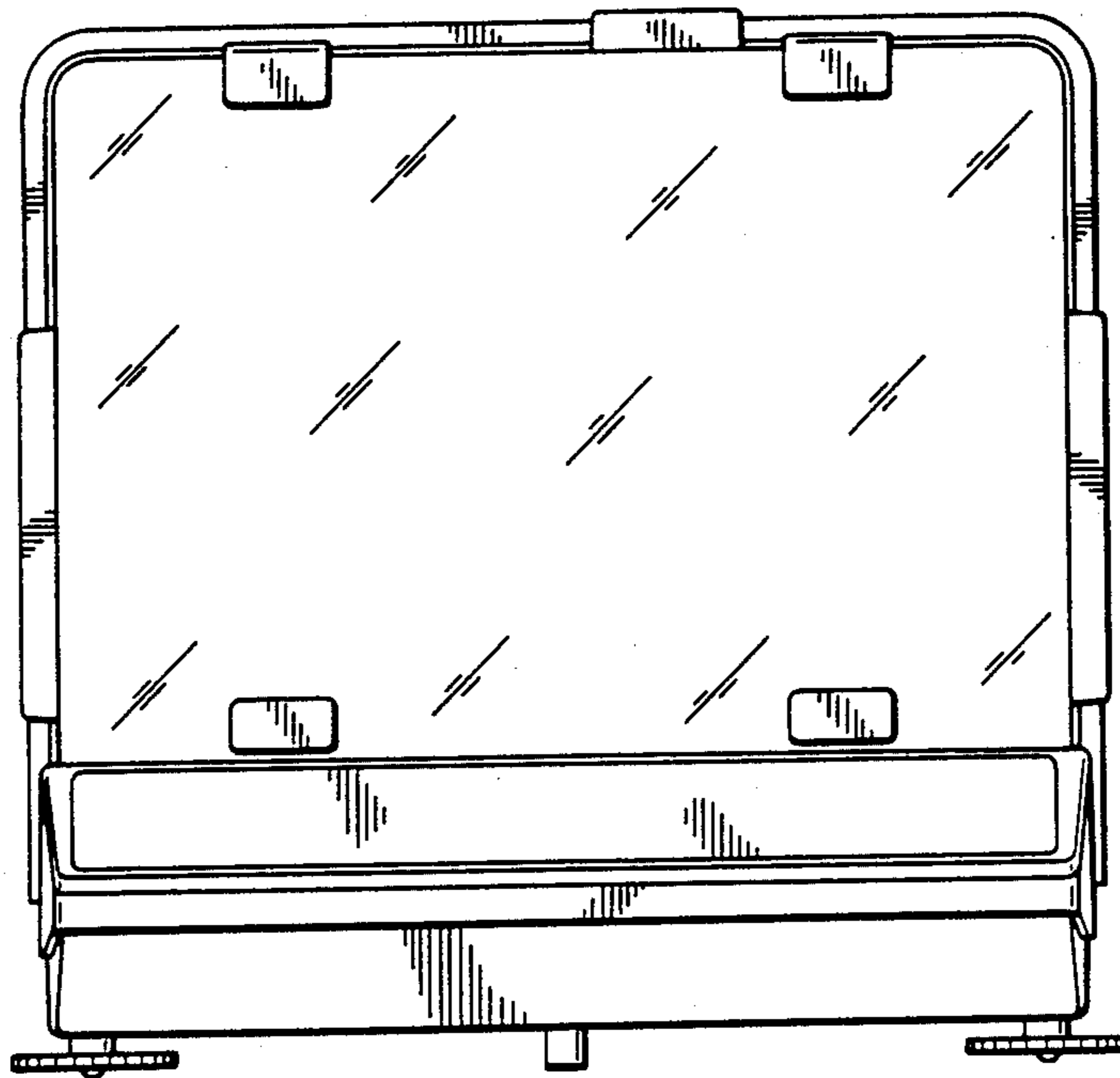

Fig. 40

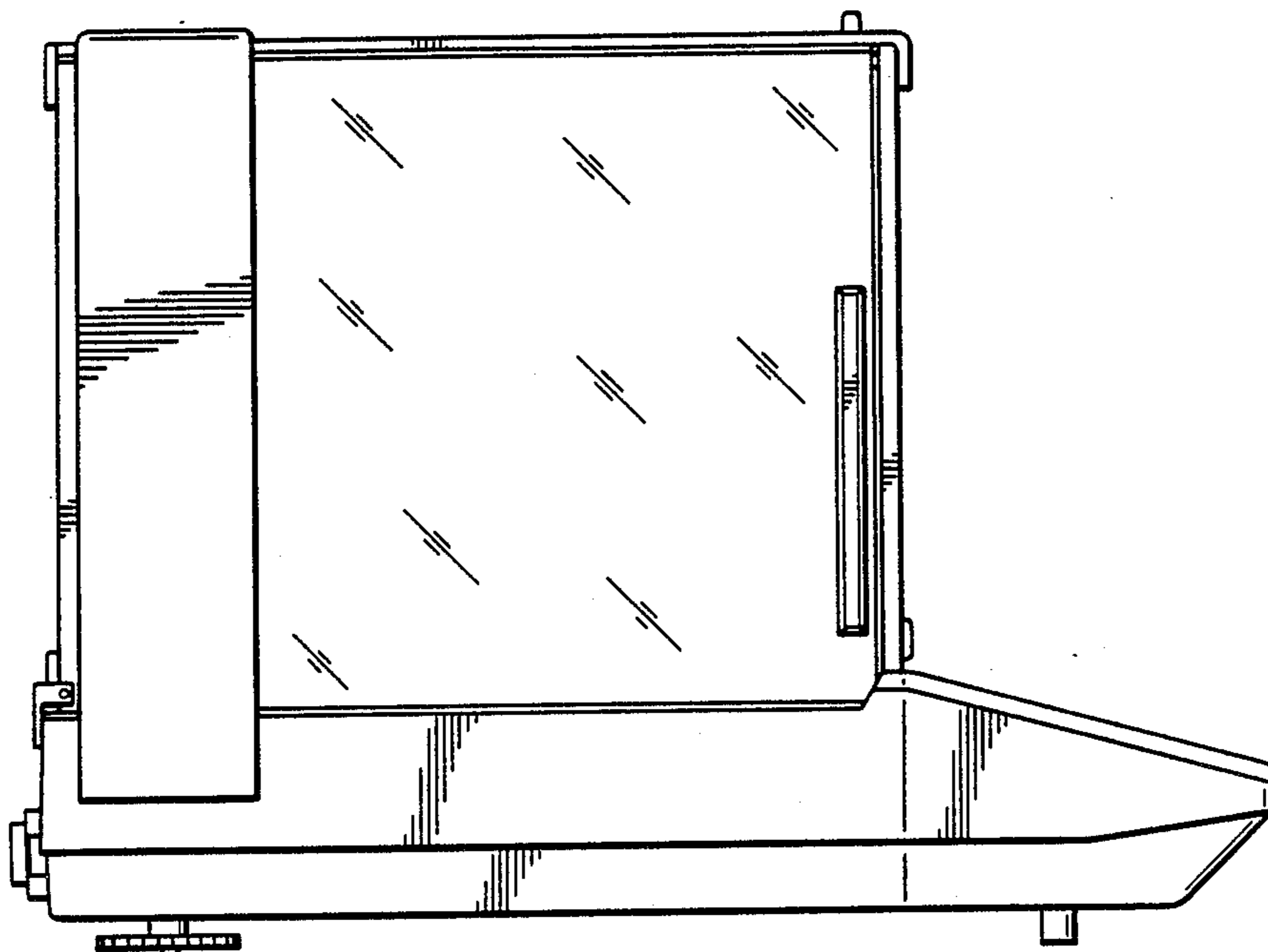

Fig. 4-1

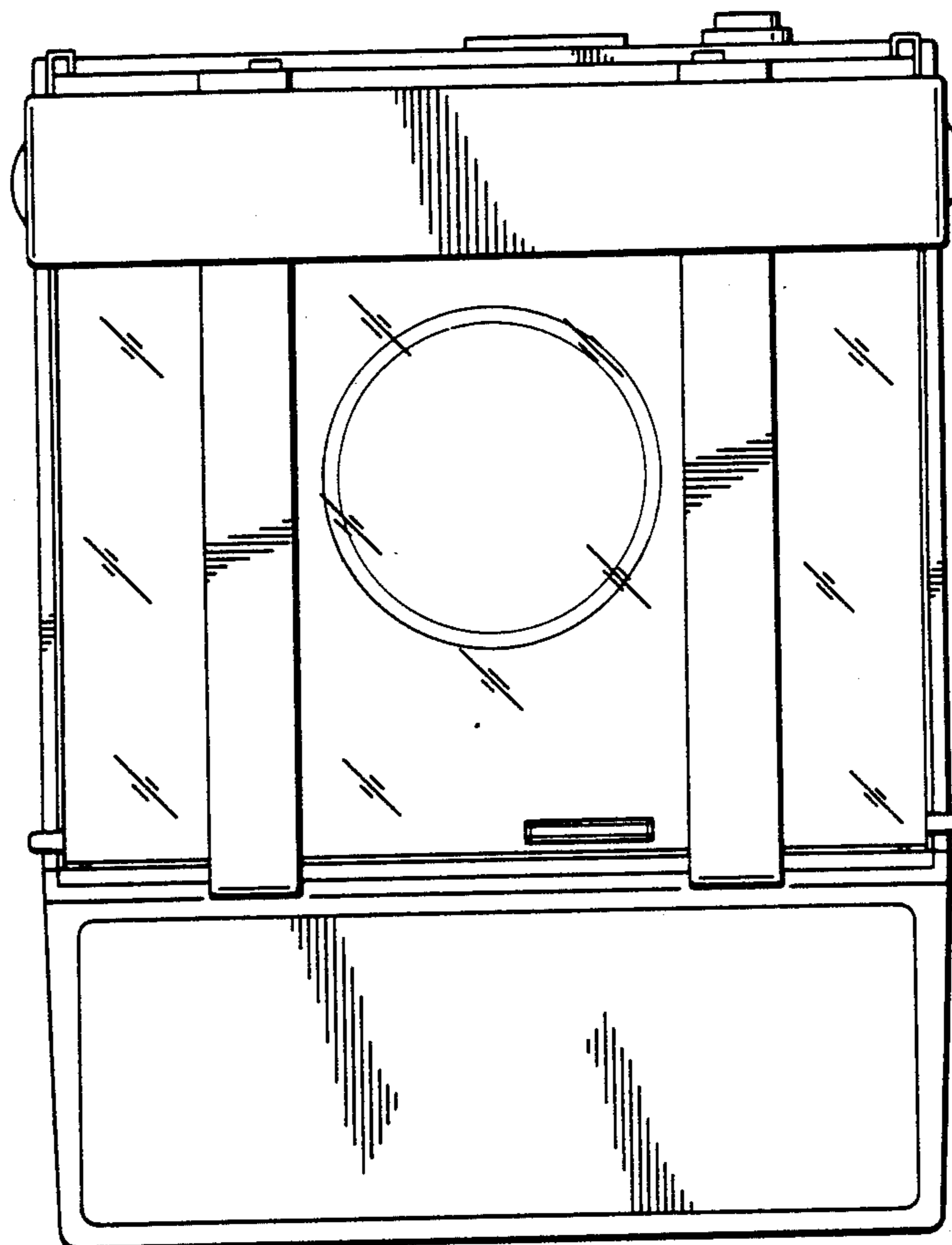

Fig. 42

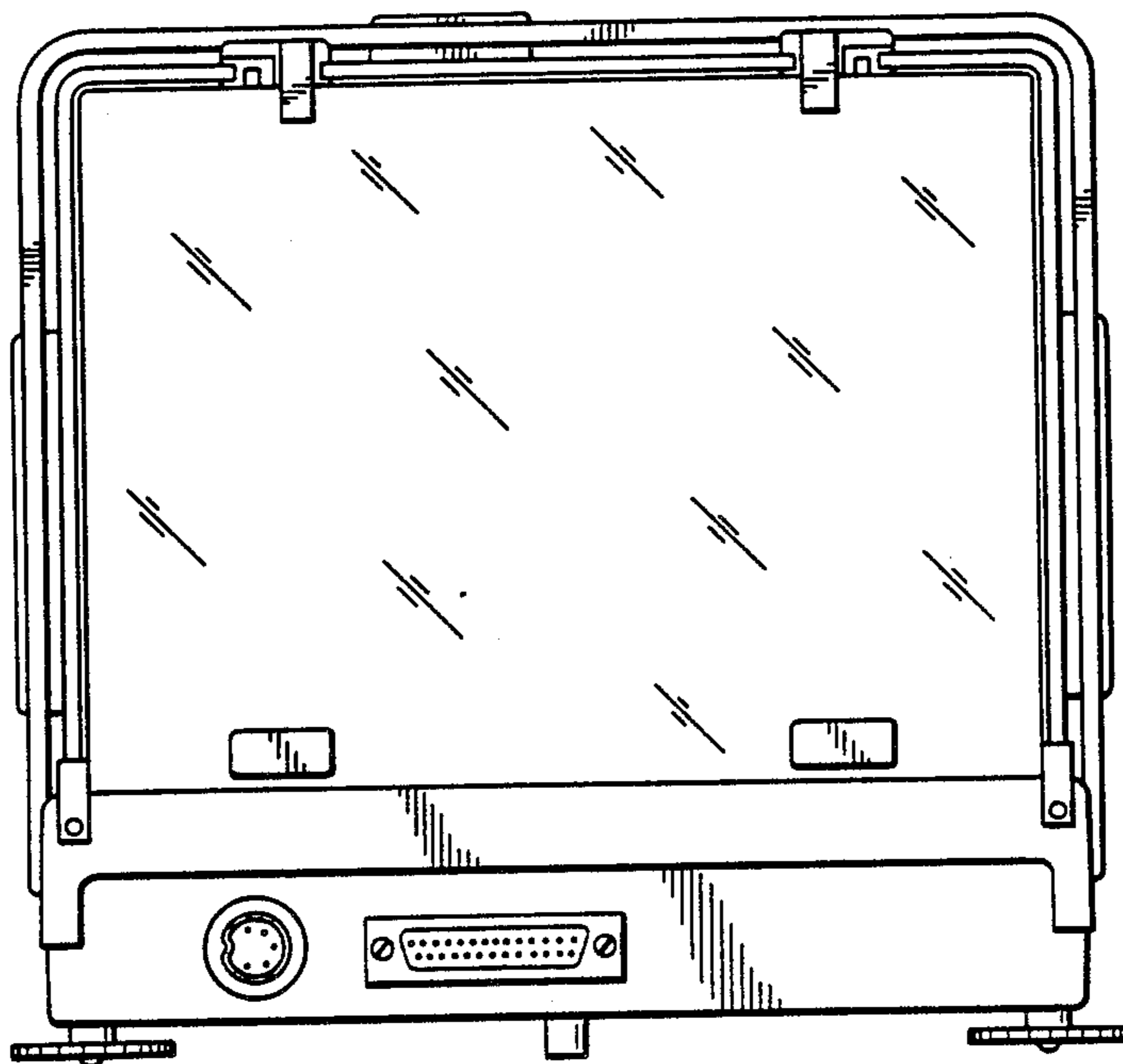
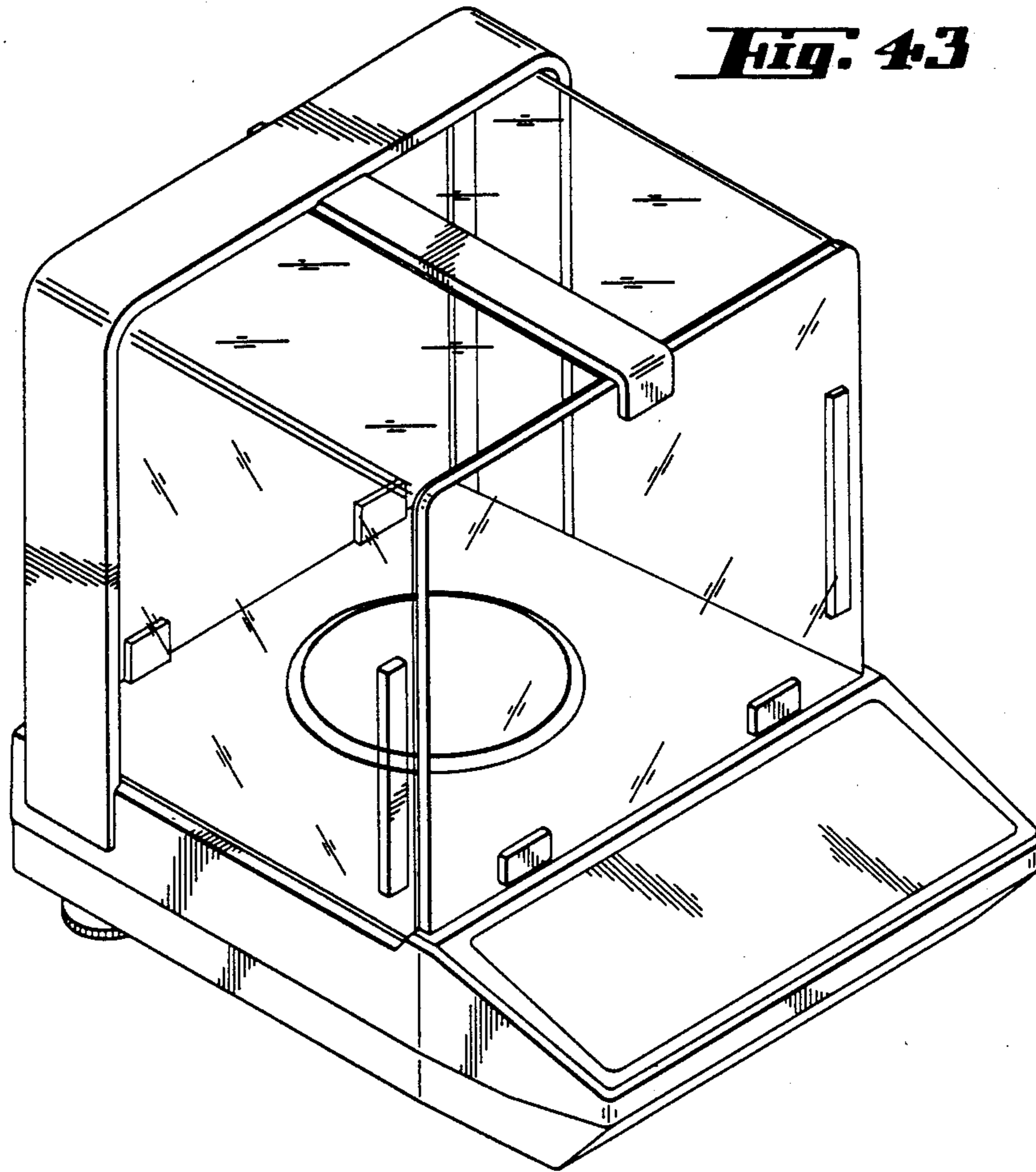

Fig. 4.3



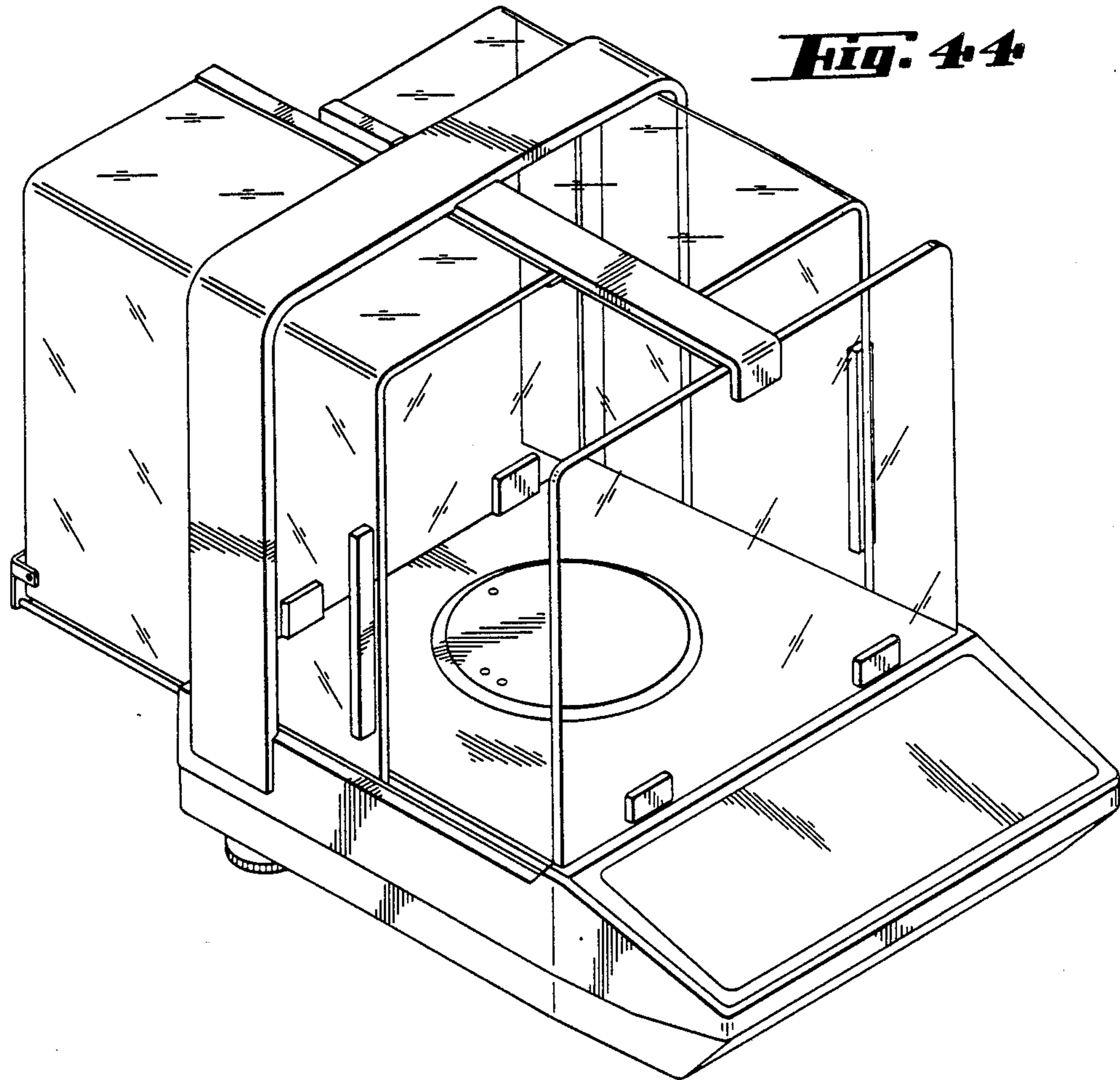

Fig. 44

Fig. 45

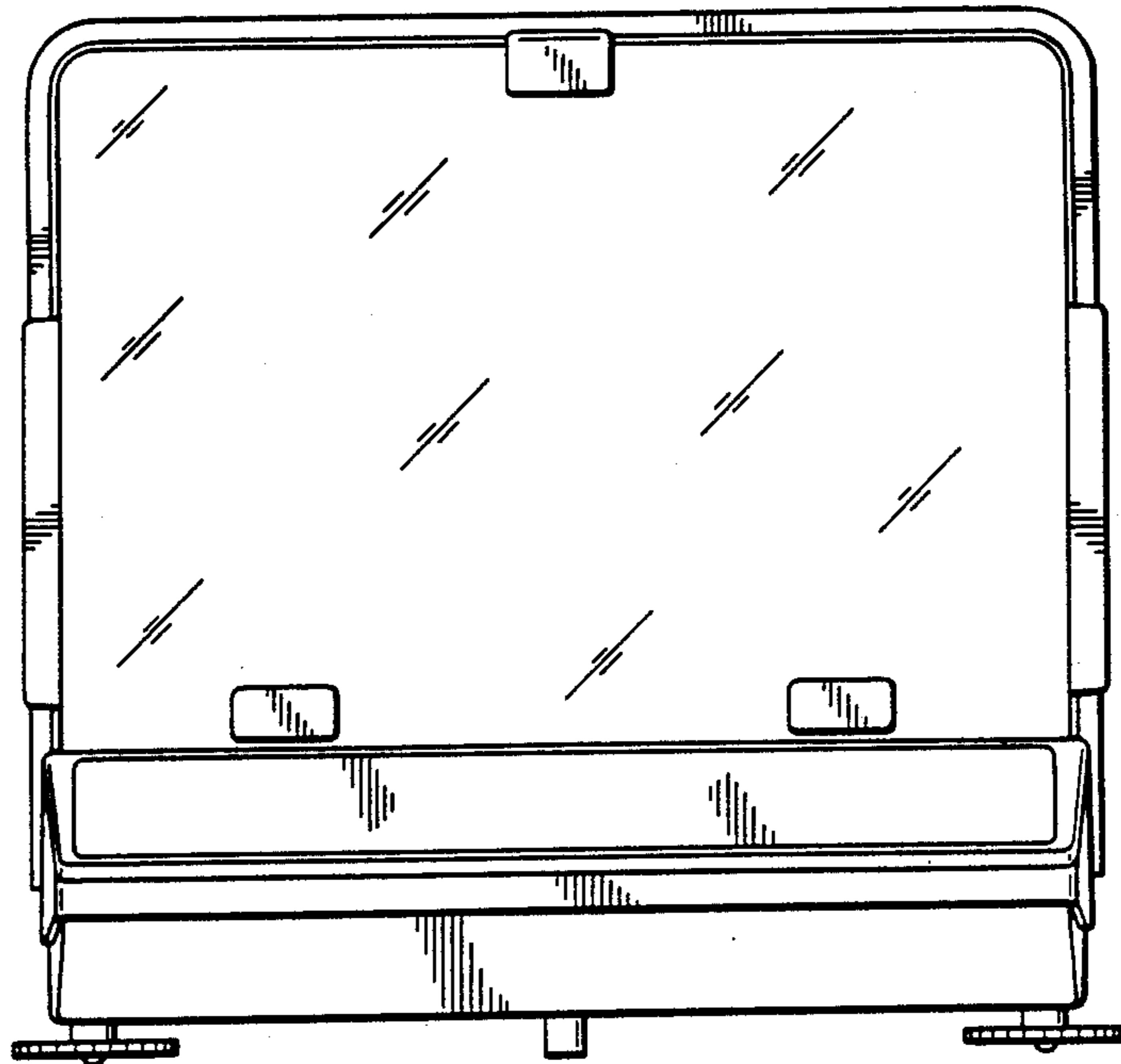

Fig. 4.6

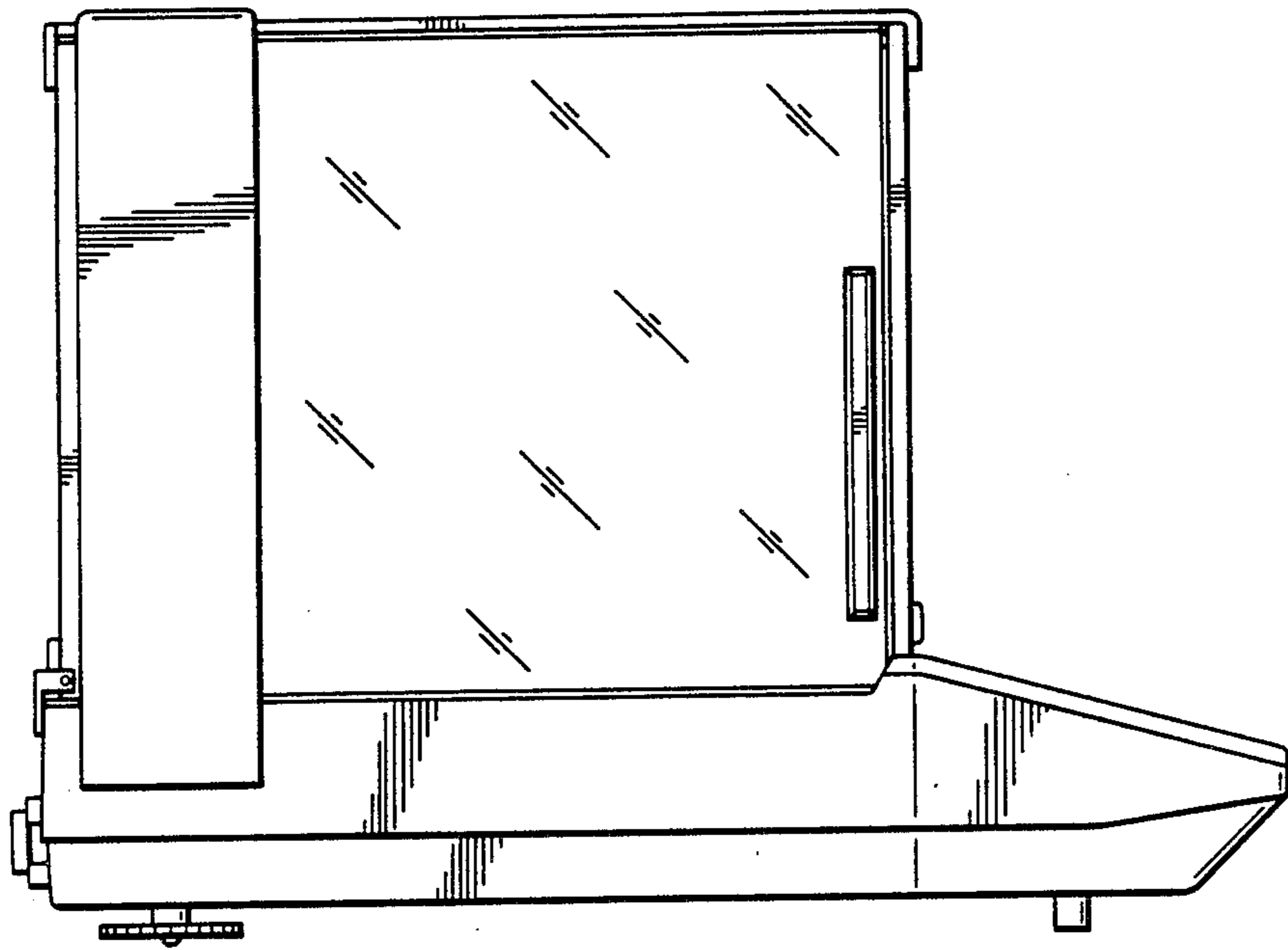

Fig. 47

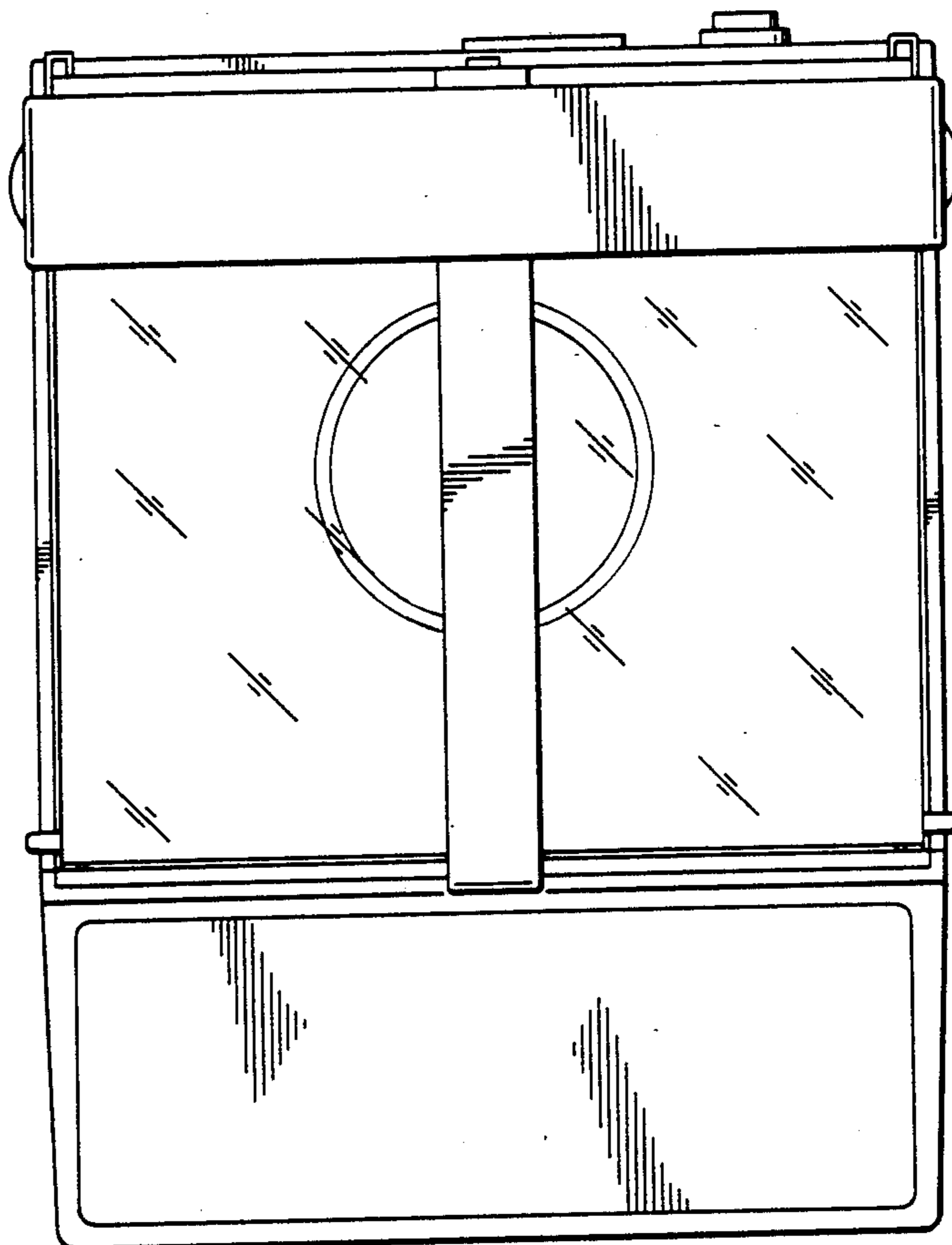
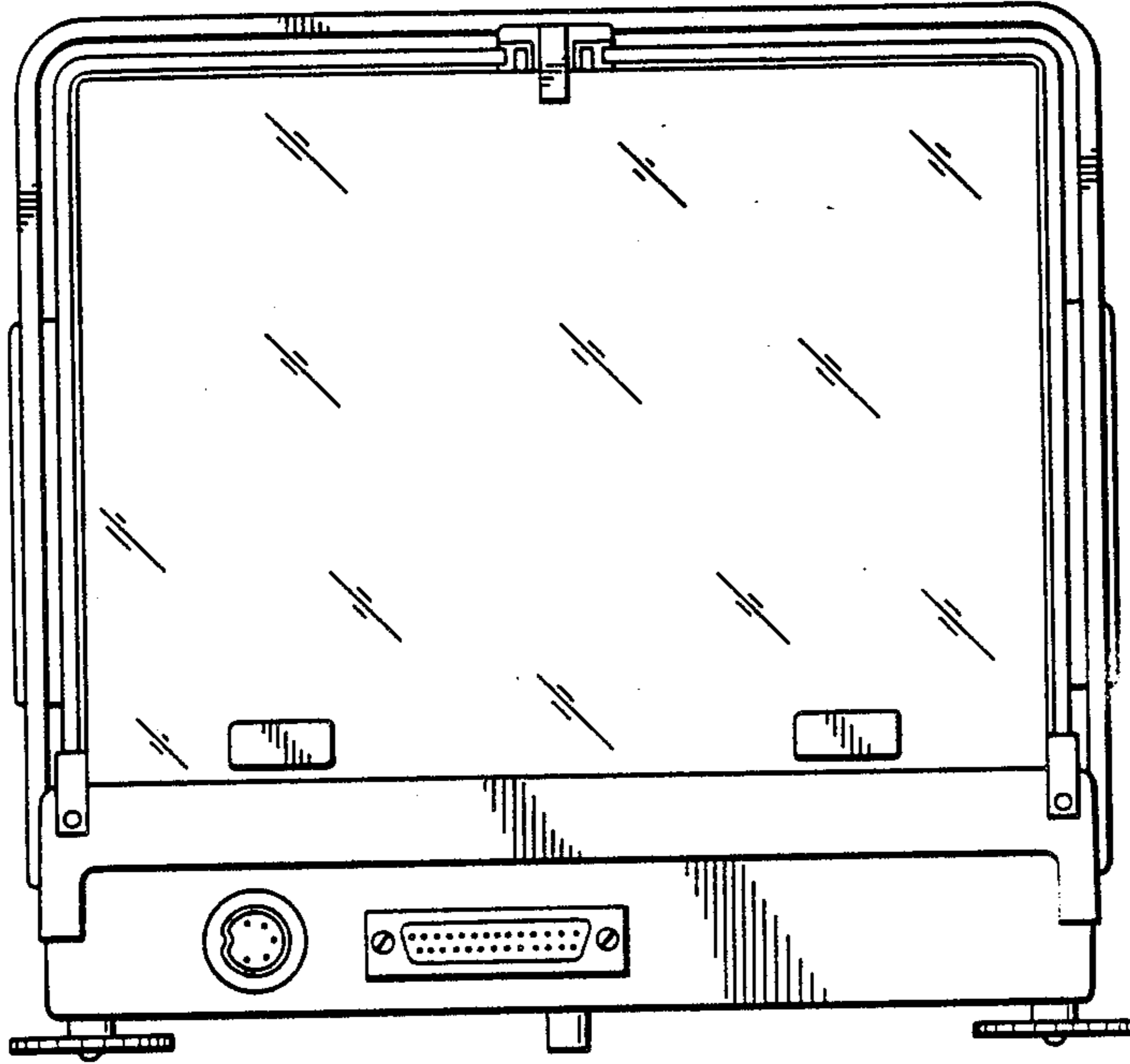

Fig. 4B



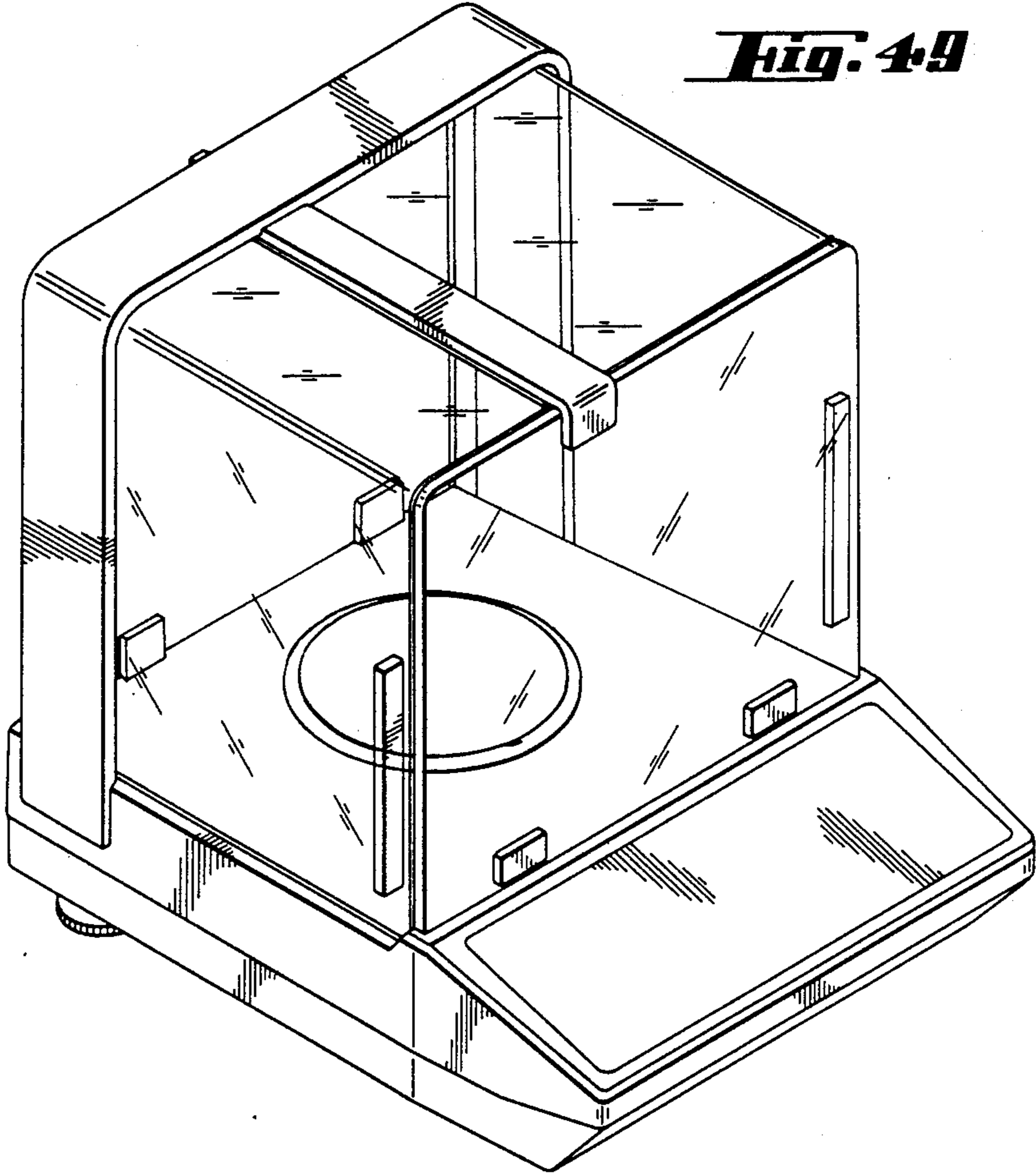

Fig. 50

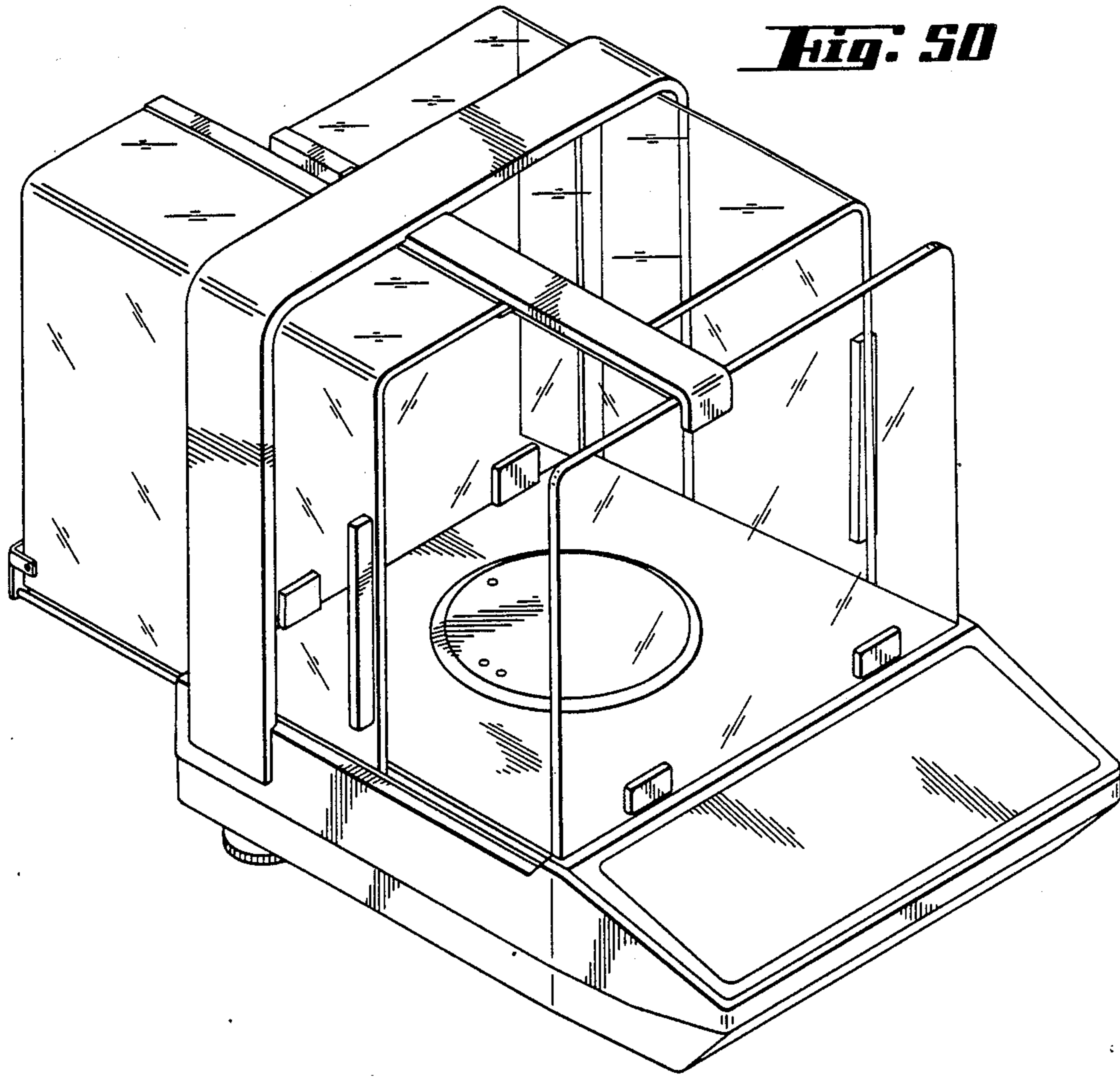

Fig. 51

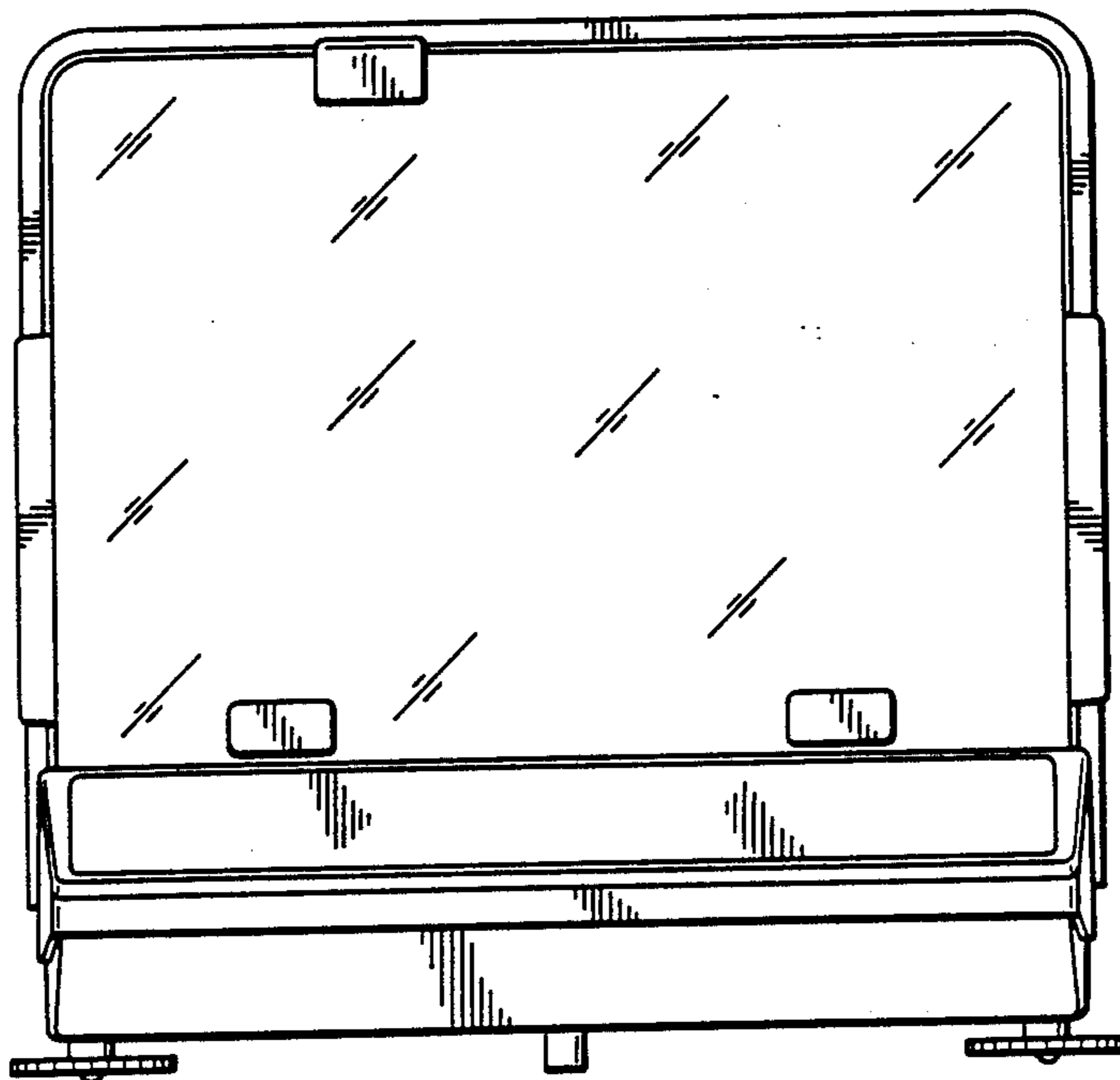

Fig. 52

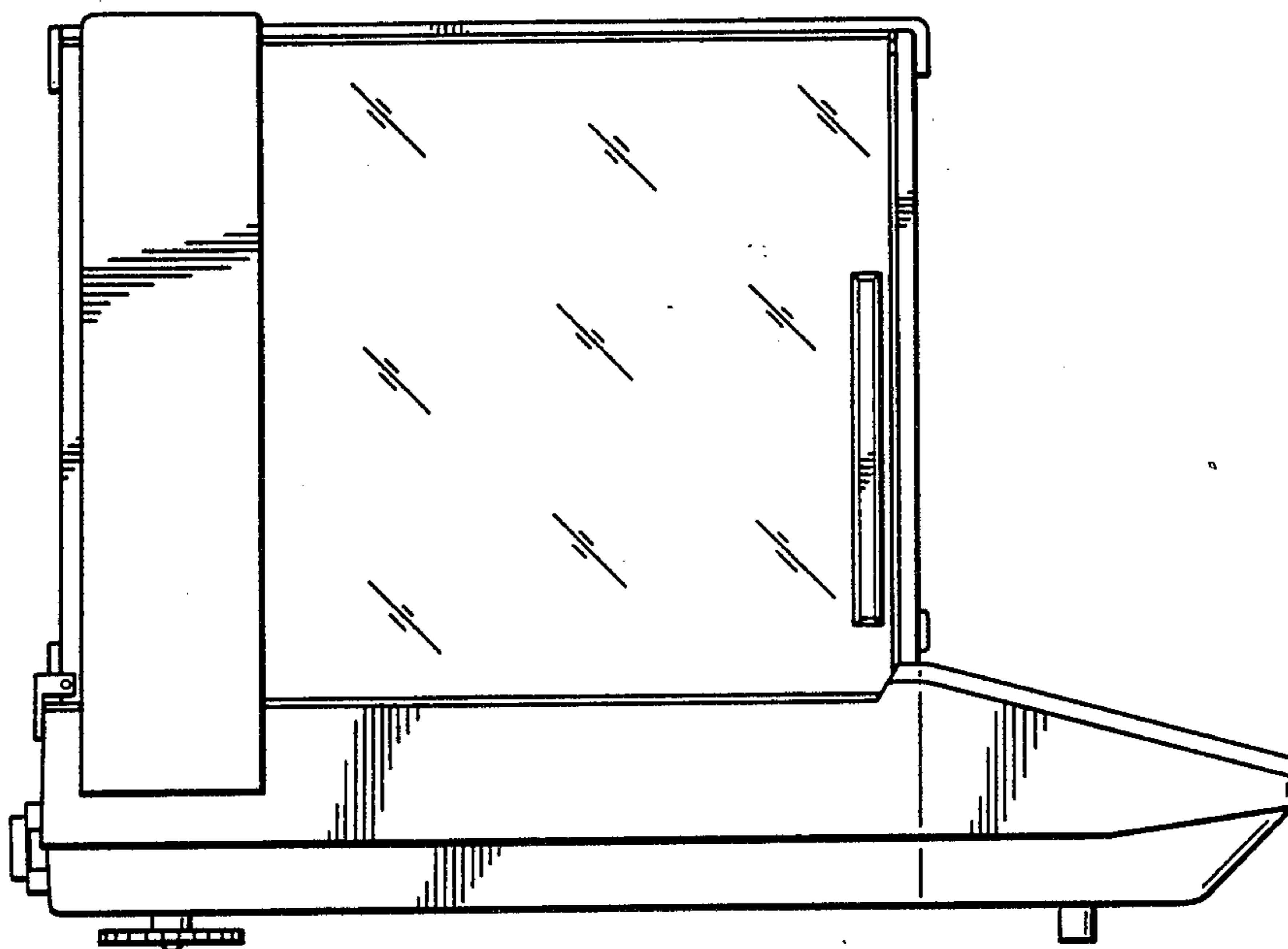

Fig. 53

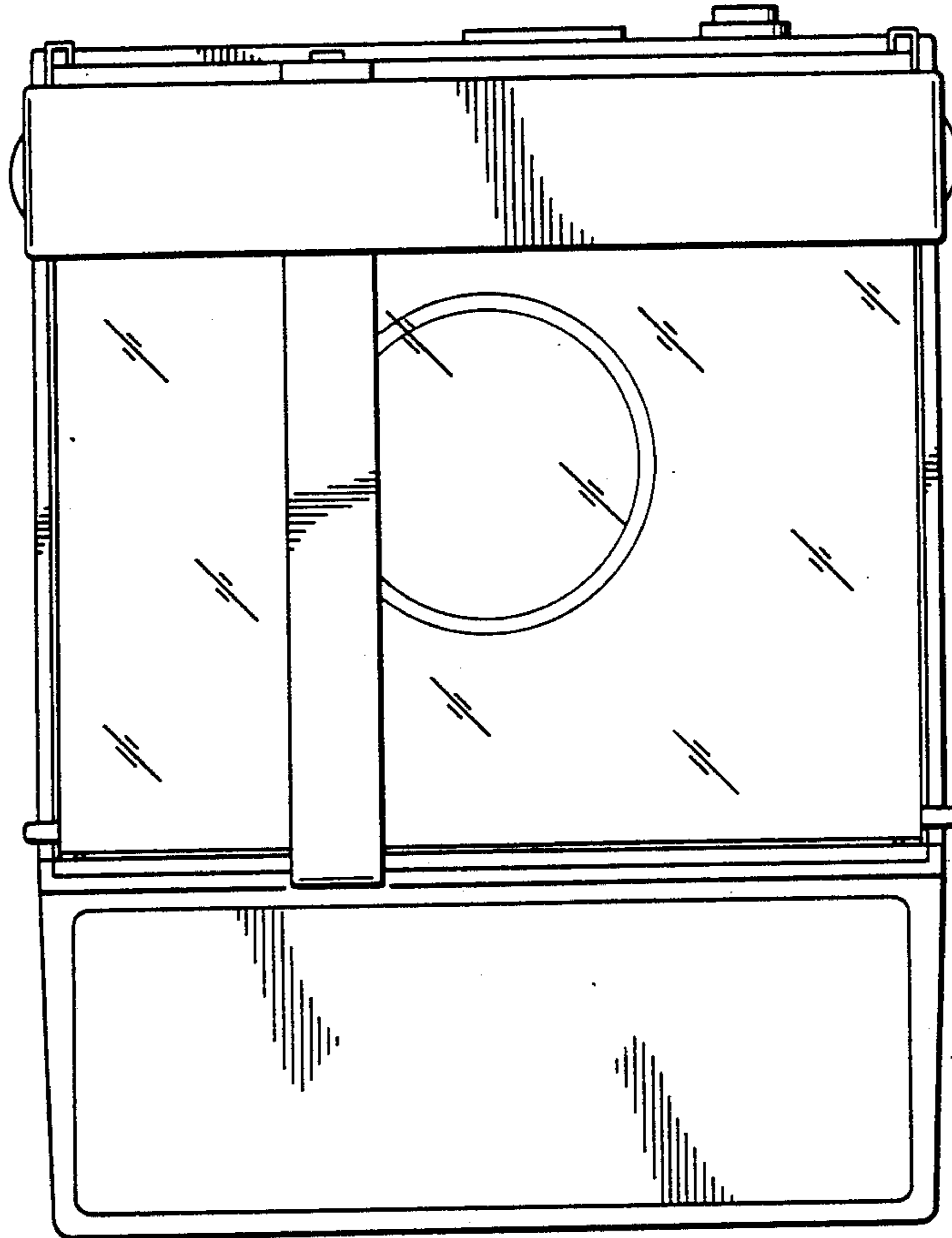

Fig. 54

