

[54] DOWNWARD PRESSURE MOP WRINGER

[75] Inventors: Philip Jaros, Gloversville; Paul O. Wright, Schenectady, both of N.Y.

[73] Assignee: White Mop Wringer Company, Fultonville, N.Y.

[\*\*] Term: 14 Years

[21] Appl. No.: 744,484

[22] Filed: Jun. 13, 1985

[52] U.S. Cl. .... D32/54

[58] Field of Search ..... D32/53, 53.1, 54; 15/260, 261, 262, 263

[56] References Cited

U.S. PATENT DOCUMENTS

D. 250,507	12/1978	Raftery et al. ....	D32/54
D. 255,976	7/1980	Maza et al. ....	D32/54
877,149	1/1908	Wetmore .	
1,659,505	2/1928	Welch et al. .	
1,831,135	11/1931	Pehrsson .	
1,871,903	8/1932	Neldner .....	15/261
2,199,906	5/1940	Bard .....	15/261
2,337,319	12/1943	Elkington .....	15/261
2,802,233	8/1957	Eberly et al. ....	15/261
3,452,379	7/1969	Bard .....	15/1
4,047,261	9/1977	Rones .....	15/261

OTHER PUBLICATIONS

Rubbermaid Sanitary Maintenance catalog, 1980, pp. 1, 2, 15.

Baystate/Dover, "Downward Pressure Wringers".

Geerpres, "Downward Pressure Wringers", 1983.

Continental, "Continental's Full Line of Structolene Mop Wringers".

White Mop Wringer Co. Product brochure, 1980, pp. 2-3, 6-10, 16-17, 24.

White Floor Cleaning Equipment and Maintenance Accessories, 1967, pp. 2-3, 6-9, 13-14.

Primary Examiner—Catherine E. Kemper

Attorney, Agent, or Firm—Douglas J. Gilbert; Robert R. Jackson

[57] CLAIM

The ornamental design for a downward pressure mop wringer, substantially as shown and described.

DESCRIPTION

FIG. 1 is a front perspective view of a downward pressure mop wringer, showing our new design;

FIG. 2 is a side elevational view as seen from the right of FIG. 1;

FIG. 3 is a front elevational view thereof;

FIG. 4 is a top plan view thereof;

FIG. 5 is a rear elevational view thereof; and

FIG. 6 is a bottom plan view thereof.

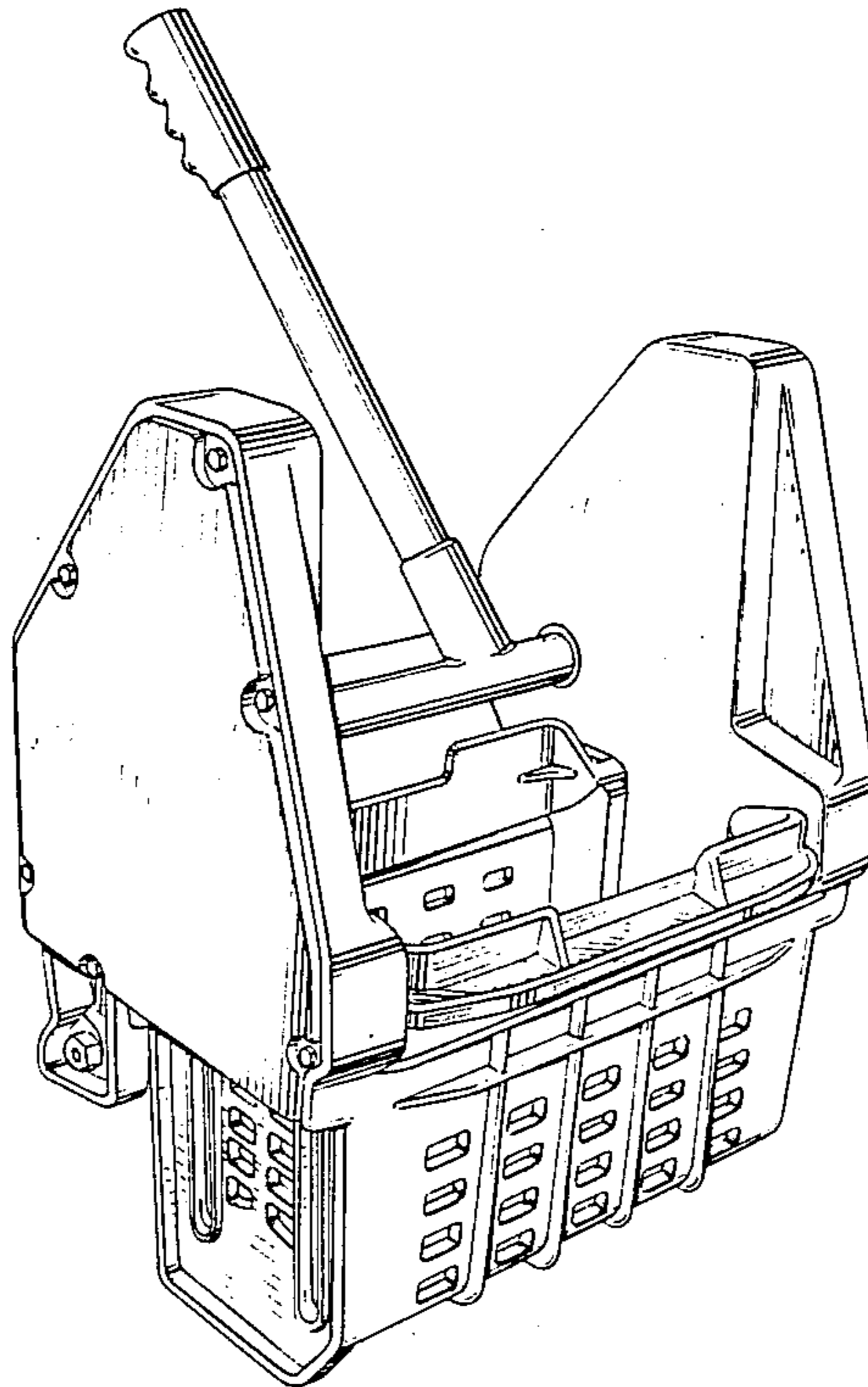

Fig. 1.

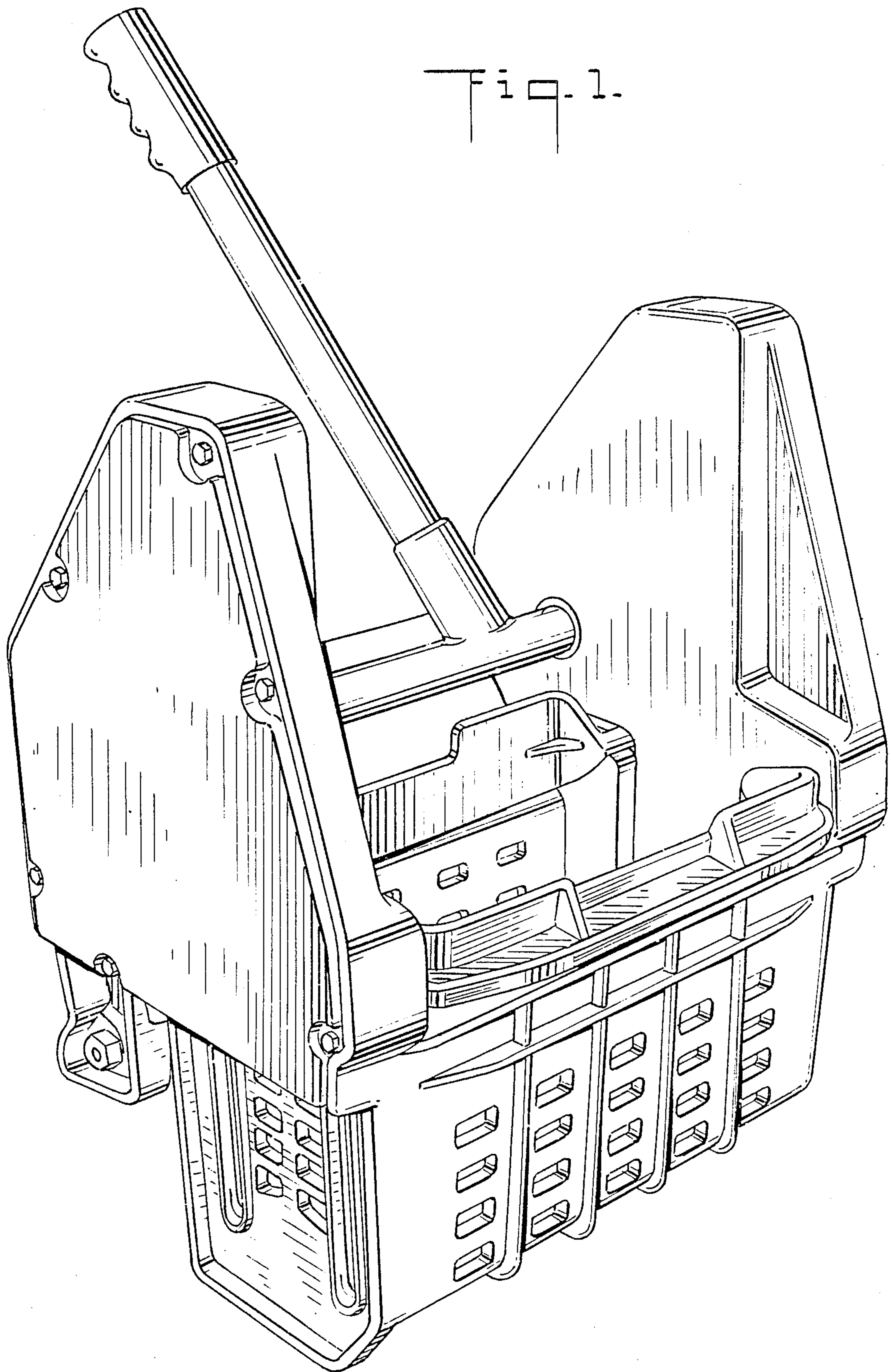

Fig. 2.

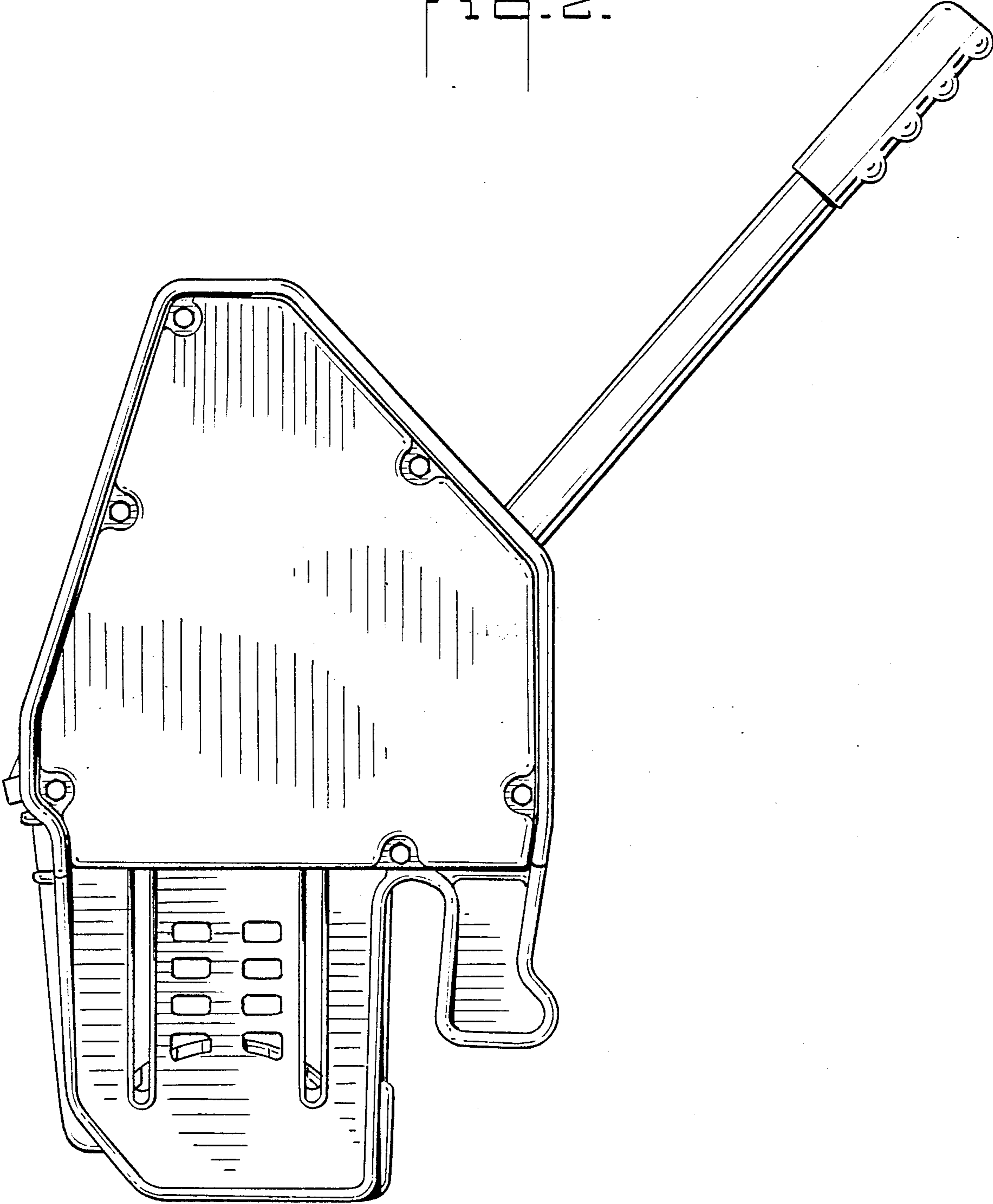

Fig. 3.

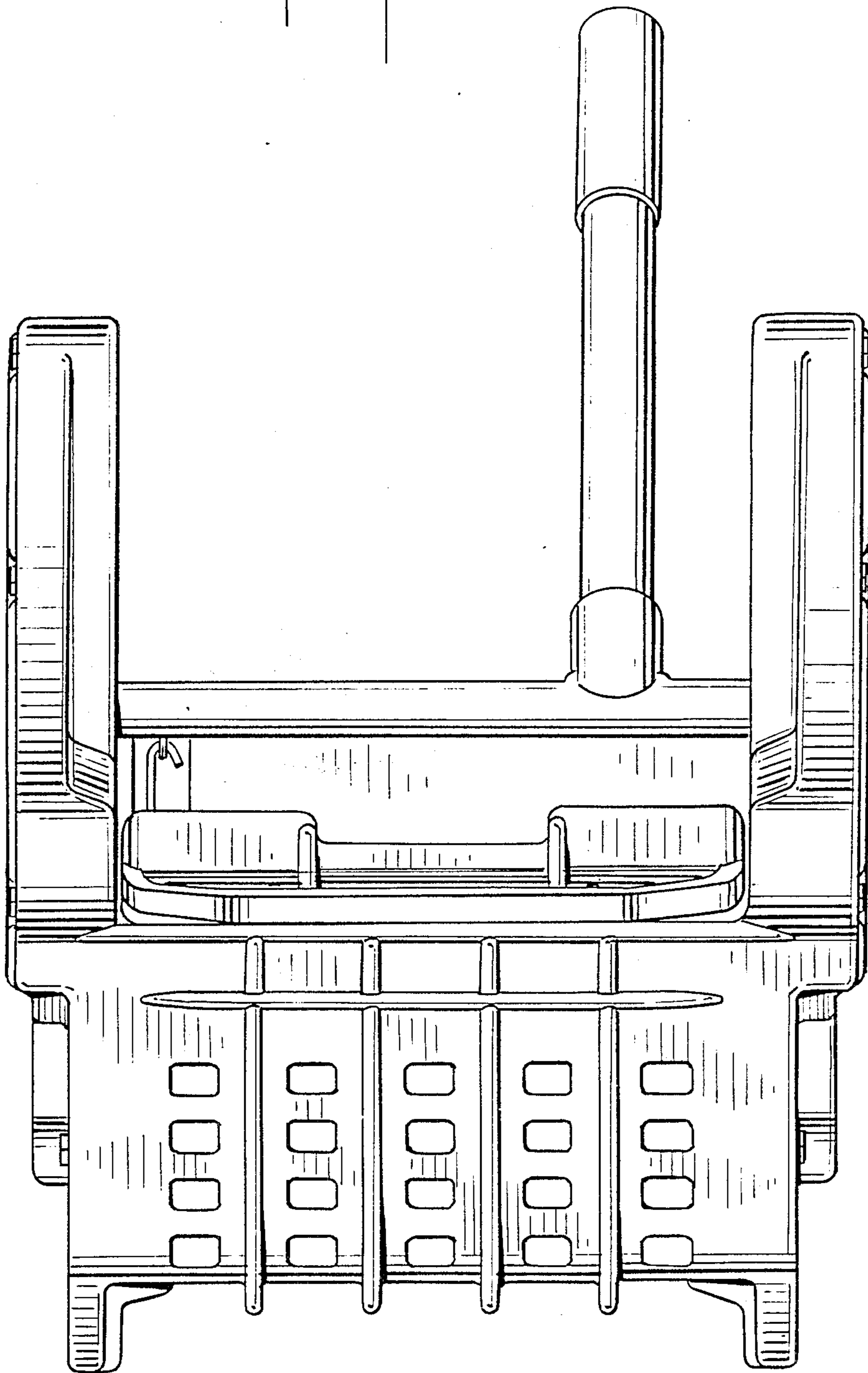

Fig. 4.

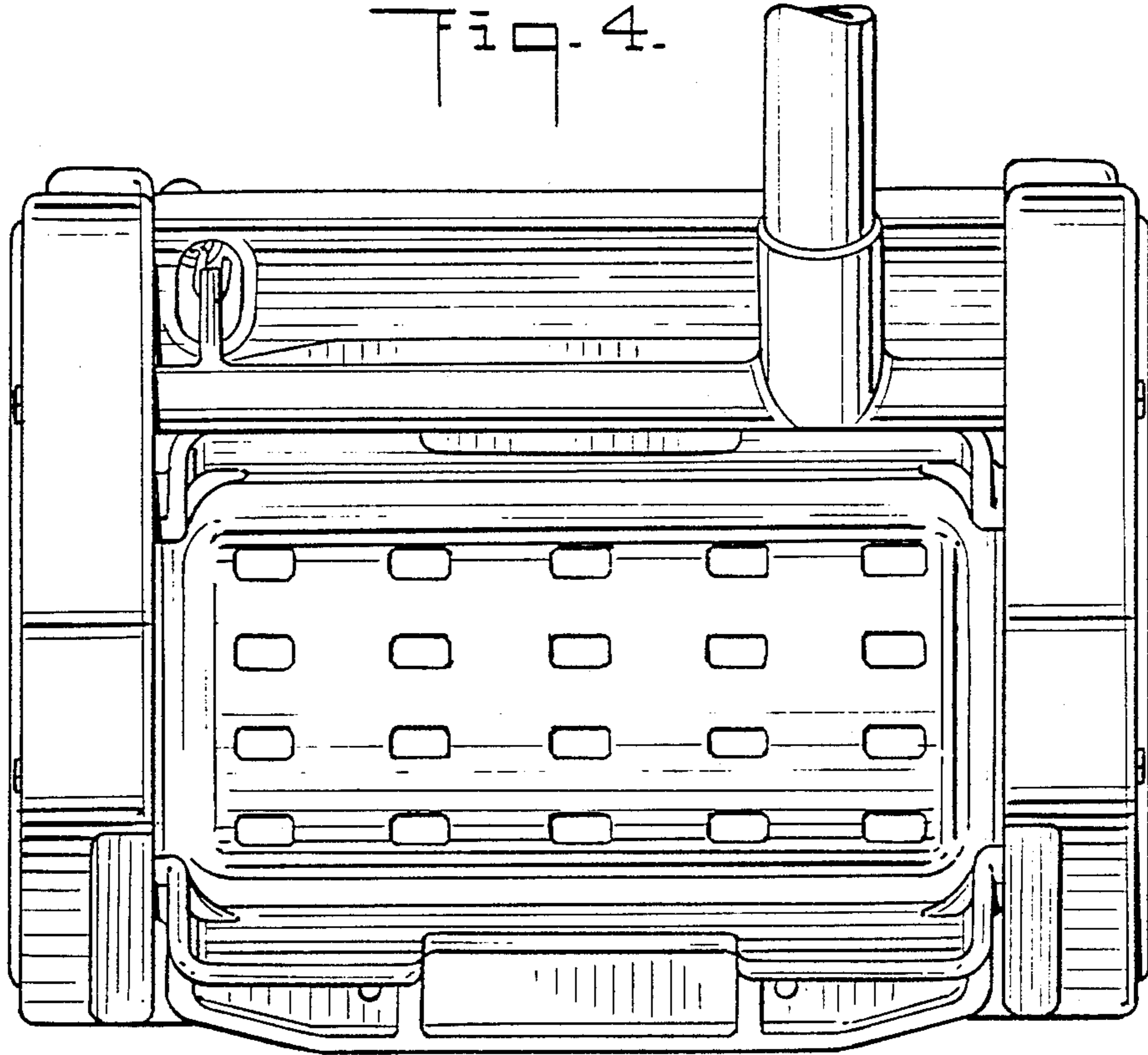

Fig. 5.

