

[54] REAR TRUNK LID FOR AUTOMOTIVE VEHICLE

[75] Inventor: Ermanno Cressoni, Arese, Italy

[73] Assignee: Alfa Romeo Auto S.p.A., Naples, Italy

[\*\*] Term: 14 Years

[21] Appl. No.: 729,157

[22] Filed: Apr. 30, 1985

[30] Foreign Application Priority Data

Oct. 31, 1984 [IT] Italy ..... 23665/84[U]  
[52] U.S. Cl. .... D12/196  
[58] Field of Search ..... D12/196; 296/185, 195, 296/197

[56] References Cited

U.S. PATENT DOCUMENTS

D. 246,707 12/1977 Tixier ..... D12/196

OTHER PUBLICATIONS

Car & Driver, 1/84, p. 23, Ford Taurus Rear Trunk Lid, upper right side of page.

Motor Trend, 2/84, p. 38, Rear Hatch Door of Plymouth Voyager, top of page.

Road & Track, 4/84, pp. 82 & 83, Audi, 5000 S Rear Trunk Lid.

Car & Driver, 4/84, p. 61, Rear Trunk Lid of Maserati Biturbo, center of page.

Primary Examiner—James M. Gandy

Attorney, Agent, or Firm—Charles E. Brown; Charles A. Brown

[57] CLAIM

The ornamental design for a rear trunk lid for automotive vehicle, as shown.

DESCRIPTION

FIG. 1 is a front elevation view of a rear trunk lid for automotive vehicle showing my new design looking in the direction of arrow 1 in FIG. 2;

FIG. 2 is a top plan view thereof;

FIG. 3 is a side elevation view thereof looking in the direction of arrow 3 in FIG. 2;

FIG. 4 is a side elevation view thereof looking in the direction of arrow 4 in FIG. 2;

FIG. 5 is a bottom plan view thereof;

FIG. 6 is a rear elevation view thereof looking in the direction of arrow 6 in FIG. 2;

FIG. 7 is a bottom perspective view thereof.

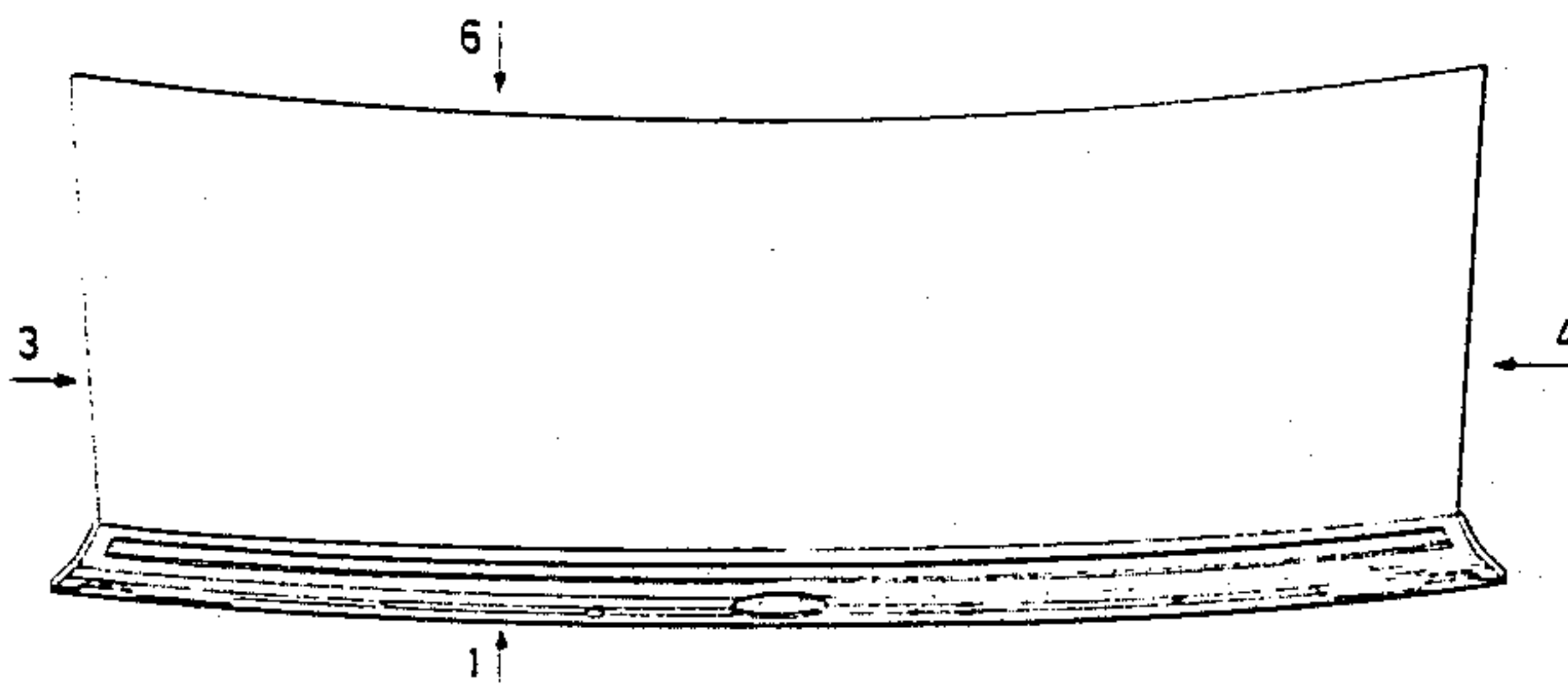
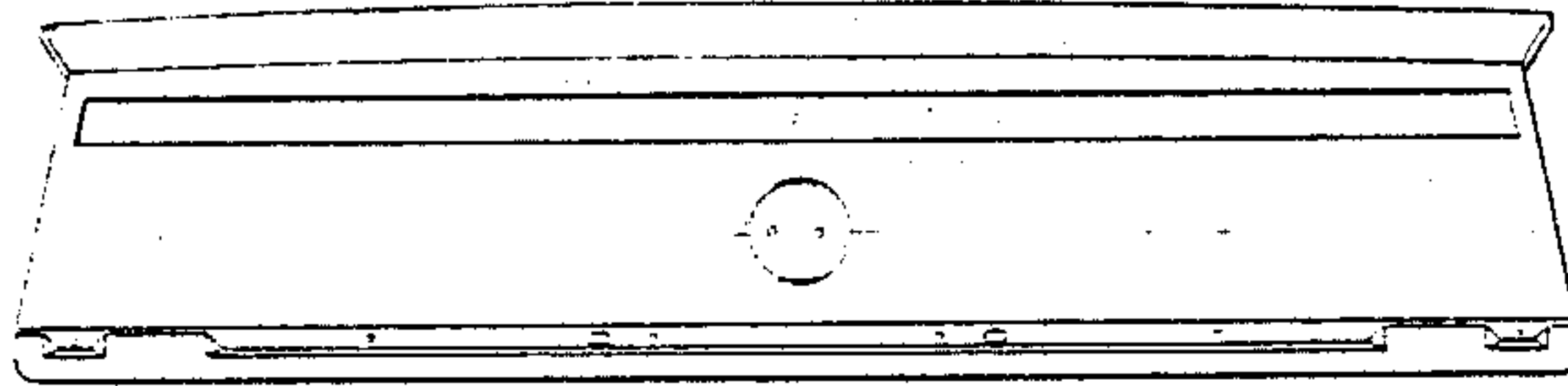

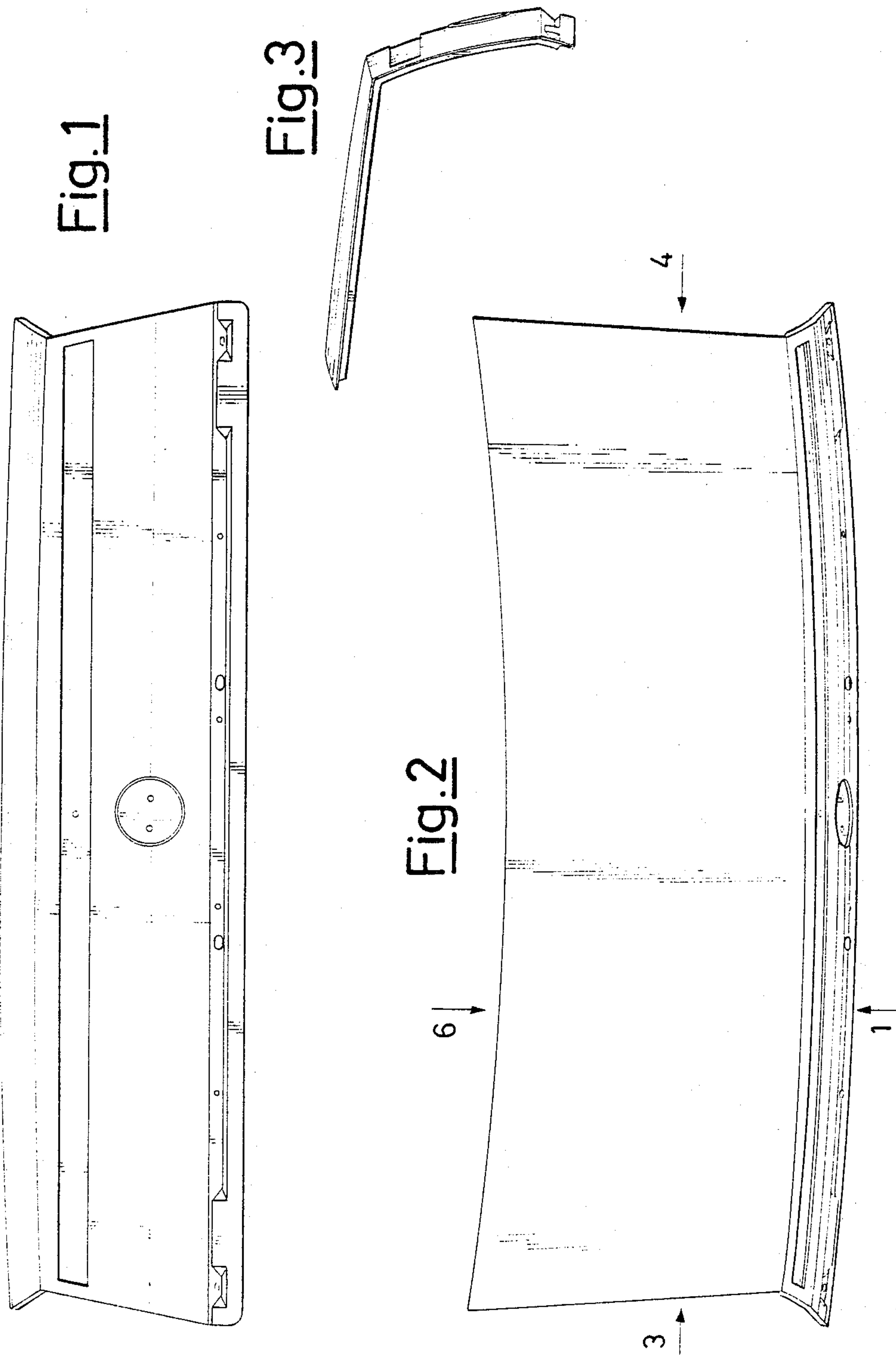

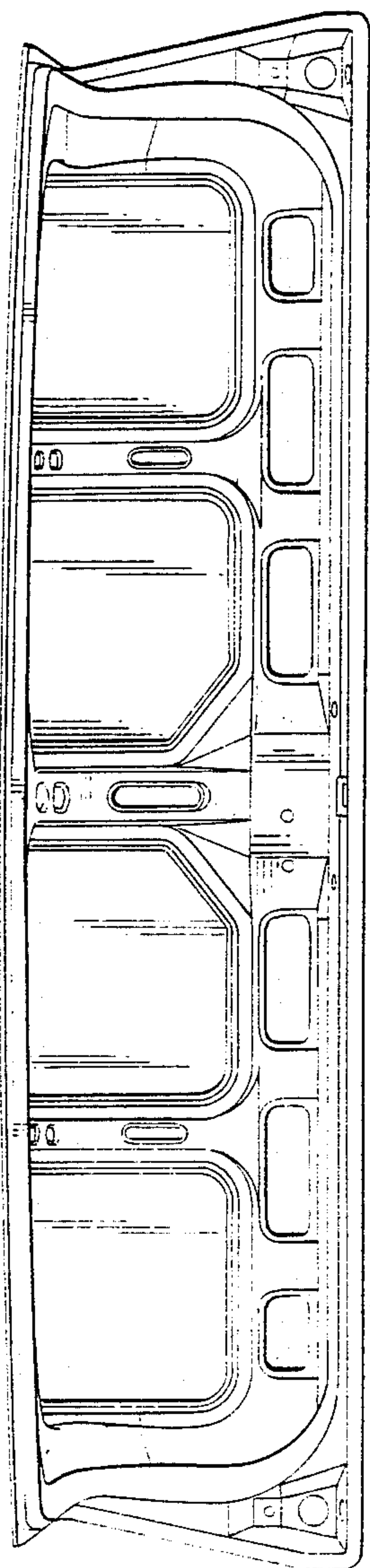

Fig. 6

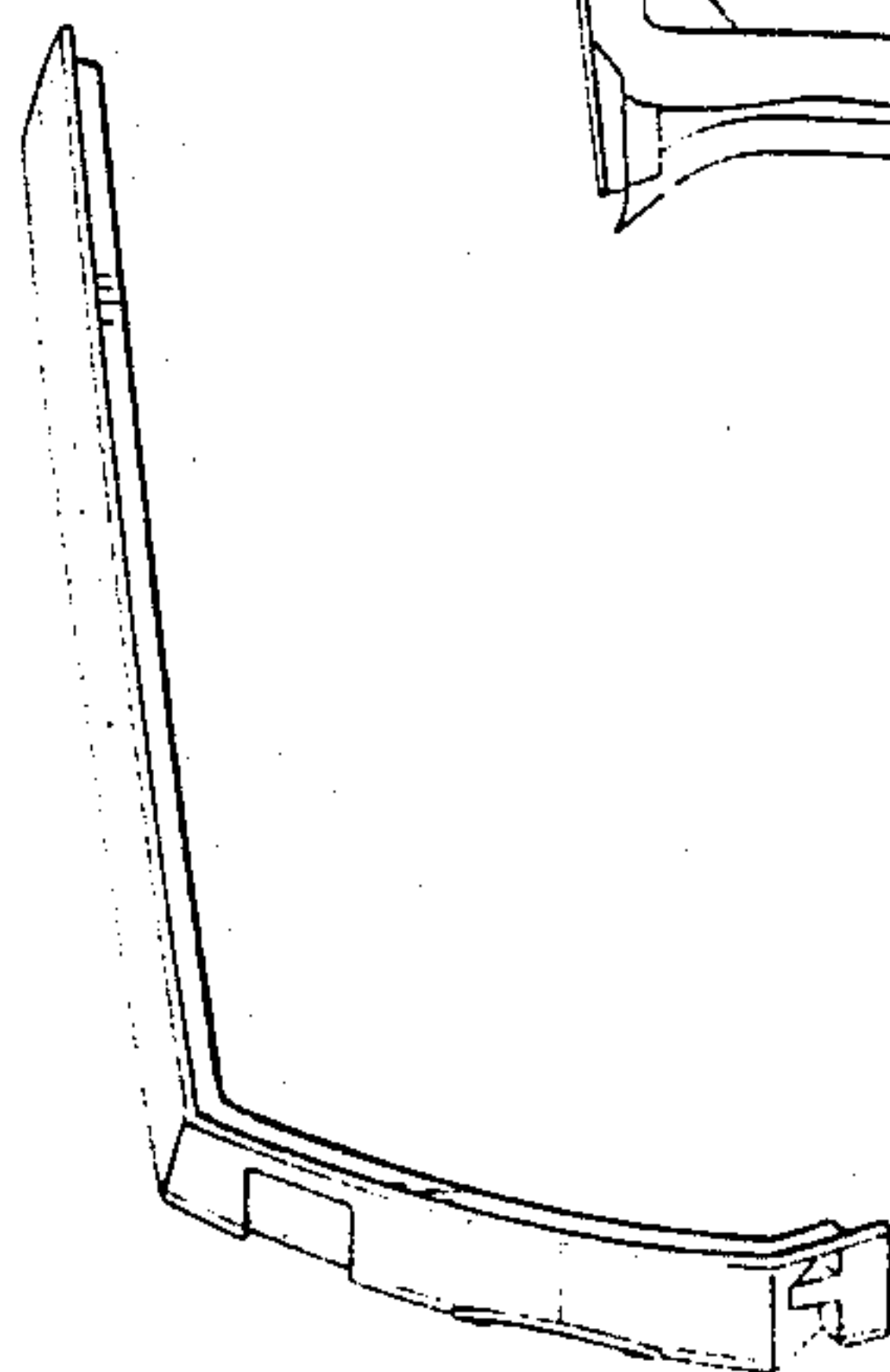

Fig. 4

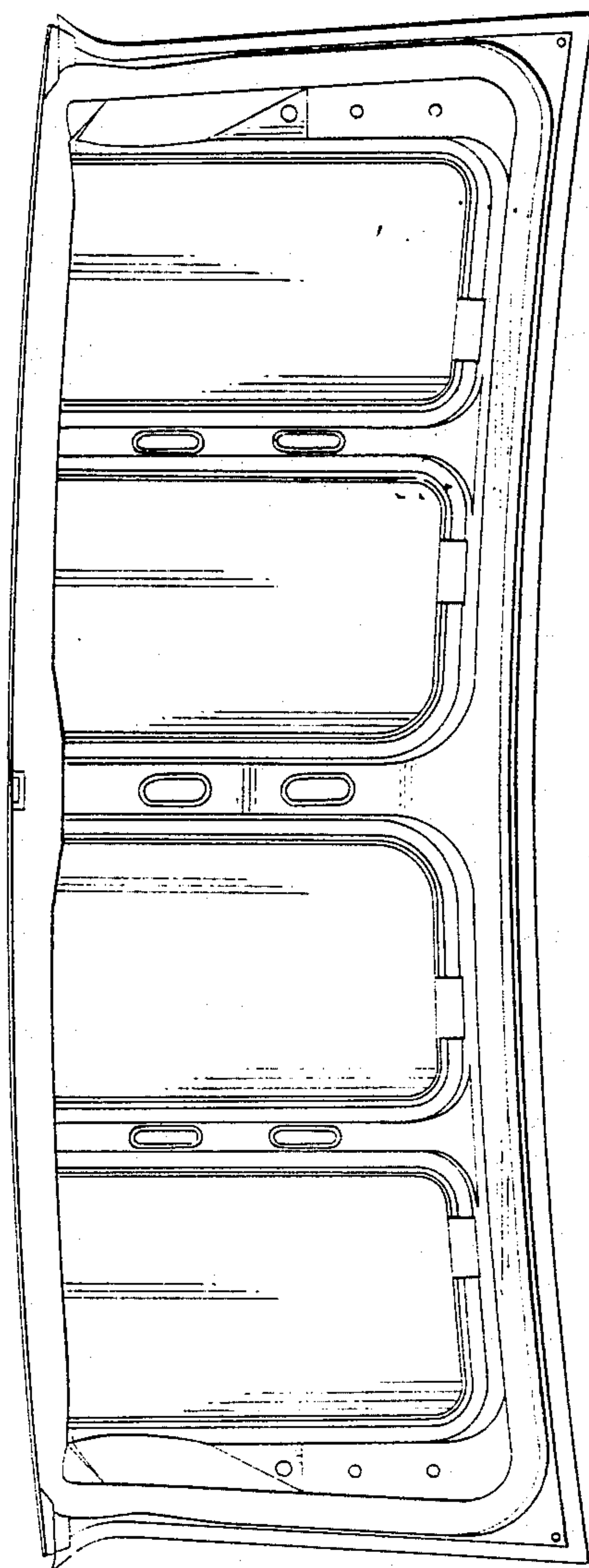

Fig. 5

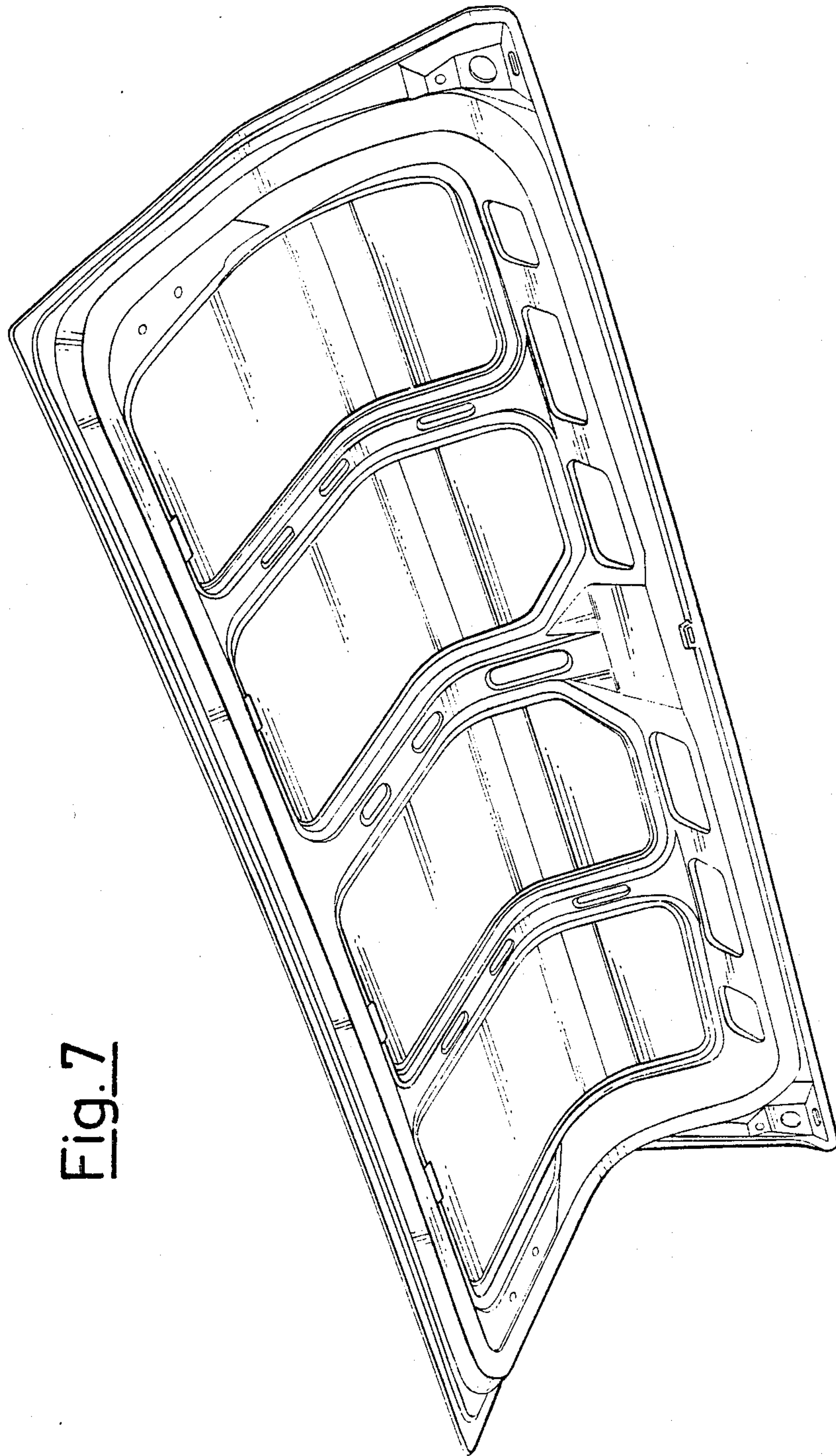

Fig. 7