

[54] TRUCK-MOUNTED VAN BODY FOR WIRELINE DEPLOYMENT AND RETRIEVAL APPARATUS

[75] Inventors: John A. Peterson, Brigham City; Robert L. Burton, Kaysville, both of Utah

[73] Assignee: Phoenix Dataline Incorporated, Salt Lake City, Utah

[**] Term: 14 Years

[21] Appl. No.: 738,856

[22] Filed: May 29, 1985

[52] U.S. Cl. D12/96

[58] Field of Search D12/93, 96; 242/86.5 R; 296/183

[56] References Cited

U.S. PATENT DOCUMENTS

- D. 141,085 5/1945 Powers D12/96
- D. 162,658 3/1951 Holan et al. D12/96
- D. 190,415 5/1961 Powers D12/96

D. 255,228 6/1980 Sauber D12/96

Primary Examiner—James M. Gandy
Attorney, Agent, or Firm—A. Ray Osburn

[57] CLAIM

The ornamental design for a truck-mounted van body for wireline deployment and retrieval apparatus, as shown and described.

DESCRIPTION

FIG. 1 is a top right rear perspective view of a truck-mounted van body for wireline deployment and retrieval apparatus showing our new design, it being understood that the broken lines are for illustrative purposes only and form no part of the design claimed; FIG. 2 is an enlarged front elevation view thereof; FIG. 3 is an enlarged right side elevation view thereof; FIG. 4 is an enlarged rear perspective view thereof; FIG. 5 is an enlarged left side elevation view thereof; FIG. 6 is an enlarged top perspective view thereof; and FIG. 7 a perspective view similar to that of FIG. 1, with the rear doors and roof panel being shown in open condition.

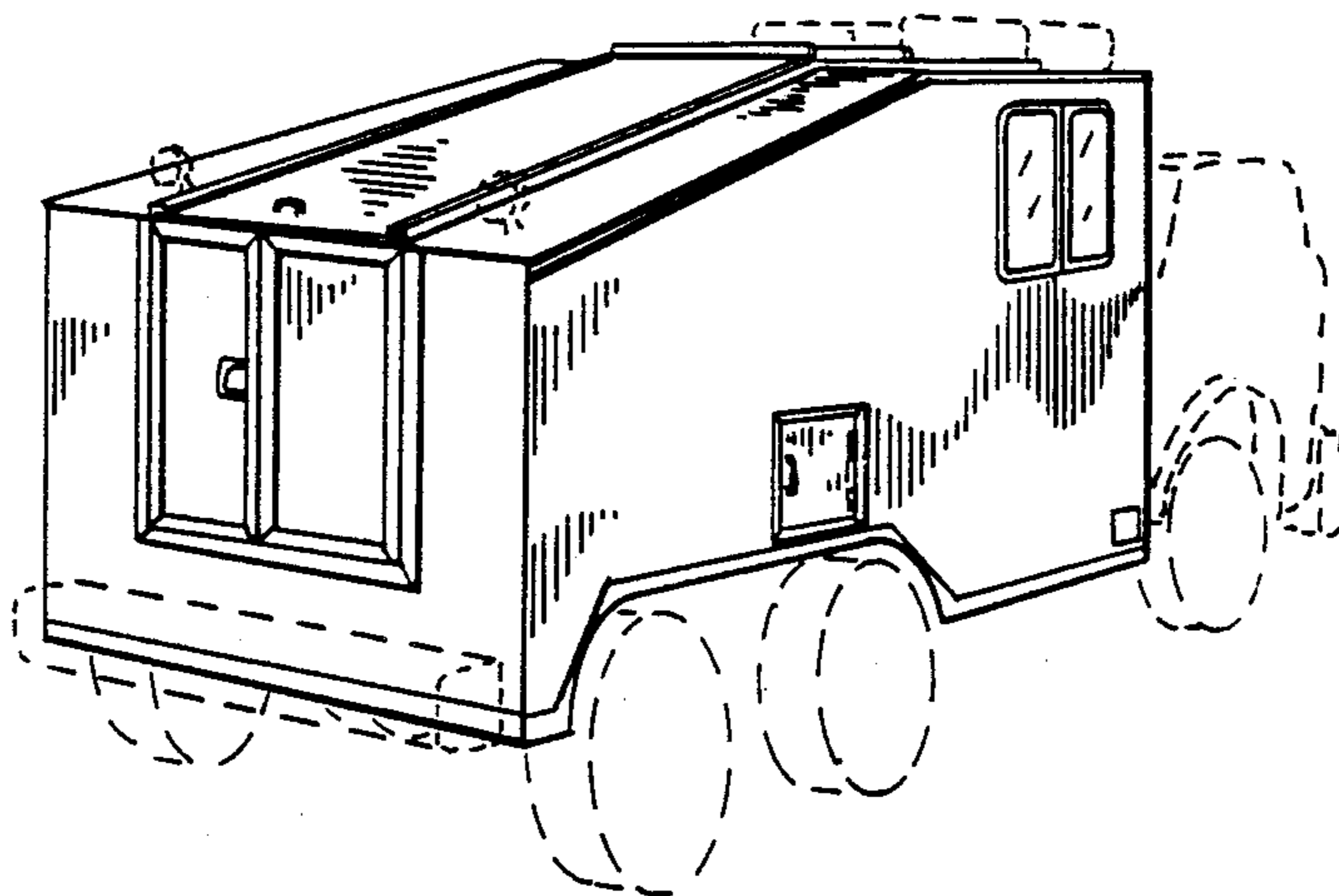

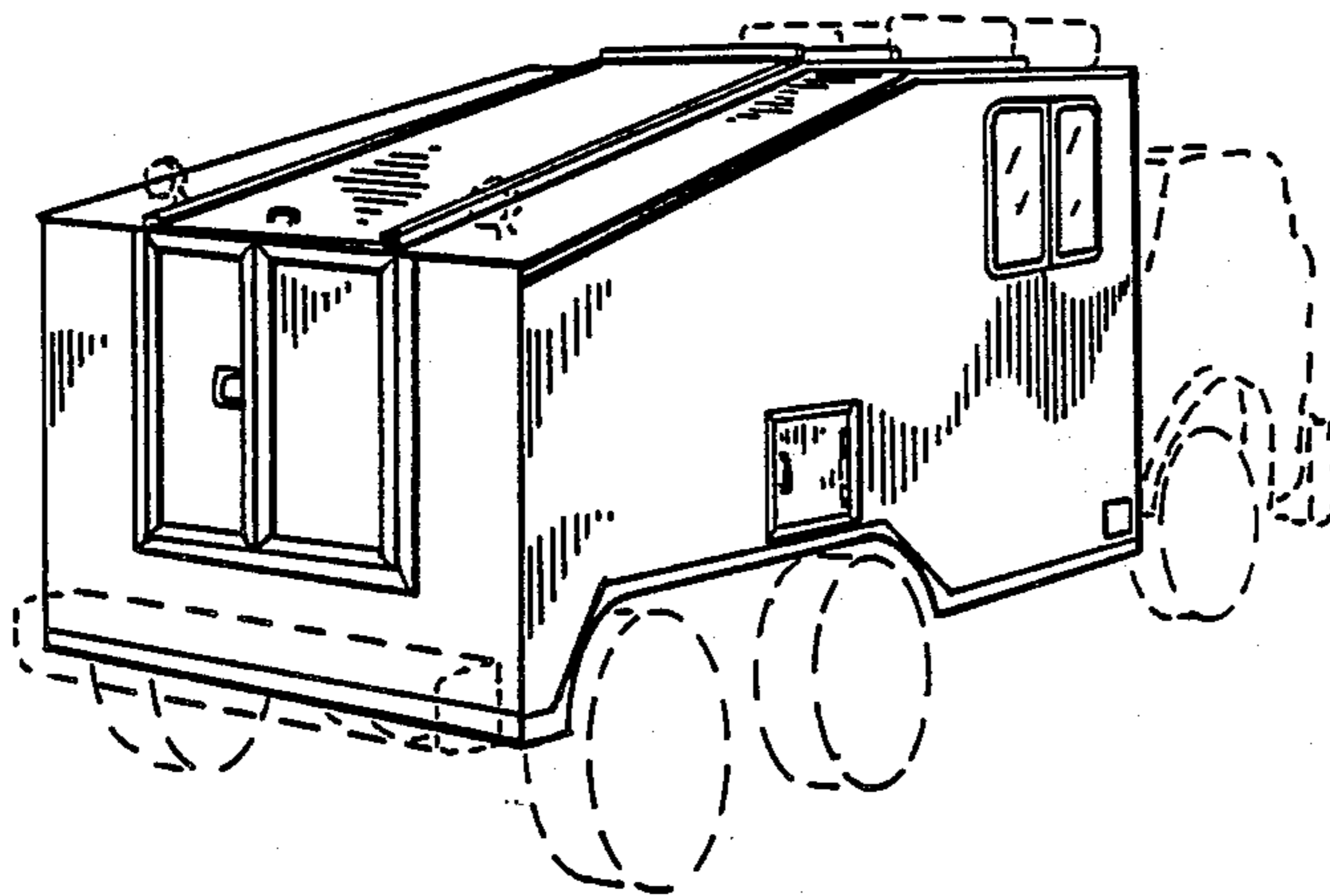

FIG. 1

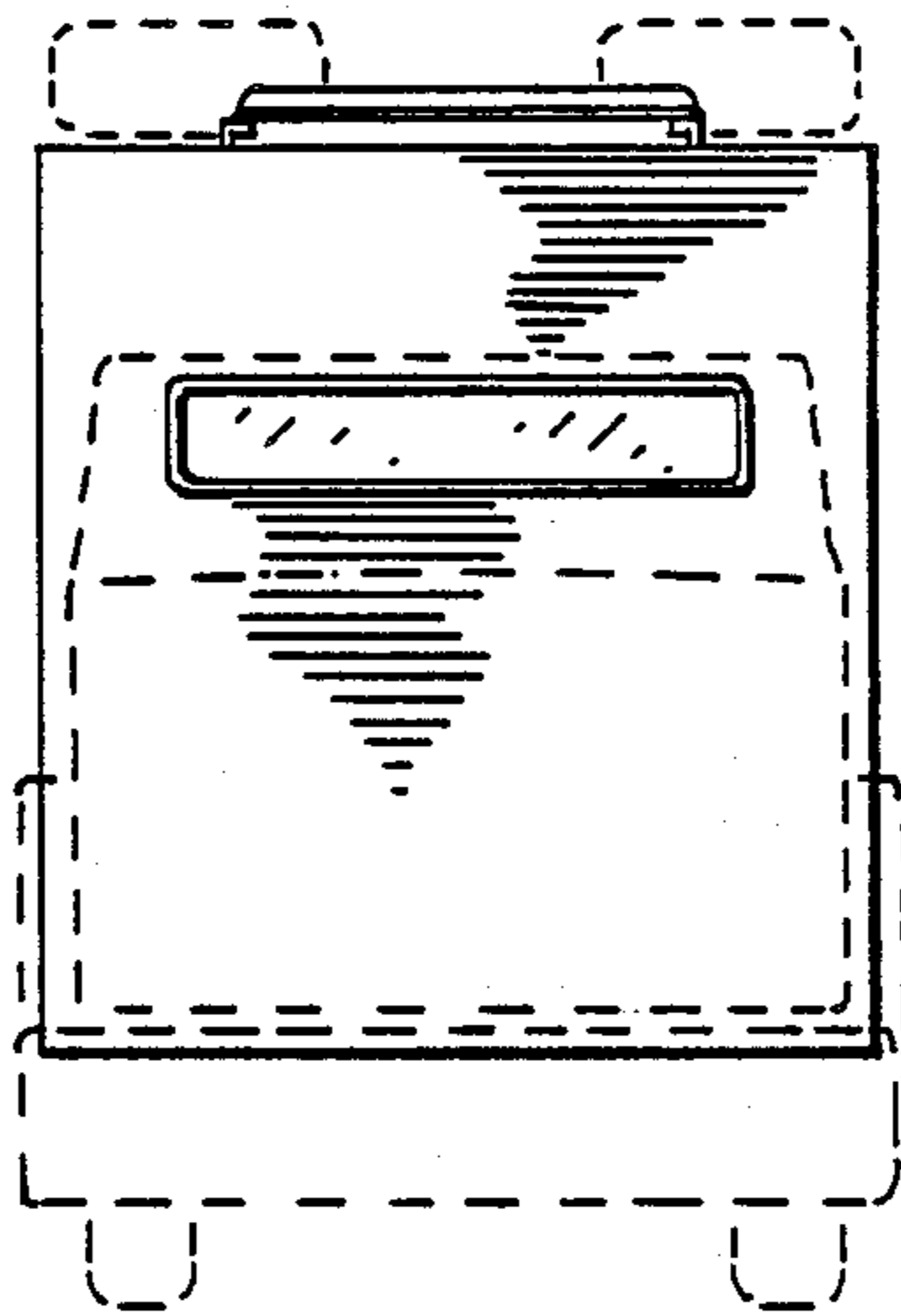

FIG. 2

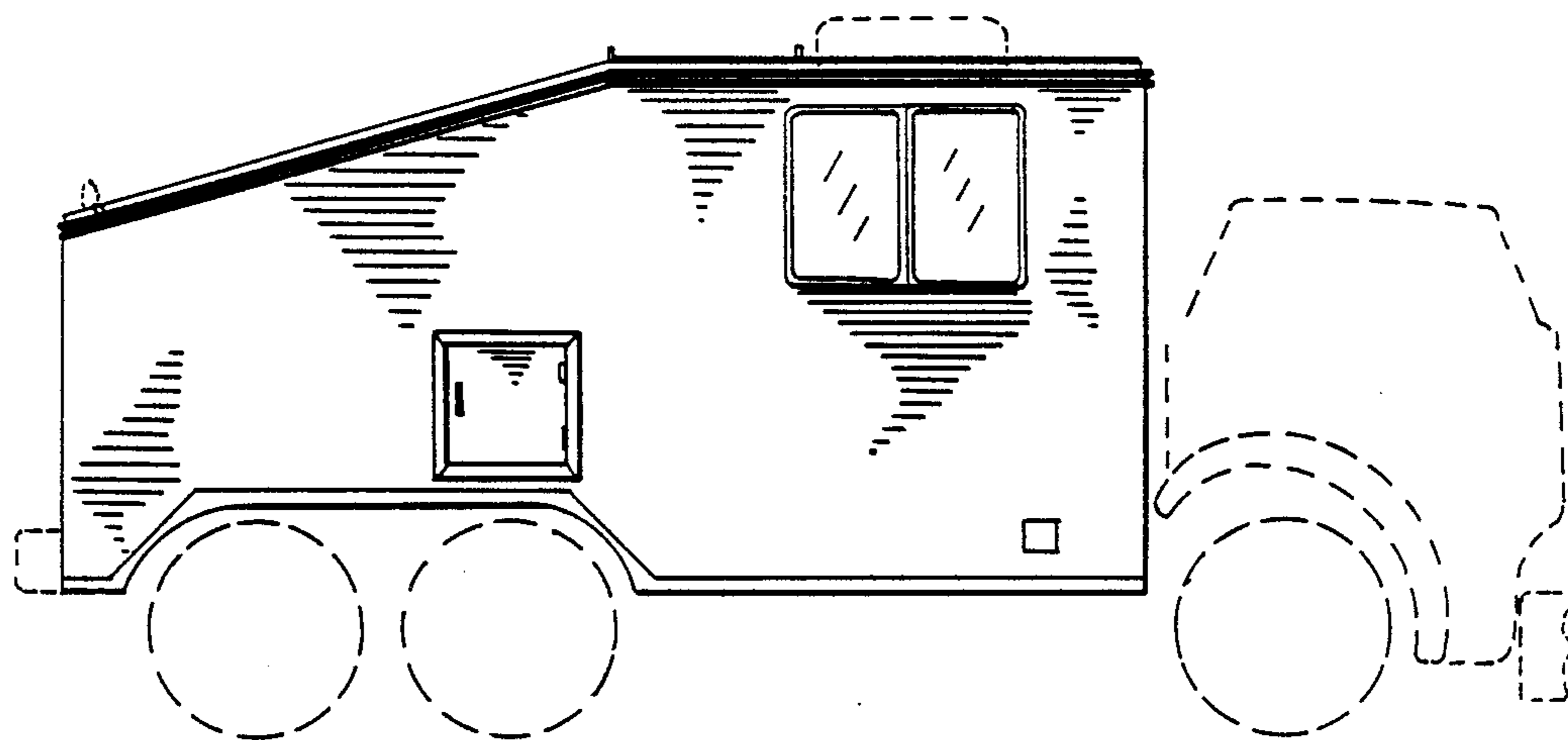

FIG. 3

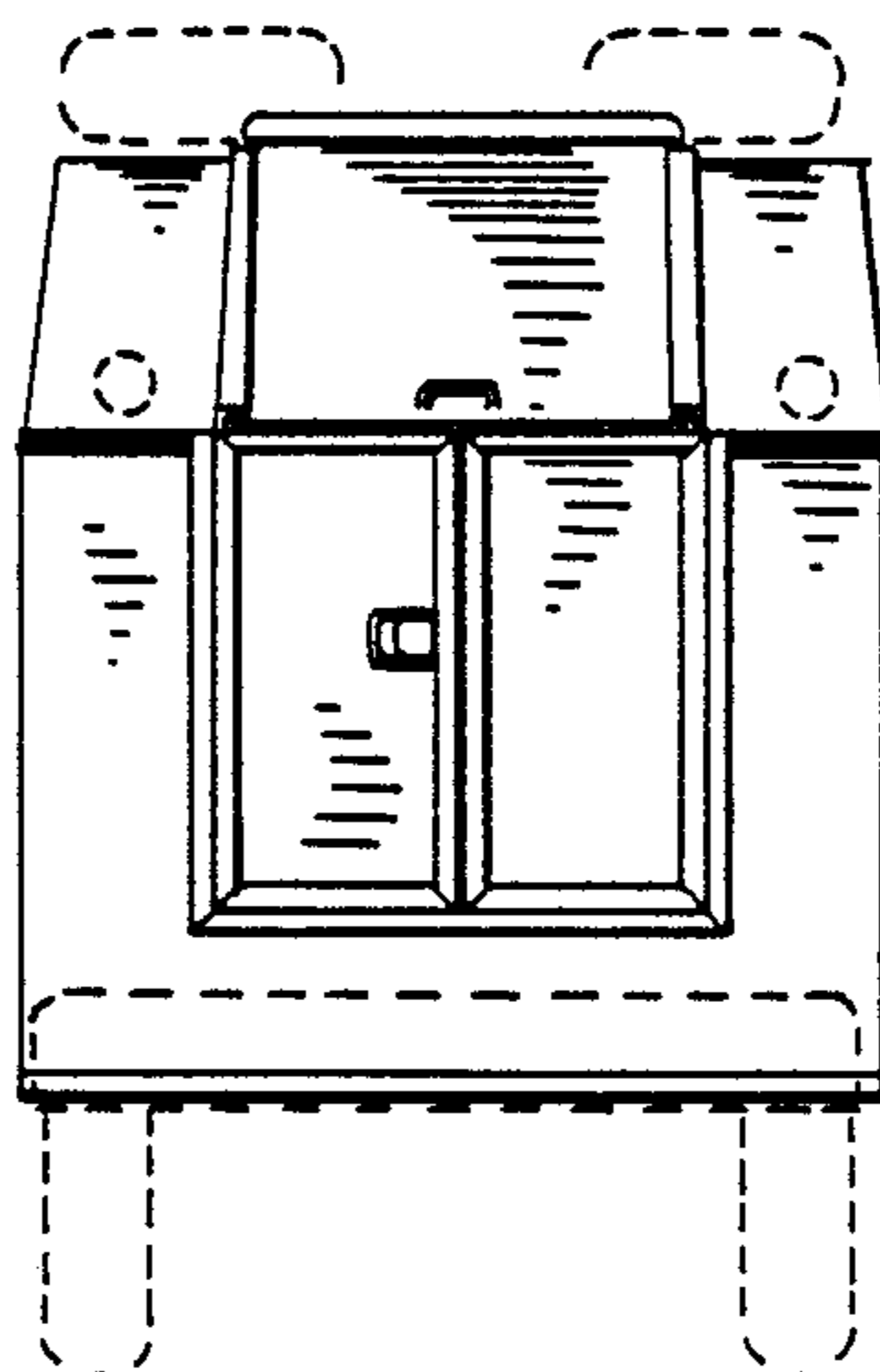

FIG. 4

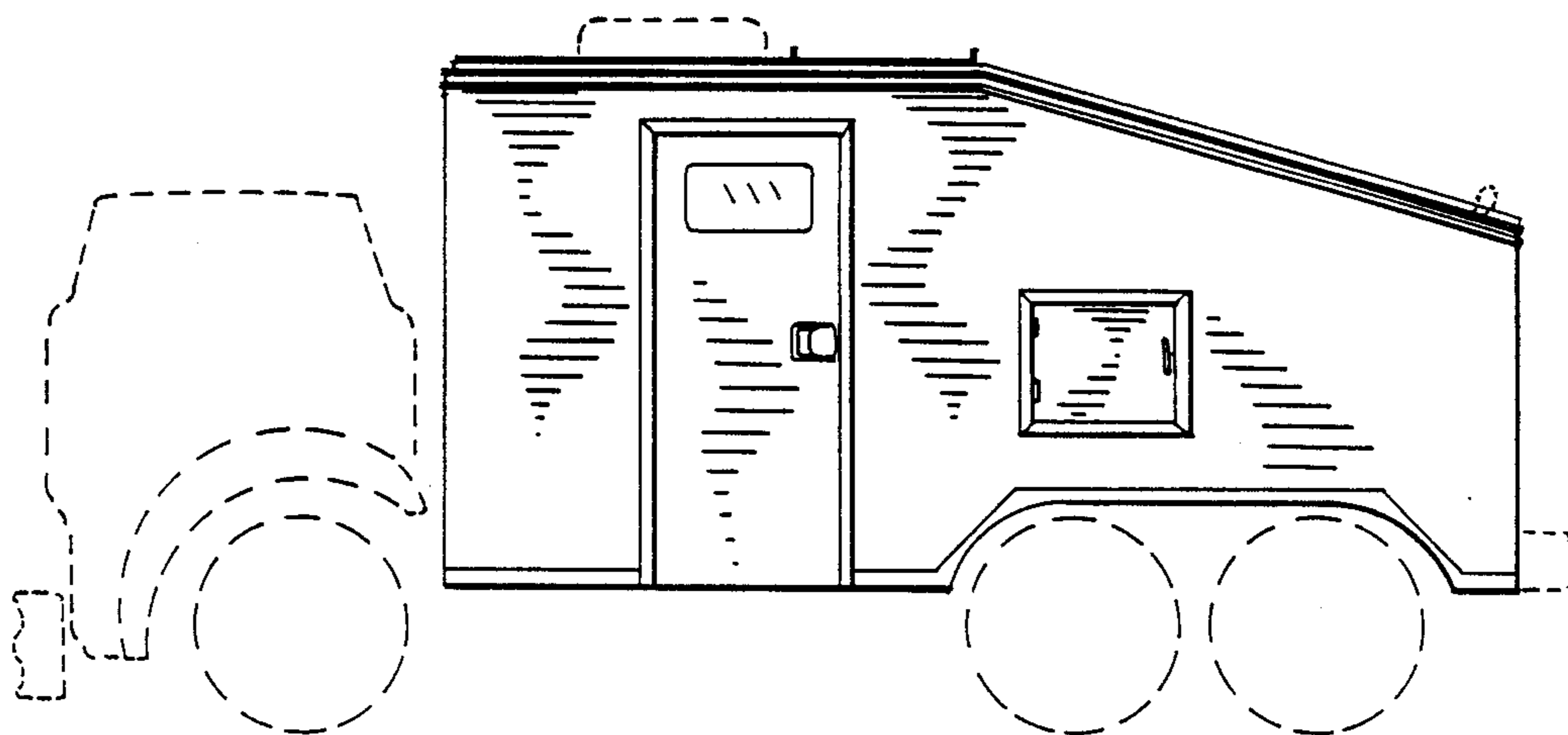

FIG. 5

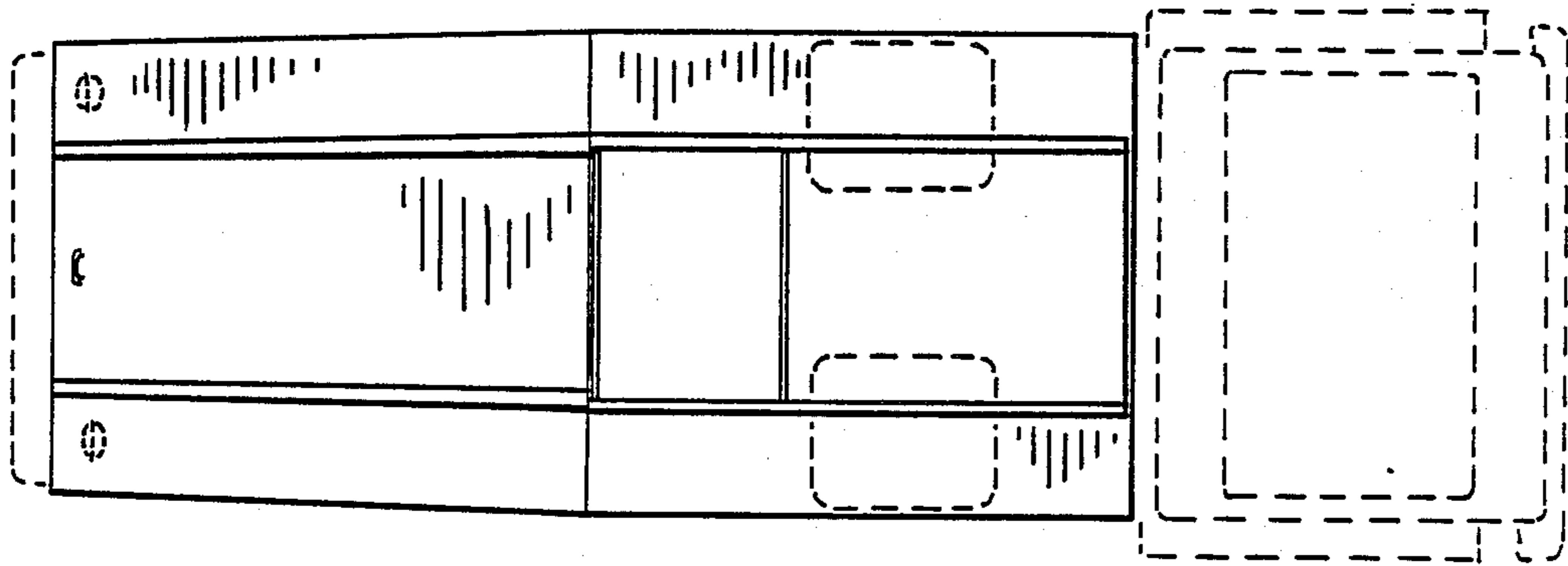

FIG. 6

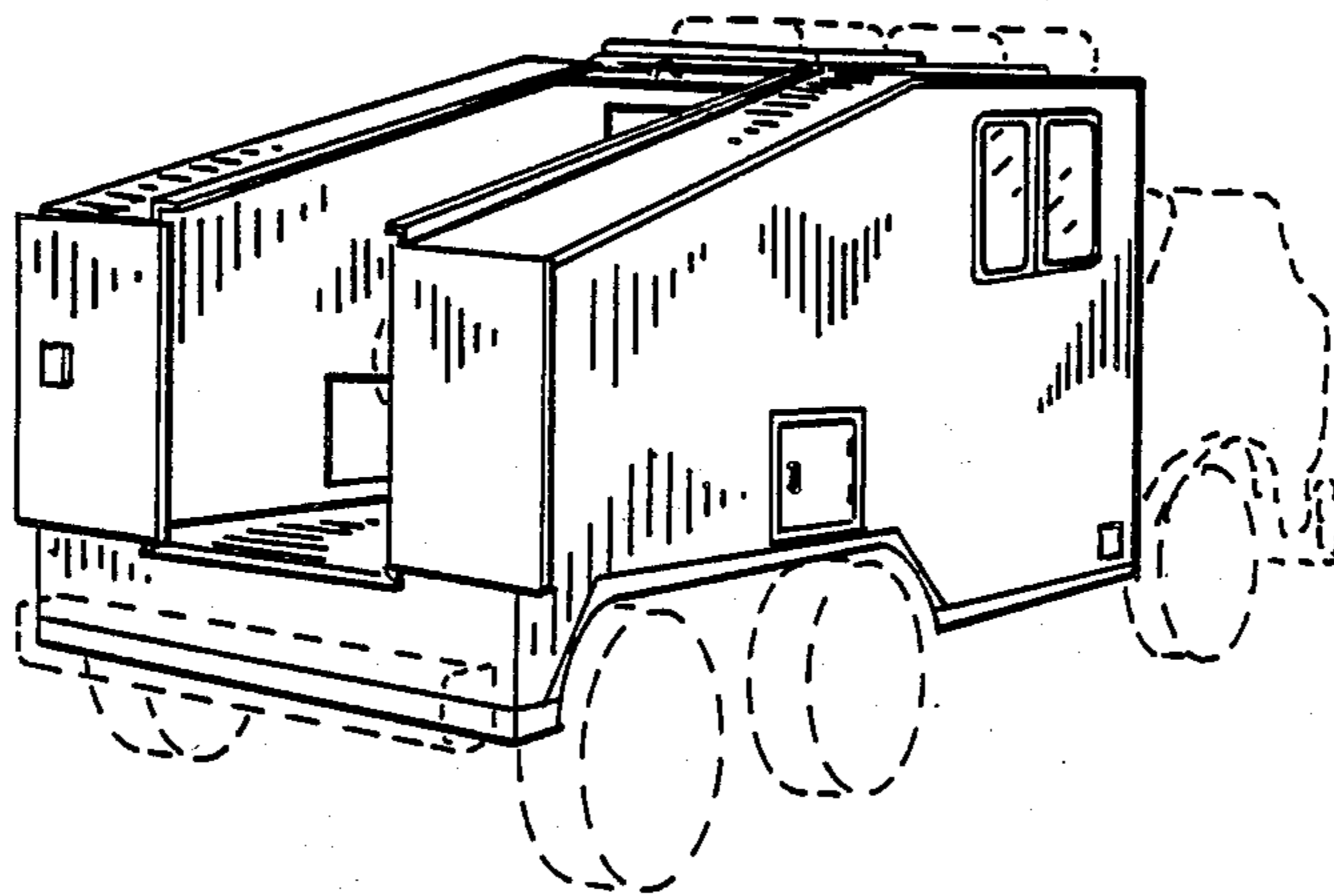

FIG. 7