

[54] ELECTRIC LANTERN

[76] Inventors: David P. Witusik, P.O. Box 115, R.R. #6; Brian W. Sanford, 6710 Dix Rd., P.O. Box 98, both of Rome, N.Y. 13440

[\*\*] Term: 14 Years

[21] Appl. No.: 763,185

[22] Filed: Aug. 7, 1985

[52] U.S. Cl. .... D26/41

[58] Field of Search ..... D26/37-50; 362/157, 158, 183-208

[56] References Cited

U.S. PATENT DOCUMENTS

- D. 232,185 7/1974 Rhoades et al. .... D26/41
- D. 266,997 11/1982 Hsue ..... D26/37 X
- 2,765,481 10/1956 Manhart et al. .... D26/40 X
- 3,274,382 9/1966 Fattori ..... 362/199 X

FOREIGN PATENT DOCUMENTS

- 501723 3/1939 United Kingdom ..... 362/192
- 1030494 5/1966 United Kingdom ..... 362/191
- 1109622 4/1968 United Kingdom ..... 362/188

Primary Examiner—Susan J. Lucas  
Attorney, Agent, or Firm—Wall and Roehrig

[57] CLAIM

The ornamental design for an electric lantern, as shown and described.

DESCRIPTION

FIG. 1 is a perspective view of an electric lantern embodying our new design;  
 FIG. 2 is a front elevational view thereof on an enlarged scale;  
 FIG. 3 is a rear elevational view thereof on an enlarged scale;  
 FIG. 4 is a right side elevational view thereof on an enlarged scale, the left side being a mirror image;  
 FIG. 5 is a top plan view thereof on an enlarged scale;  
 FIG. 6 is a bottom plan view thereof on an enlarged scale.

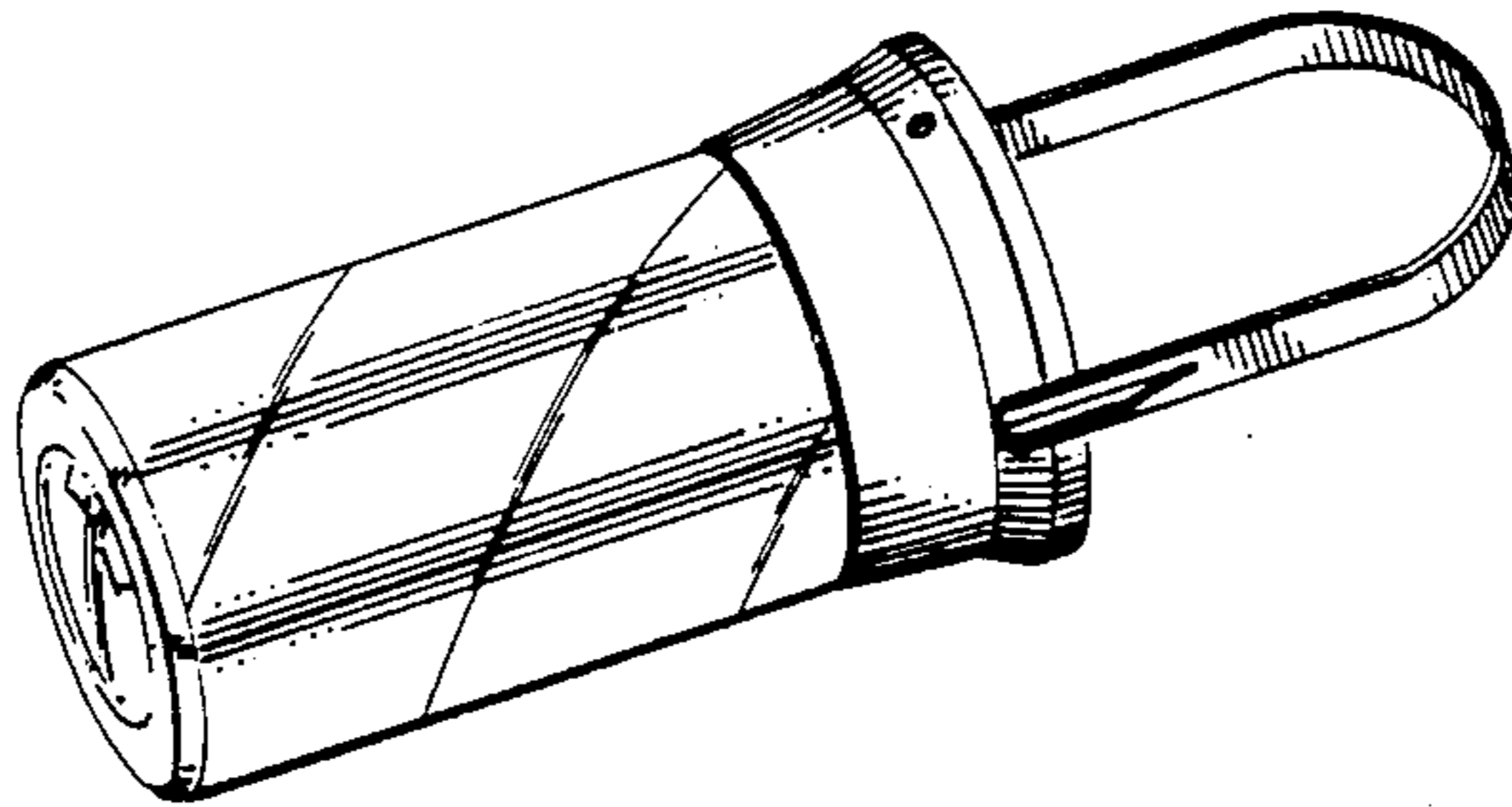

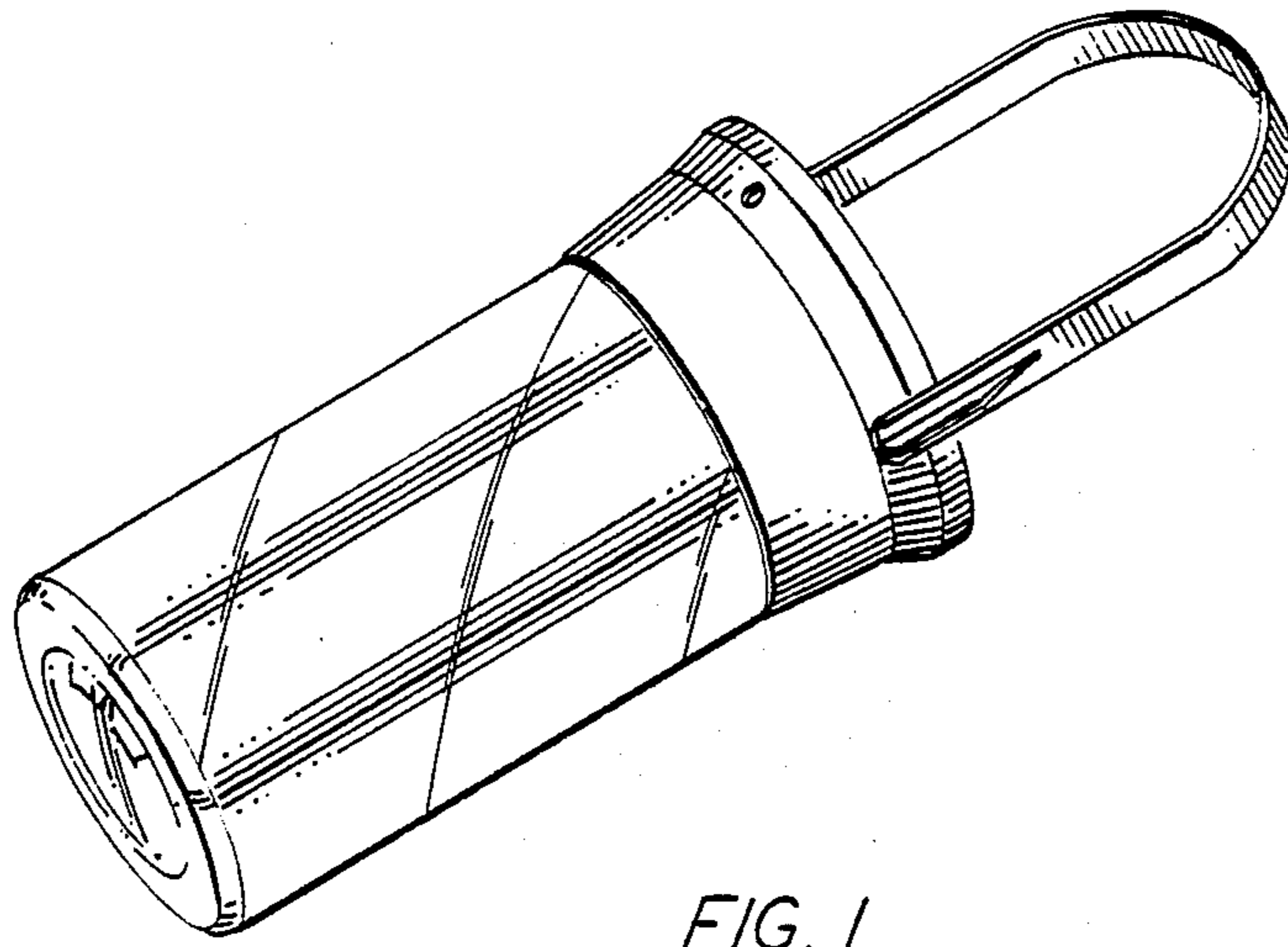

FIG. 1

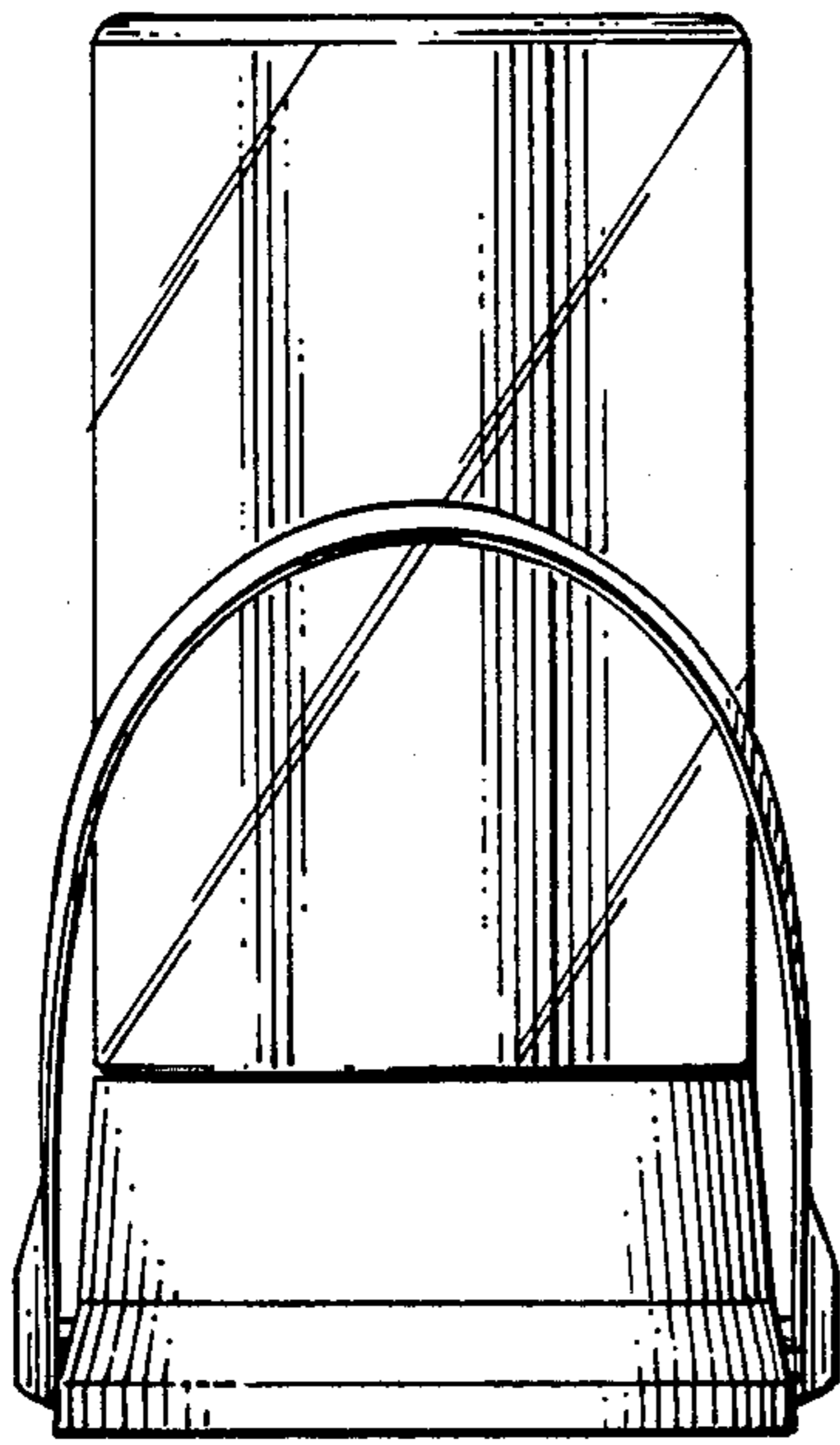

FIG. 2

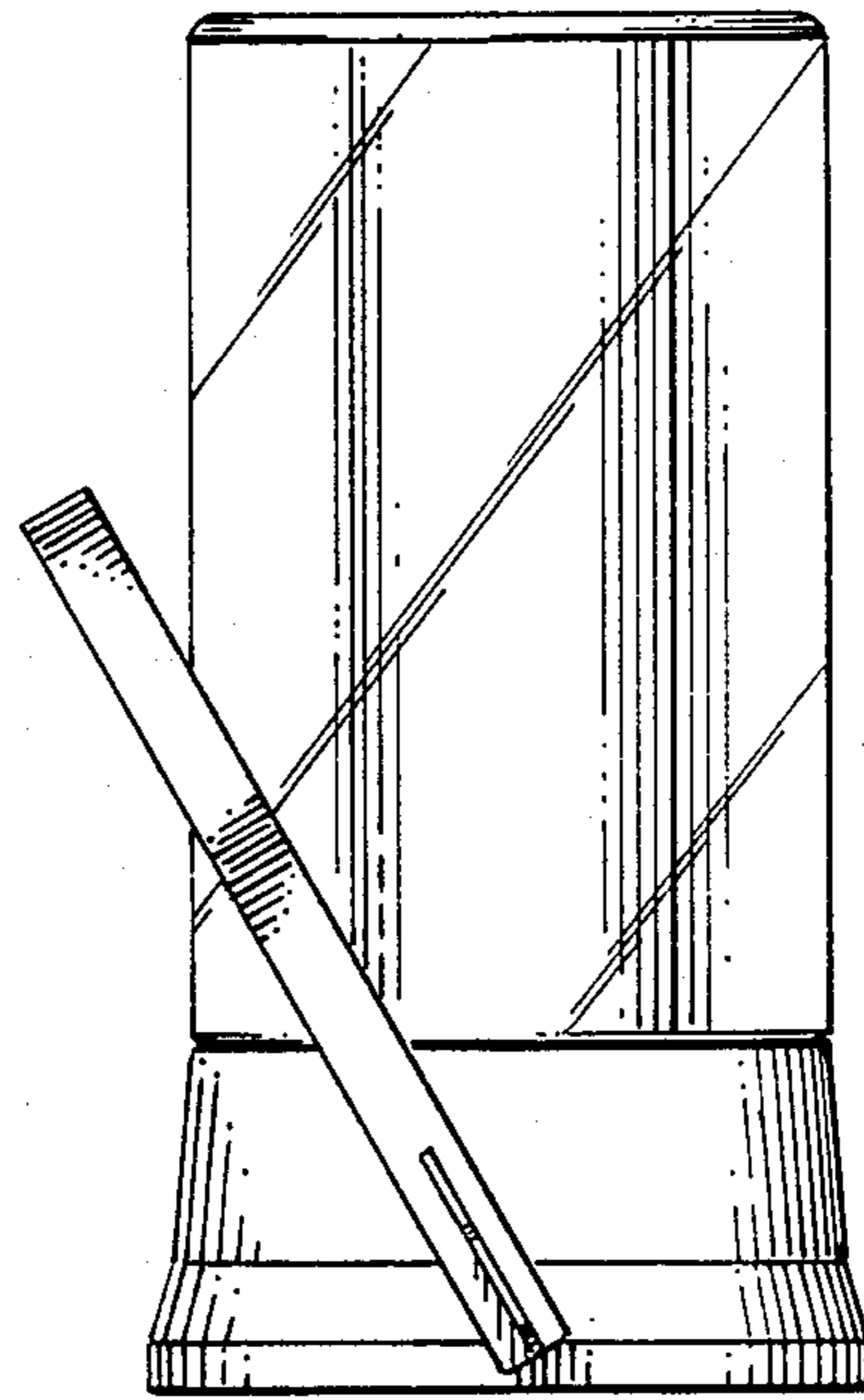

FIG. 4

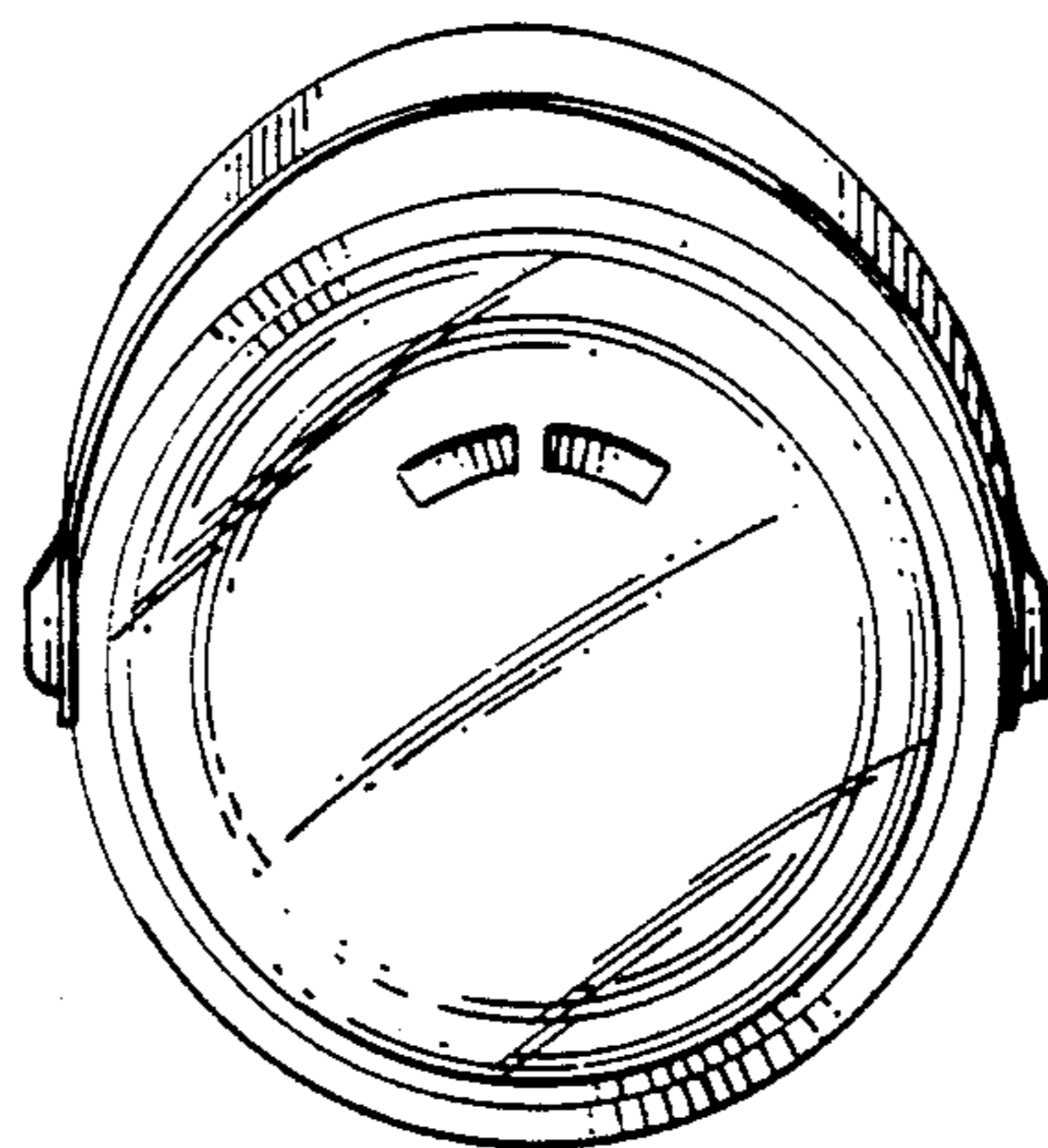

FIG. 5

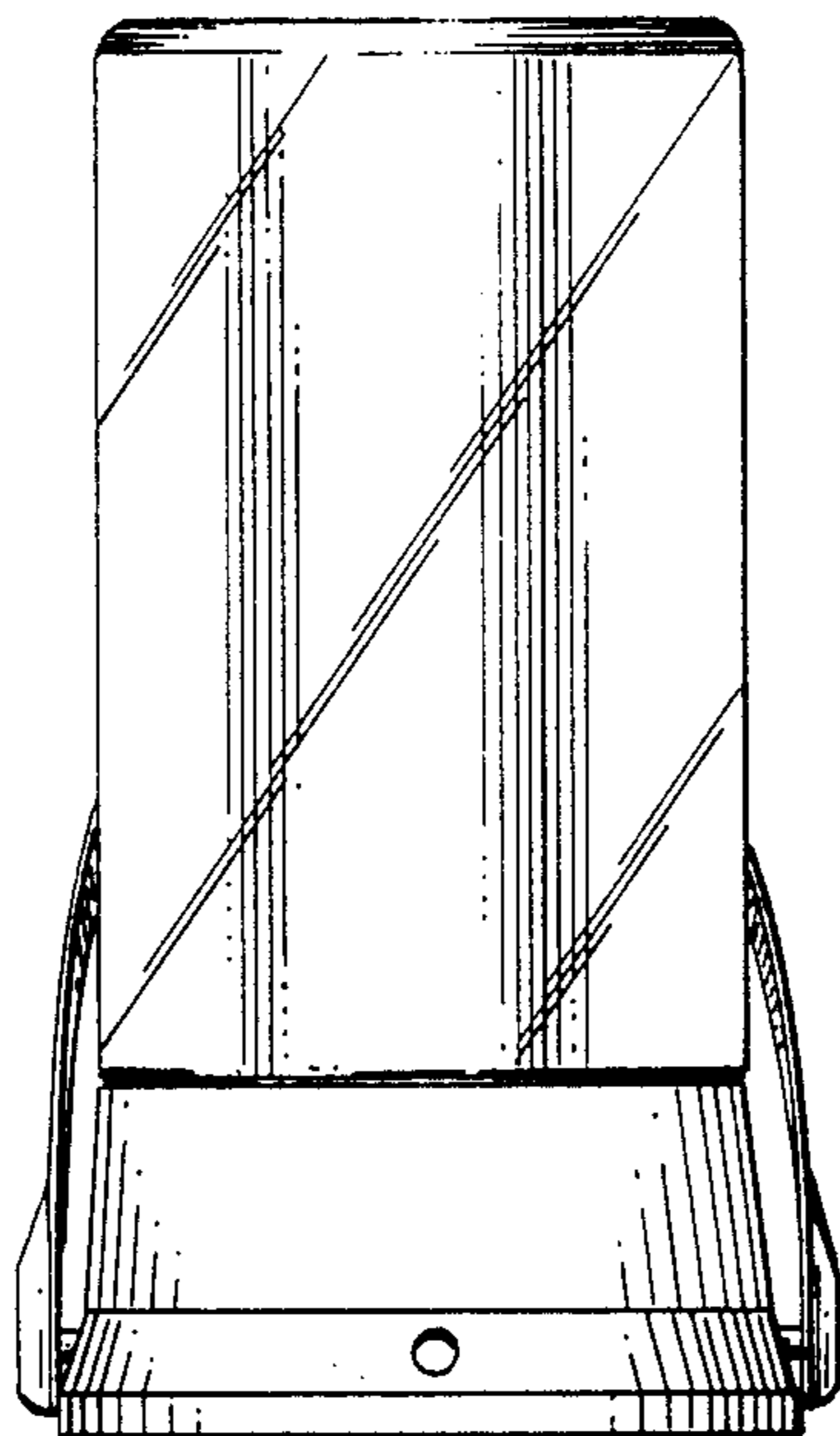

FIG. 3

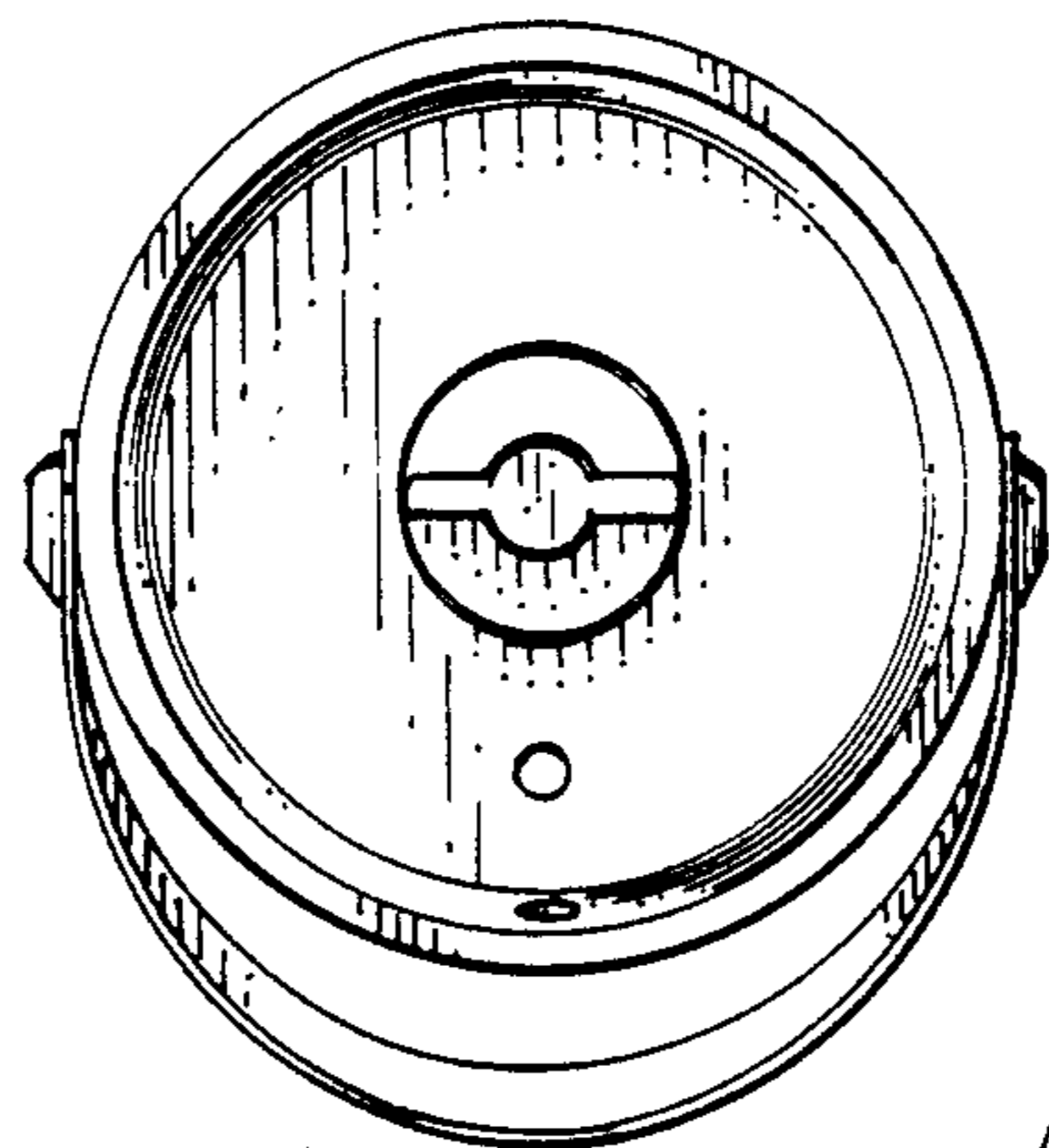

FIG. 6