

[54] SCOOTER

[76] Inventors: Raymond W. Hanna, 32 Knighton Drive, Toronto, Ontario M4A 1W1; Thomas Mulholland, 139 Oakmeadow Blvd., Scarborough, Ontario M1E 4H2, both of Canada

[**] Term: 14 Years

[21] Appl. No.: 872,434

[22] Filed: Jan. 9, 1986

[30] Foreign Application Priority Data

Jan. 2, 1986 [CA] Canada 02-01-86-1

[52] U.S. Cl. D21/81

[58] Field of Search D21/59, 80, 81; 280/87.01, 87.02, 87.04 R, 87.04 A

[56] References Cited

U.S. PATENT DOCUMENTS

D. 174,349 3/1955 Pochard D21/81
D. 253,062 10/1979 Kupka D21/81

D. 253,541 11/1979 Frago D21/81
D. 268,938 5/1983 Carmagnola D21/81
2,045,983 6/1936 Ferrigno 280/87.04 A
2,134,318 10/1938 Ruzich D21/81
3,314,494 4/1967 Weitzner 280/87.04 R

Primary Examiner—Charles A. Rademaker
Attorney, Agent, or Firm—Bachman & LaPointe

[57] CLAIM

The ornamental design for a scooter, as shown and described.

DESCRIPTION

FIG. 1 is a front perspective view of a scooter showing our new design;
FIG. 2 is a front perspective view of a modified form of the design shown in FIG. 1;
FIG. 3 is a front elevational view of the design shown in FIG. 1;
FIG. 4 is a rear elevational view thereof;
FIG. 5 is a top plan view thereof;
FIG. 6 is a left side elevational view thereof; and
FIG. 7 is a bottom plan view thereof.

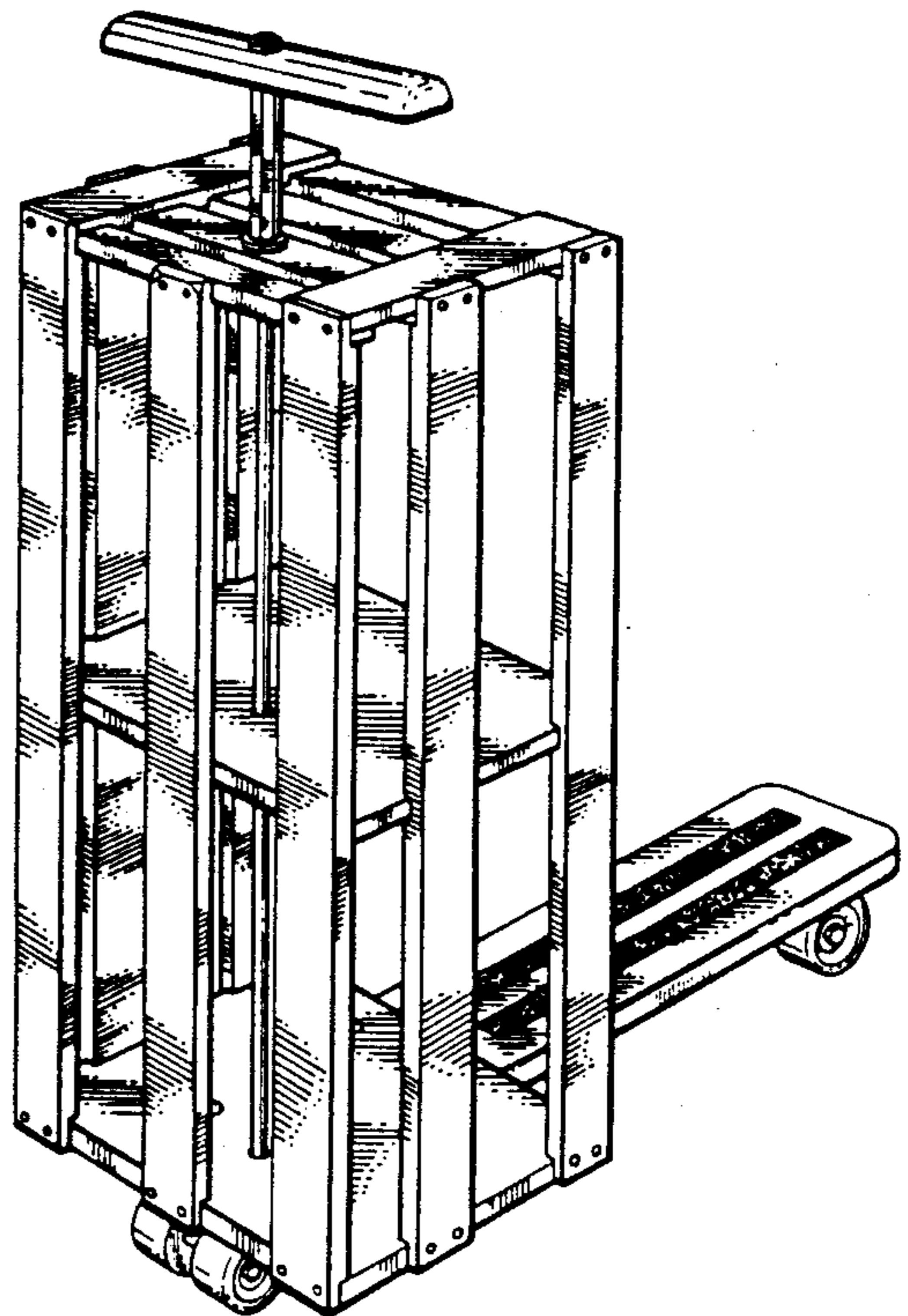
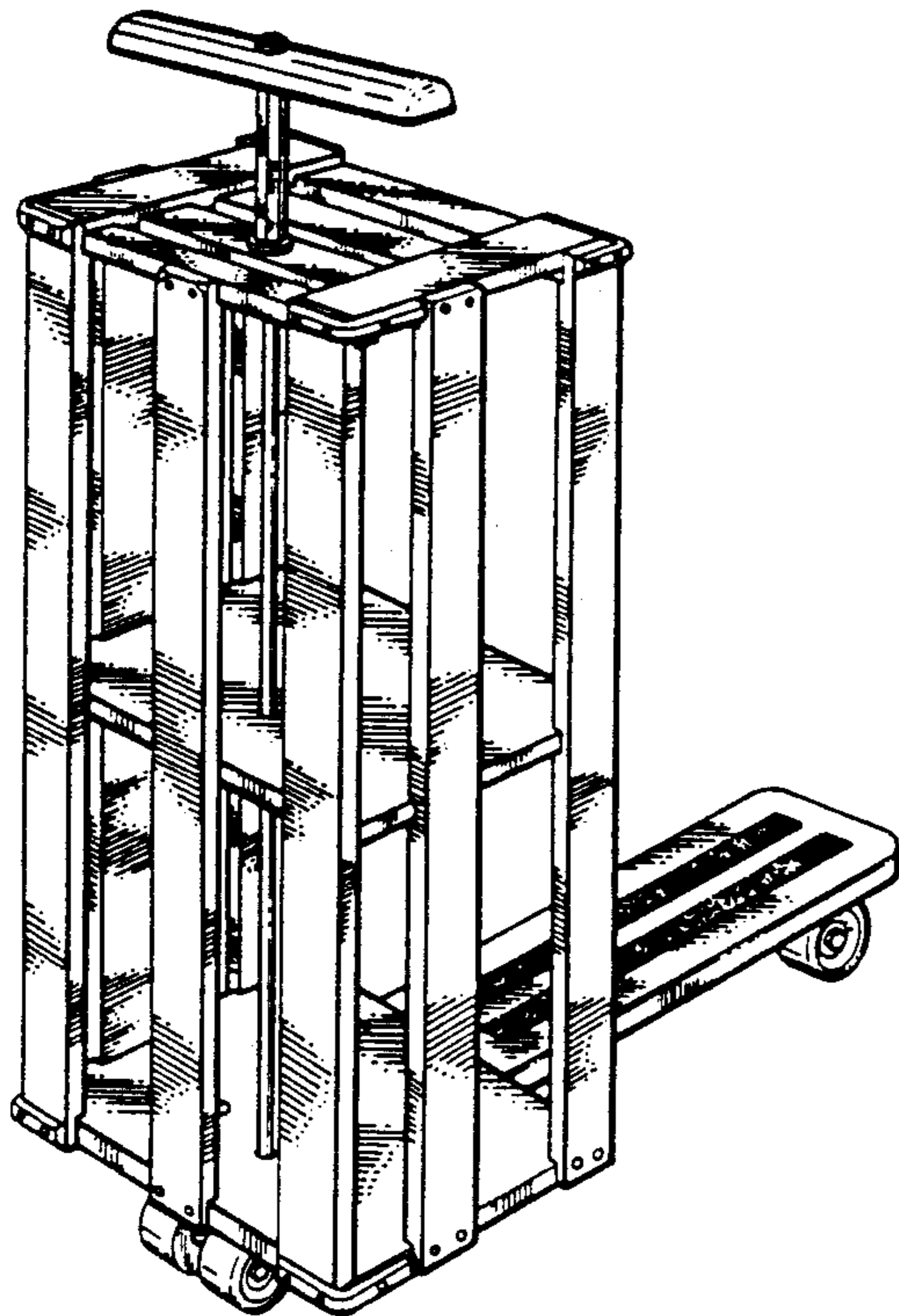

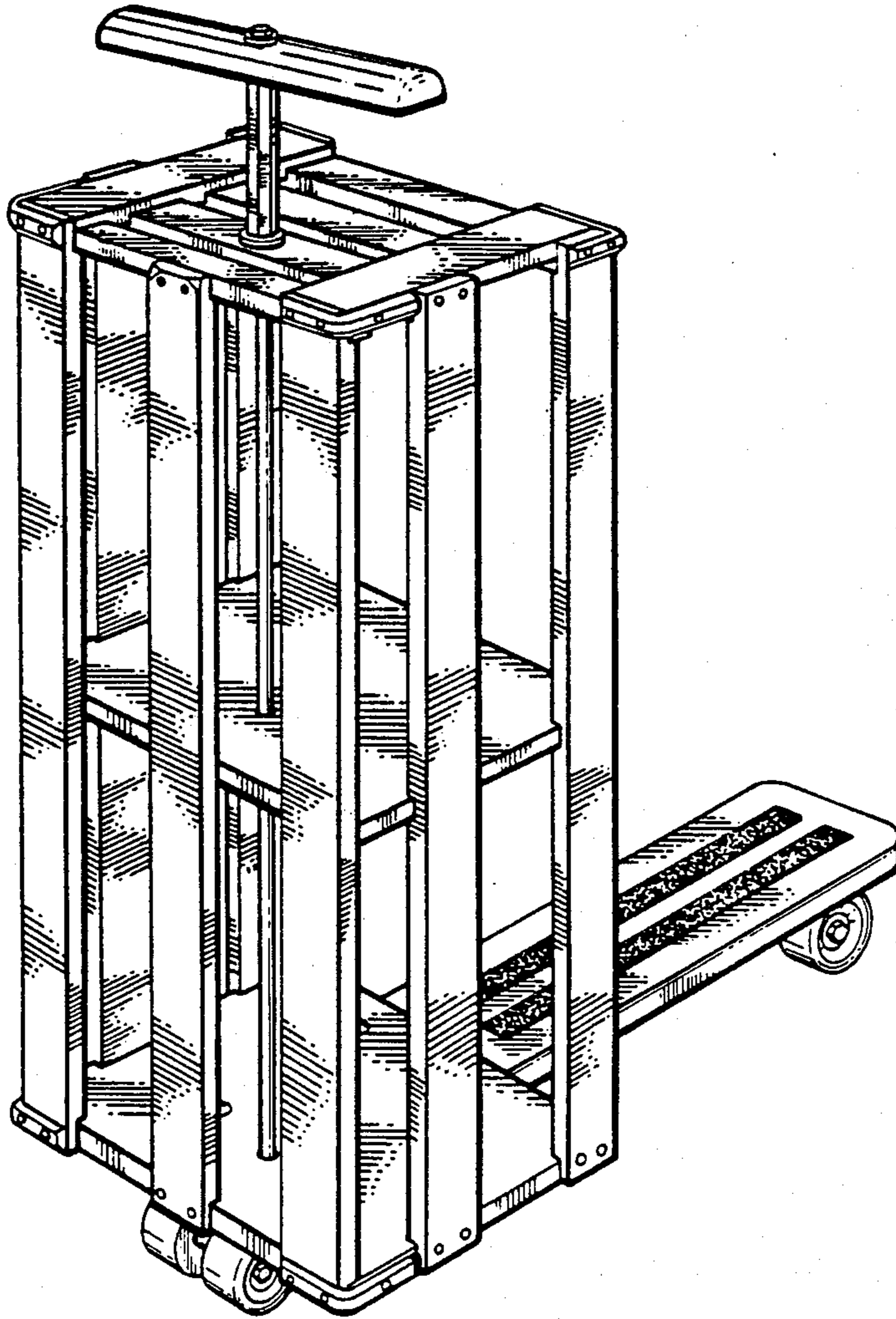

FIG. 1

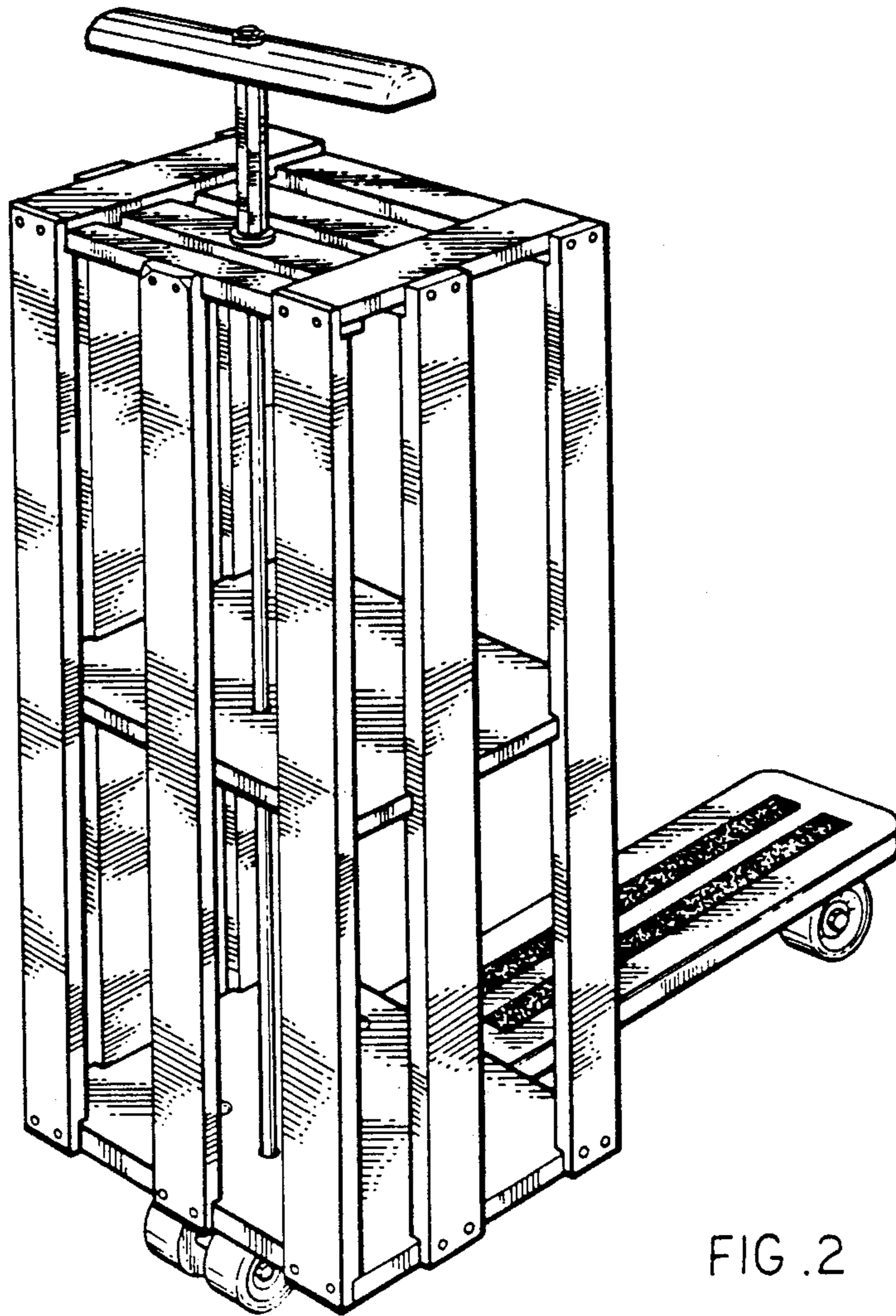

FIG. 2

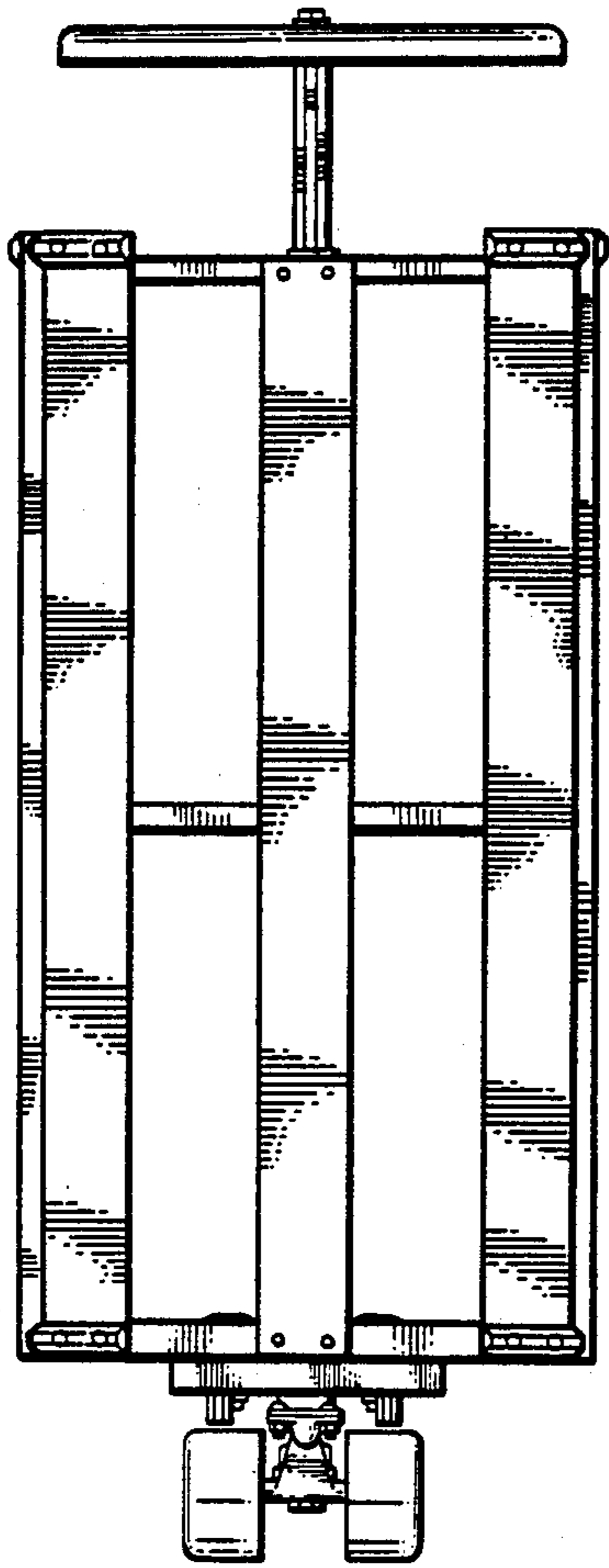

FIG. 3

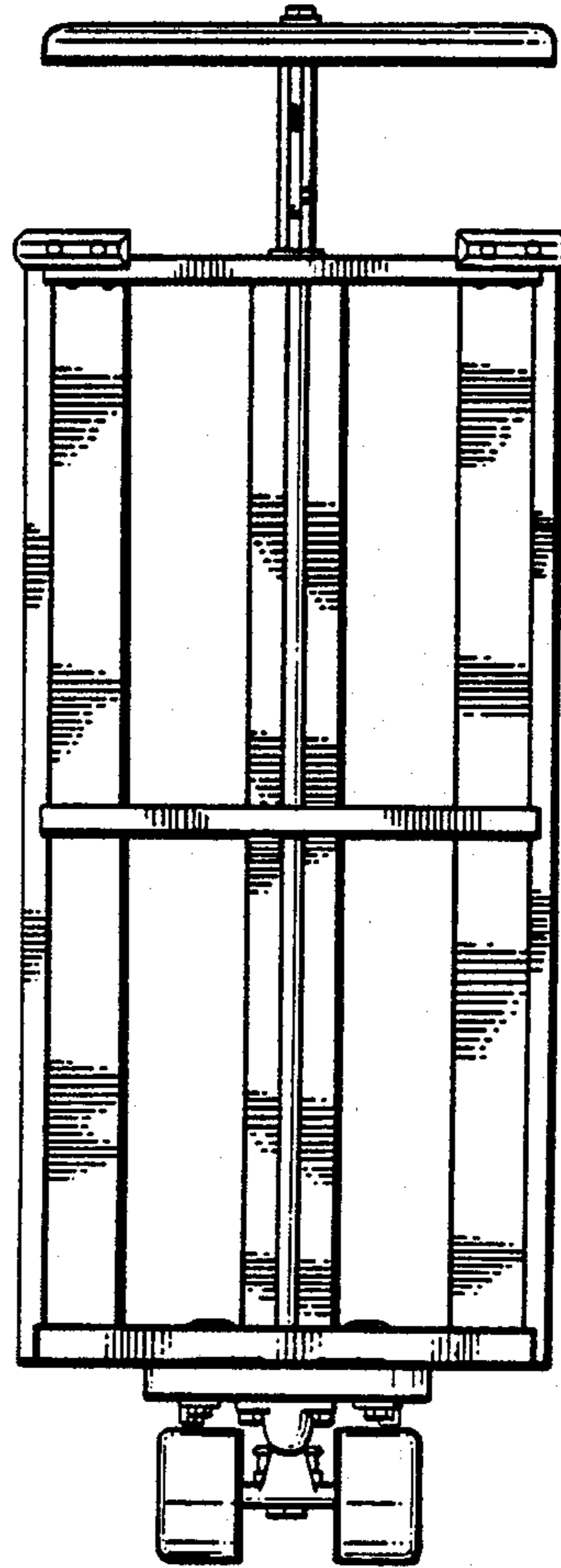

FIG. 4

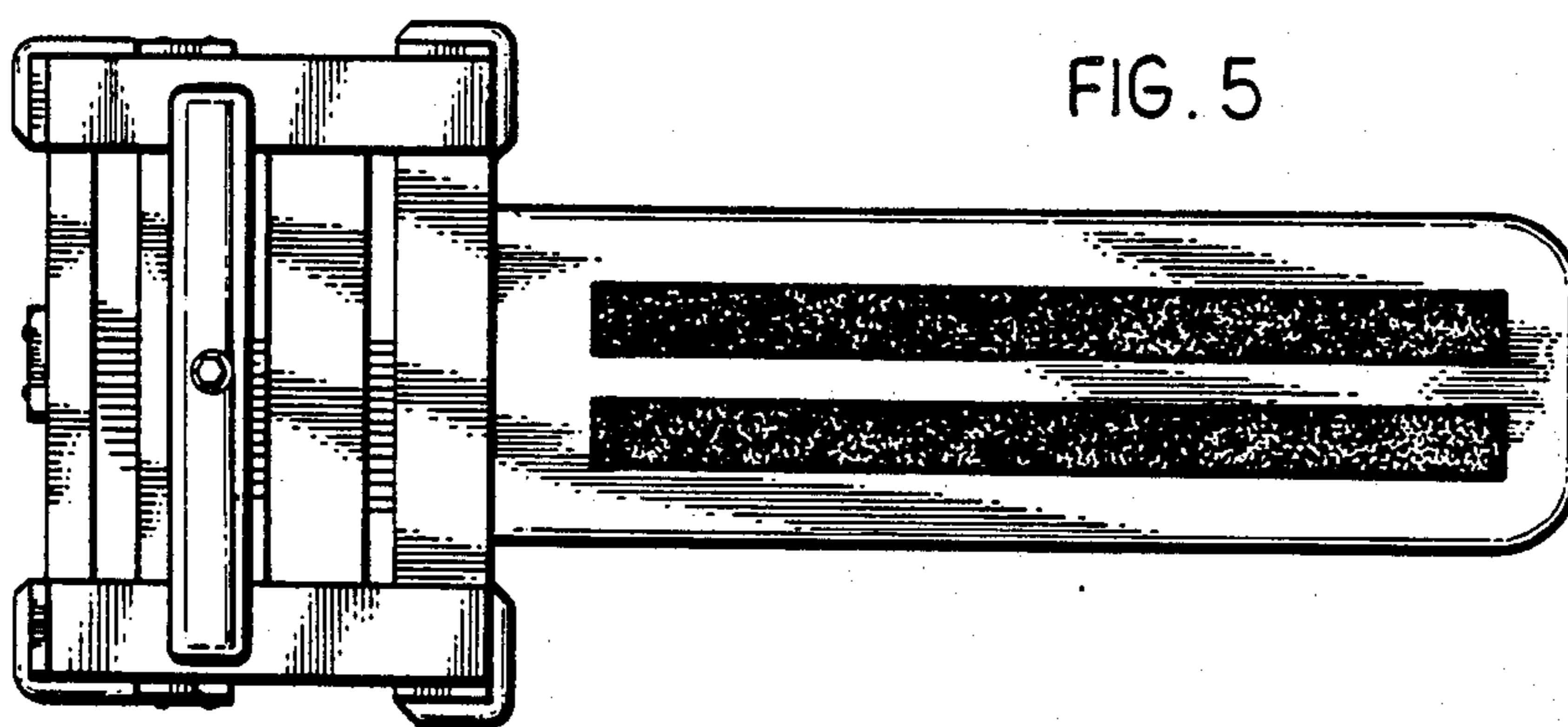

FIG. 5

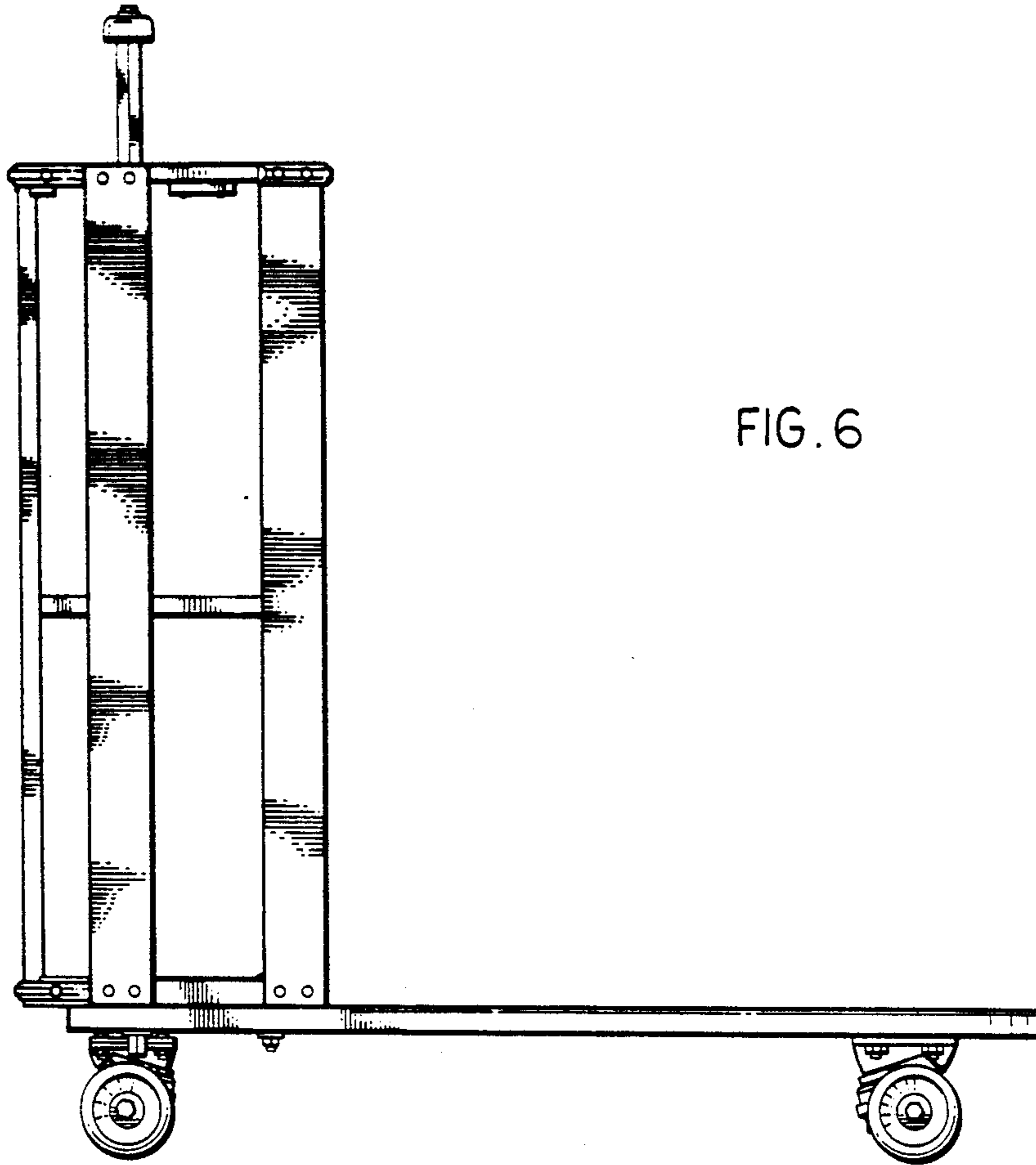

FIG. 6

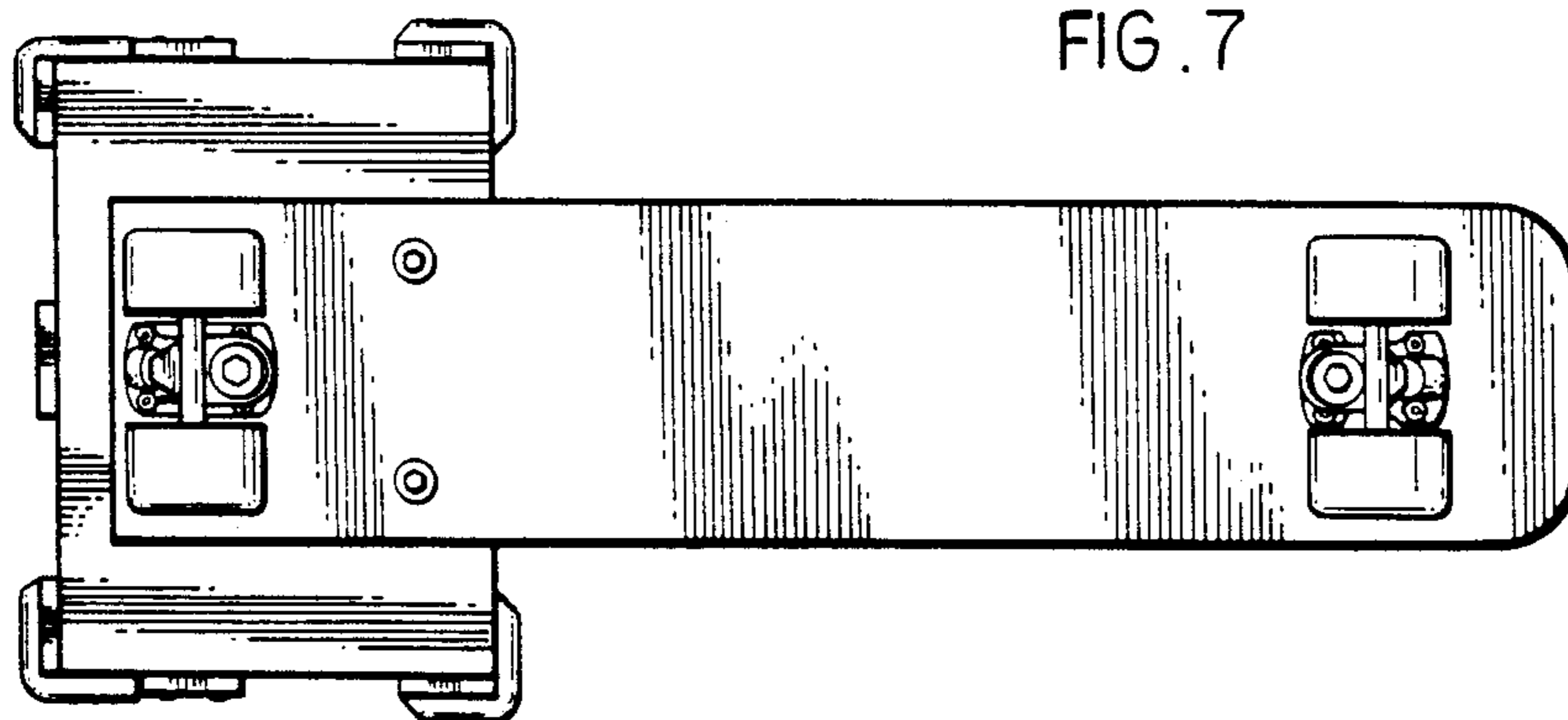

FIG. 7