

[54] COMBINED TILLER ARM AND CONTROL PANEL FOR AN OUTBOARD MOTOR

[75] Inventor: James R. Walsh, Oshkosh, Wis.

[73] Assignee: Brunswick Corporation, Skokie, Ill.

[**] Term: 14 Years

[21] Appl. No.: 812,228

[22] Filed: Dec. 23, 1985

[52] U.S. Cl. D15/4

[58] Field of Search D15/4; 114/144 R; 74/491-492, 480 B, 481, 523, 543; 440/6, 21, 32, 900

[56] References Cited

U.S. PATENT DOCUMENTS

- D. 276,811 12/1984 Wolfe D15/4
- 3,599,168 8/1971 Long 440/6 X
- 3,861,348 1/1975 Beierle 440/6
- 4,496,326 1/1985 Boda 114/144 R X

4,553,496 11/1985 Foresman 114/144 R

Primary Examiner—Wallace R. Burke
Assistant Examiner—Brian N. Vinson
Attorney, Agent, or Firm—O. T. Sessions

[57] CLAIM

The ornamental design for a combined tiller arm and control panel for an outboard motor, substantially as shown and described.

DESCRIPTION

FIG. 1 is a top, front and left side perspective view of a combined tiller arm and control panel for an outboard motor showing my new design;

FIG. 2 is a top plan view thereof;

FIG. 3 is an enlarged rear elevational view thereof;

FIG. 4 is a right side elevational view thereof;

FIG. 5 is a front elevational view thereof; and

FIG. 6 is a bottom plan view thereof.

The various connecting cables are shown broken-away in the views to indicate indeterminate length.

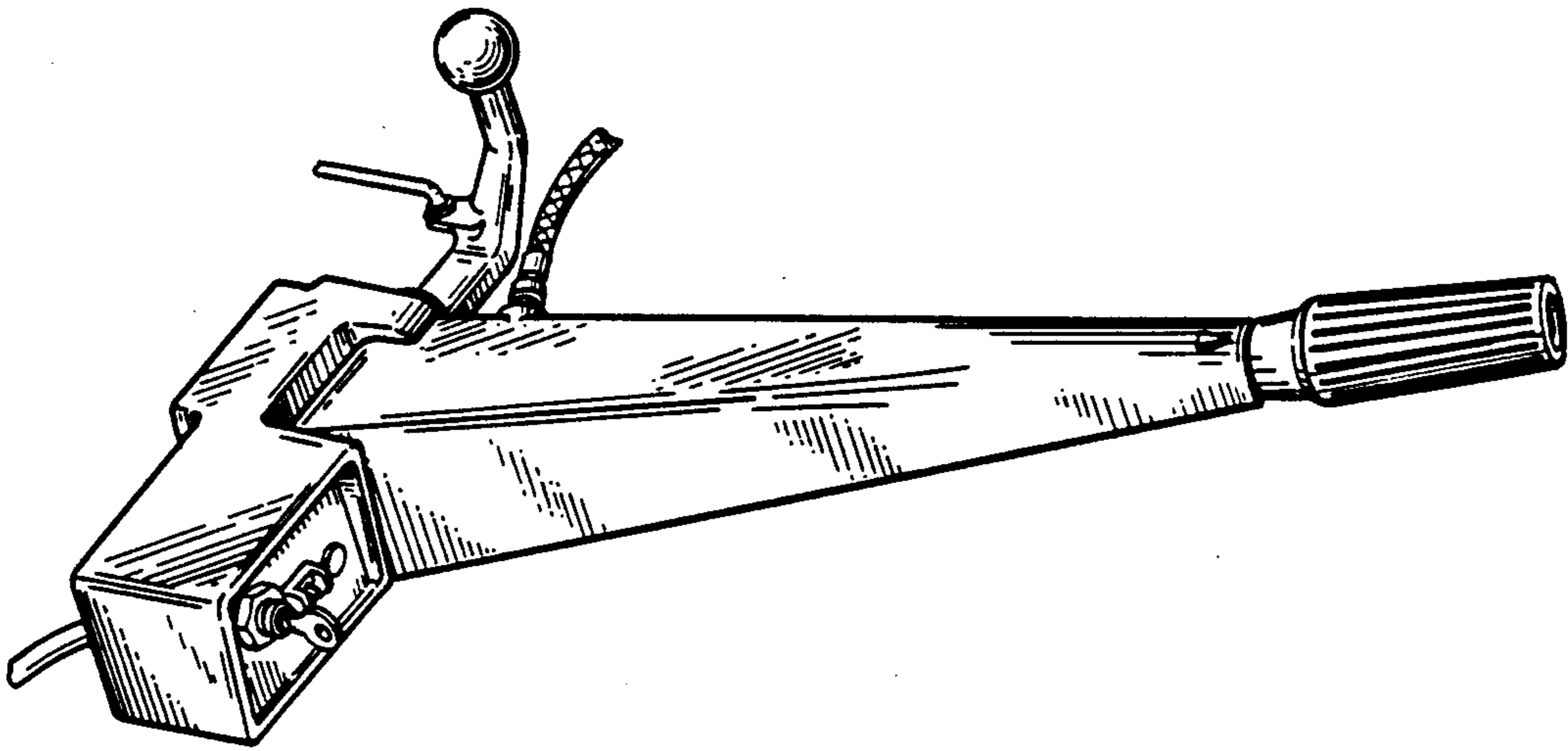

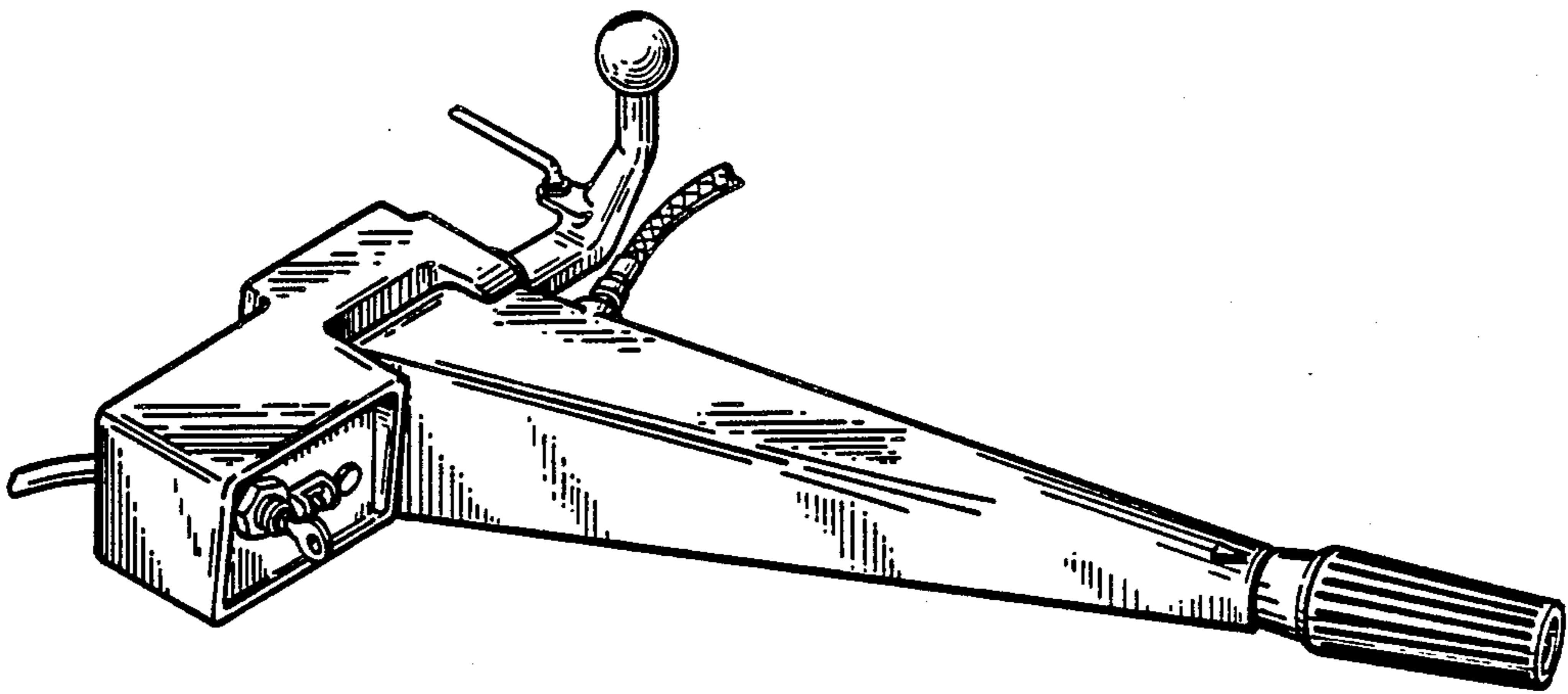

FIG 1

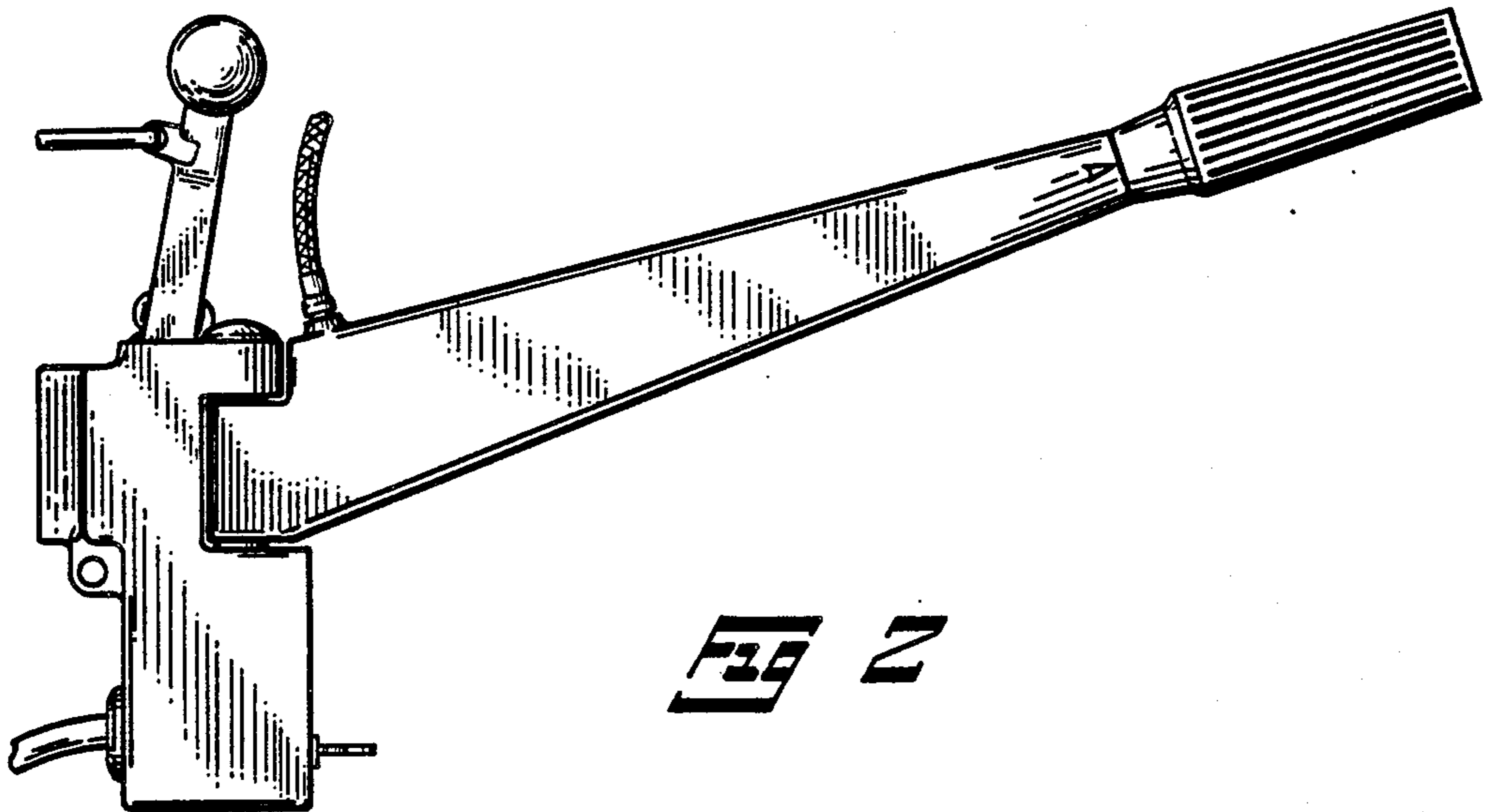

FIG 2

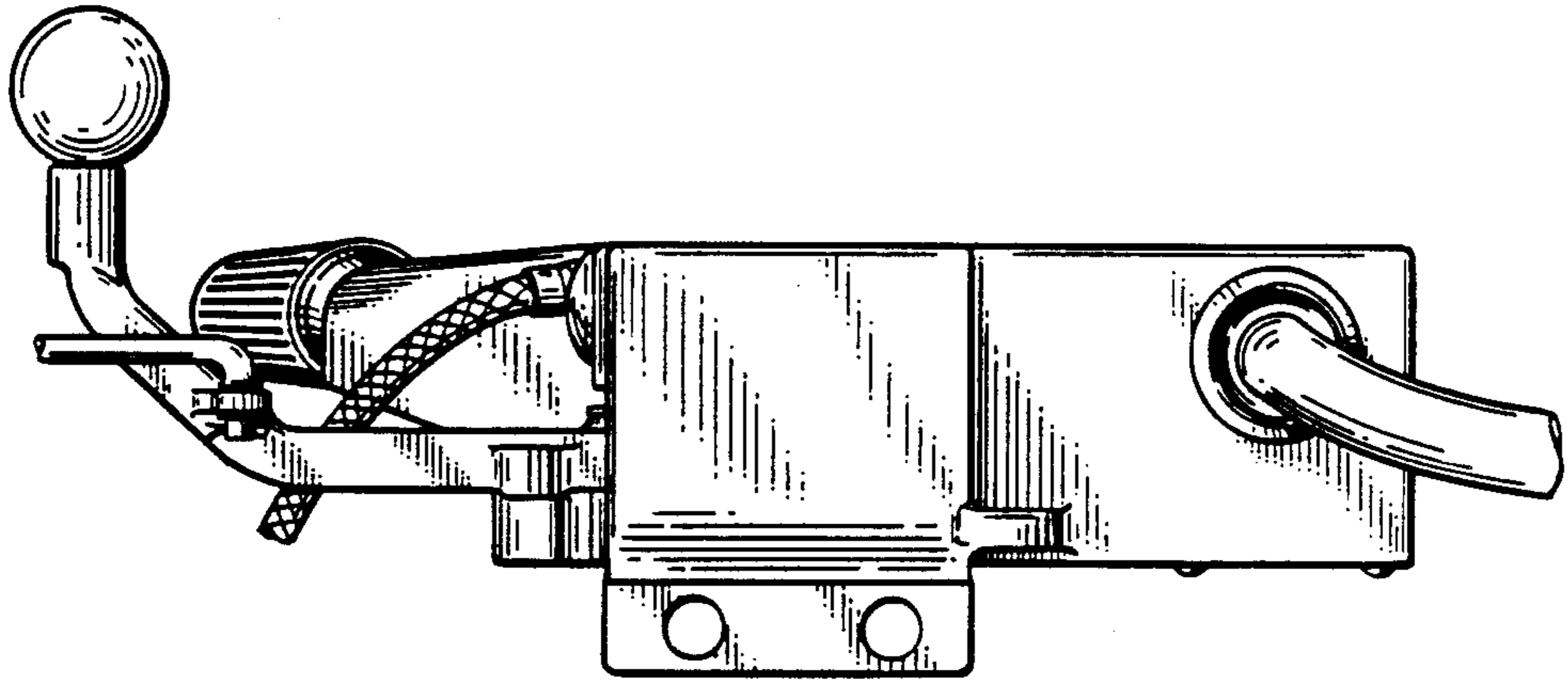

FIG 3

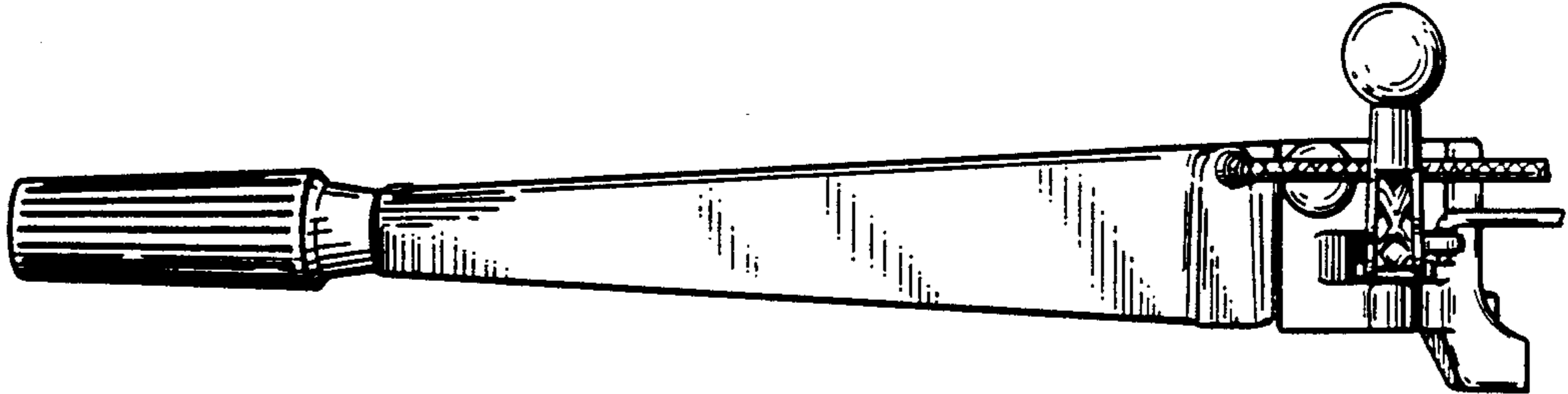

FIG 4



FIG 5

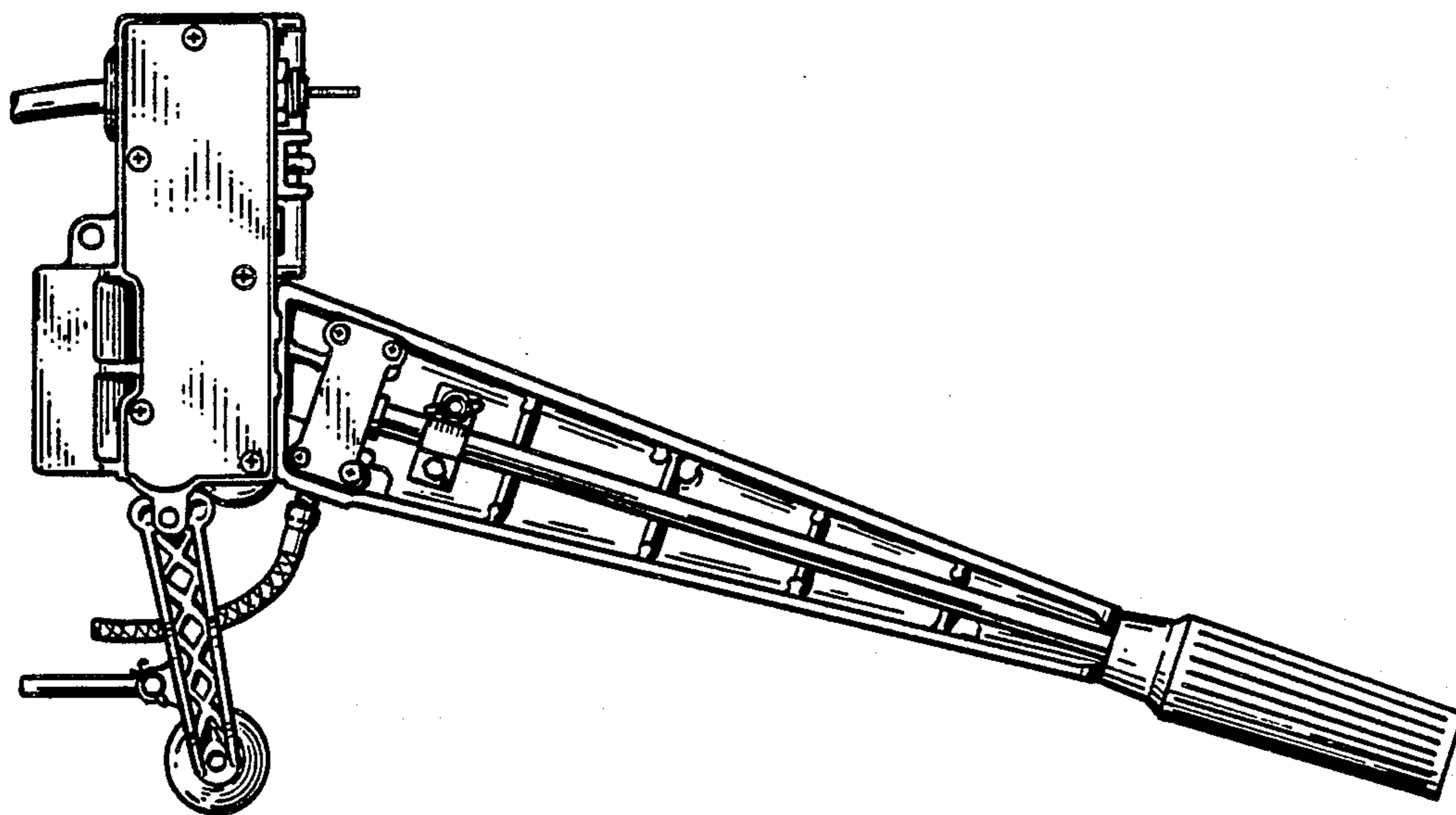

FIG 6