

[54] VEHICLE TIRE

[75] Inventor: Giuliano Ghilardi, Viale Marelli, Italy

[73] Assignee: Pirelli Coordinamento Pneumatici S.p.A., Italy

[\*] Notice: The portion of the term of this patent subsequent to Jun. 9, 2001 has been disclaimed.

[\*\*] Term: 14 Years

[21] Appl. No.: 765,532

[22] Filed: Aug. 14, 1985

[30] Foreign Application Priority Data

Feb. 15, 1985 [IT] Italy ..... 20807/85[U]

[52] U.S. Cl. .... D12/147

[58] Field of Search ..... D12/141-143, D12/146-151; 152/209 R, 209 D

[56]

References Cited

U.S. PATENT DOCUMENTS

- D. 252,871 9/1979 Gill et al. .... D12/147
- D. 290,247 6/1987 Ghilardi ..... D12/147

Primary Examiner—James M. Gandy  
Attorney, Agent, or Firm—Stevens, Davis, Miller & Mosher

[57]

CLAIM

The ornamental design for a vehicle tire, as shown and described.

DESCRIPTION

FIG. 1 is a perspective view of a vehicle tire showing my new design, it being understood that the tread pattern is repeated uniformly throughout the circumference of the tire as shown schematically by solid lines, the opposite side being the same as that shown; FIG. 2 is a front elevation view thereof; and FIG. 3 is a side elevation view thereof.

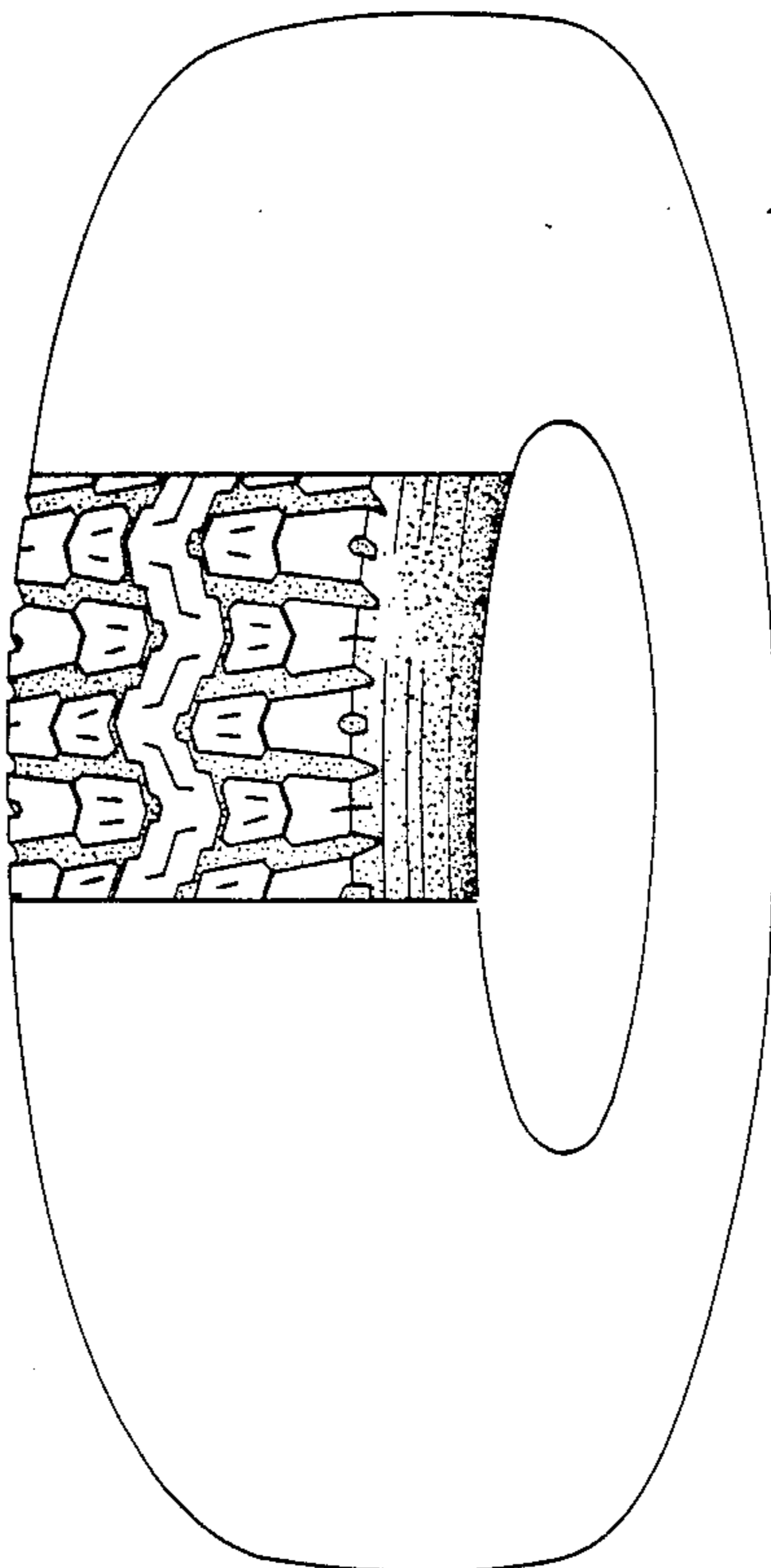

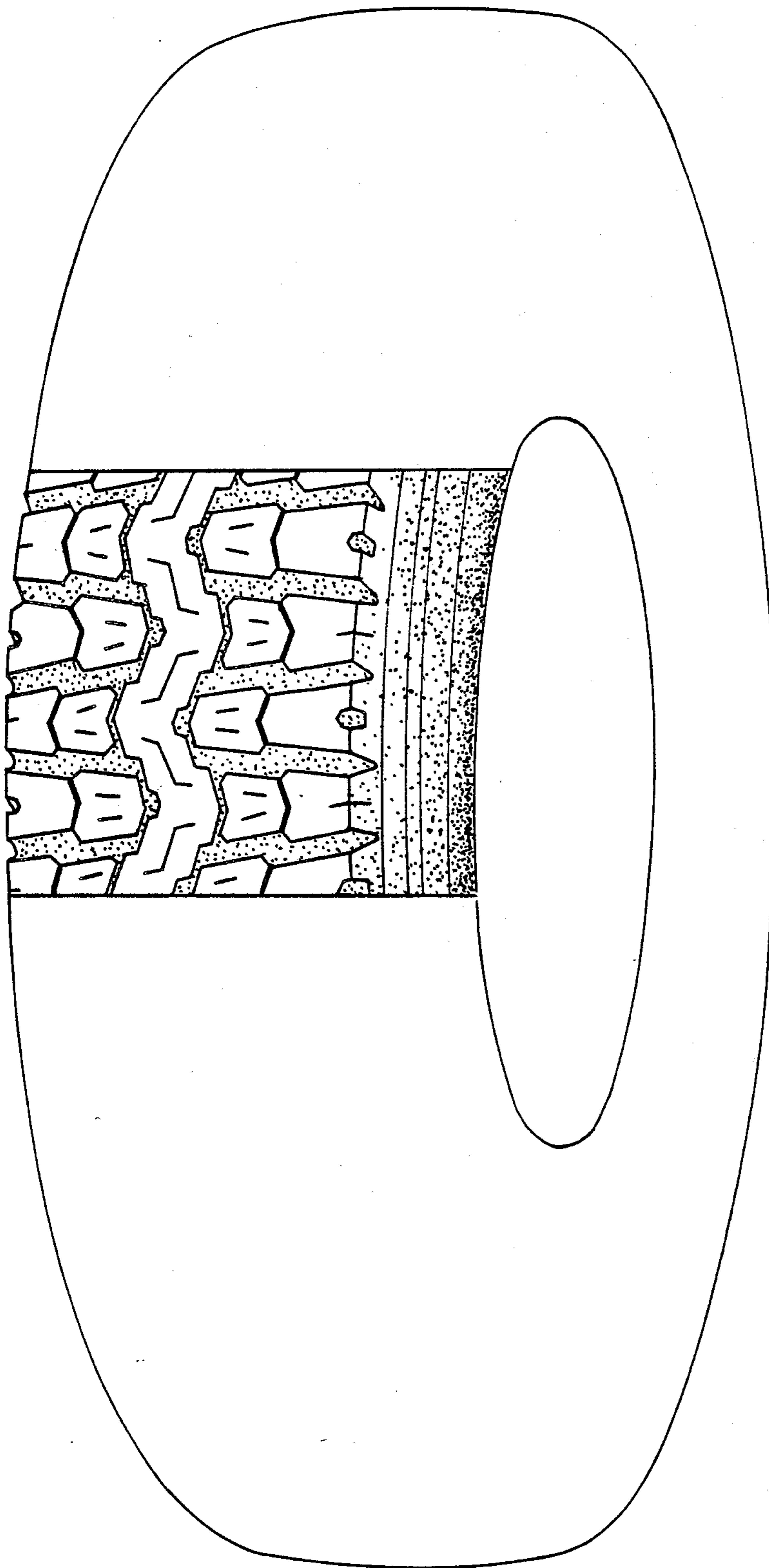

FIG 1

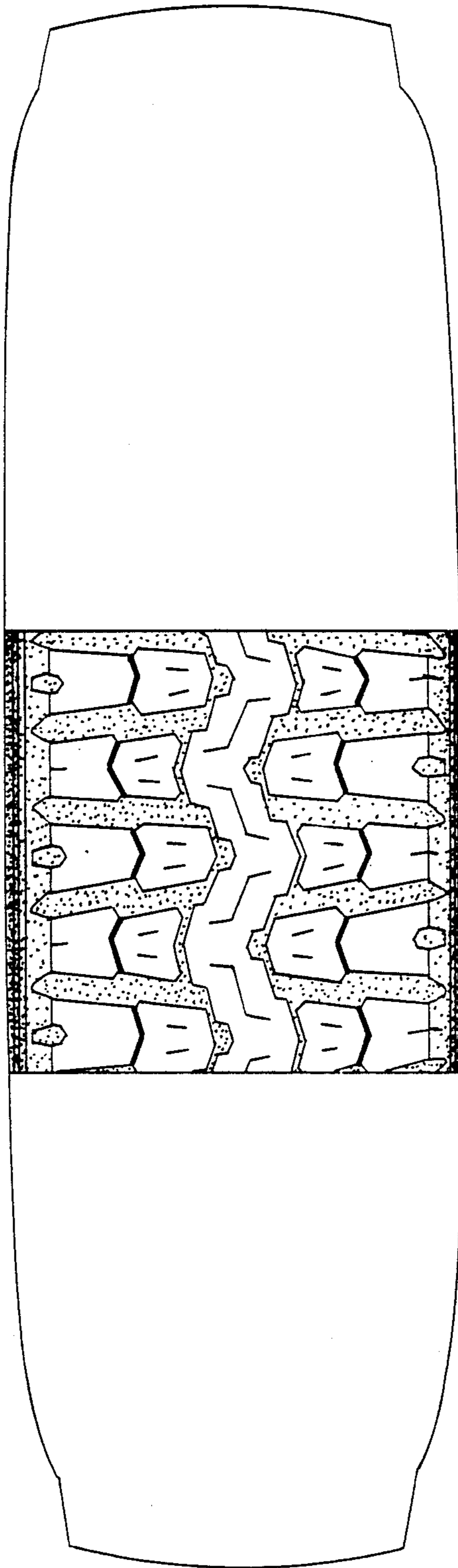

FIG 2

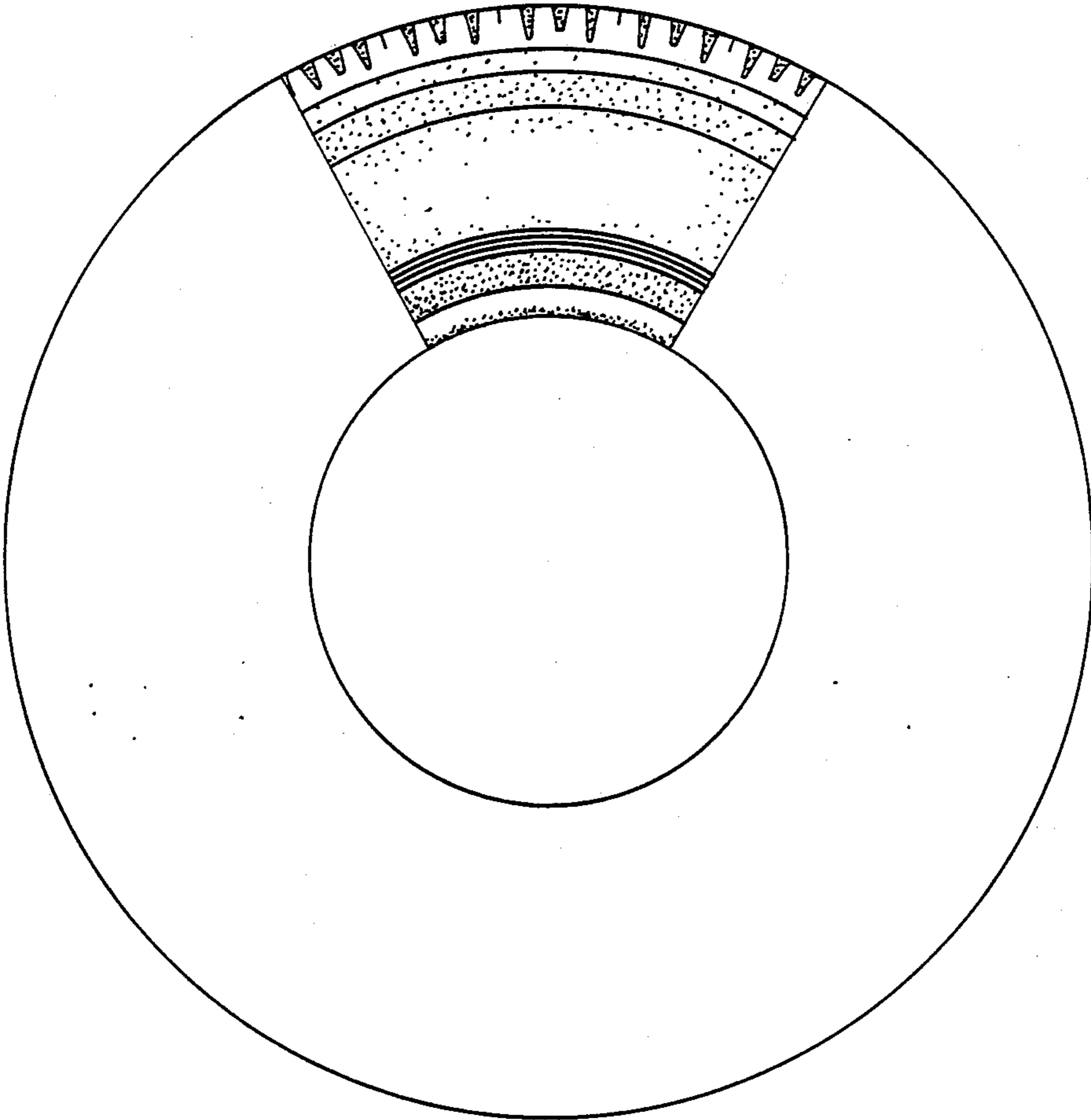

FIG 3