

[54] TOY VEHICULAR CONSTRUCTION PIECE

[75] Inventor: Flemming H. Olsen, Espergaerde, Denmark

[73] Assignee: Interlego A.G., Baar, Switzerland

[**] Term: 14 Years

[21] Appl. No.: 935,692

[22] Filed: Nov. 26, 1986

[52] U.S. Cl. D21/108

[58] Field of Search D21/108, 71, 73, 128, D21/140; 446/71, 72, 88, 93, 94, 95, 465, 469, 470, 471, 128

4,631,040 12/1986 Shiraishi 446/124
4,684,355 8/1987 Orakawa et al. 446/95

Primary Examiner—Charles A. Rademaker
Attorney, Agent, or Firm—Kane, Dalsimer, Sullivan, Kurucz, Levy, Eisele and Richard

[57] CLAIM

The ornamental design for a toy vehicular construction piece, as shown and described.

DESCRIPTION

FIG. 1 is a top perspective view of the toy vehicular construction piece showing my new design, FIG. 2 is a bottom perspective view thereof, FIG. 3 is a front elevational view thereof FIG. 4 is a side elevational view thereof, the side opposite being substantially a mirror image; FIG. 5 is a top plan view thereof, FIG. 6 is a bottom plan view thereof, and FIG. 7 is a rear elevational view thereof.

[56] References Cited

U.S. PATENT DOCUMENTS

- D. 282,090 1/1986 Takahashi D21/108
- D. 287,519 12/1986 Takahashi D21/108
- D. 291,100 7/1987 Knudsen D21/108

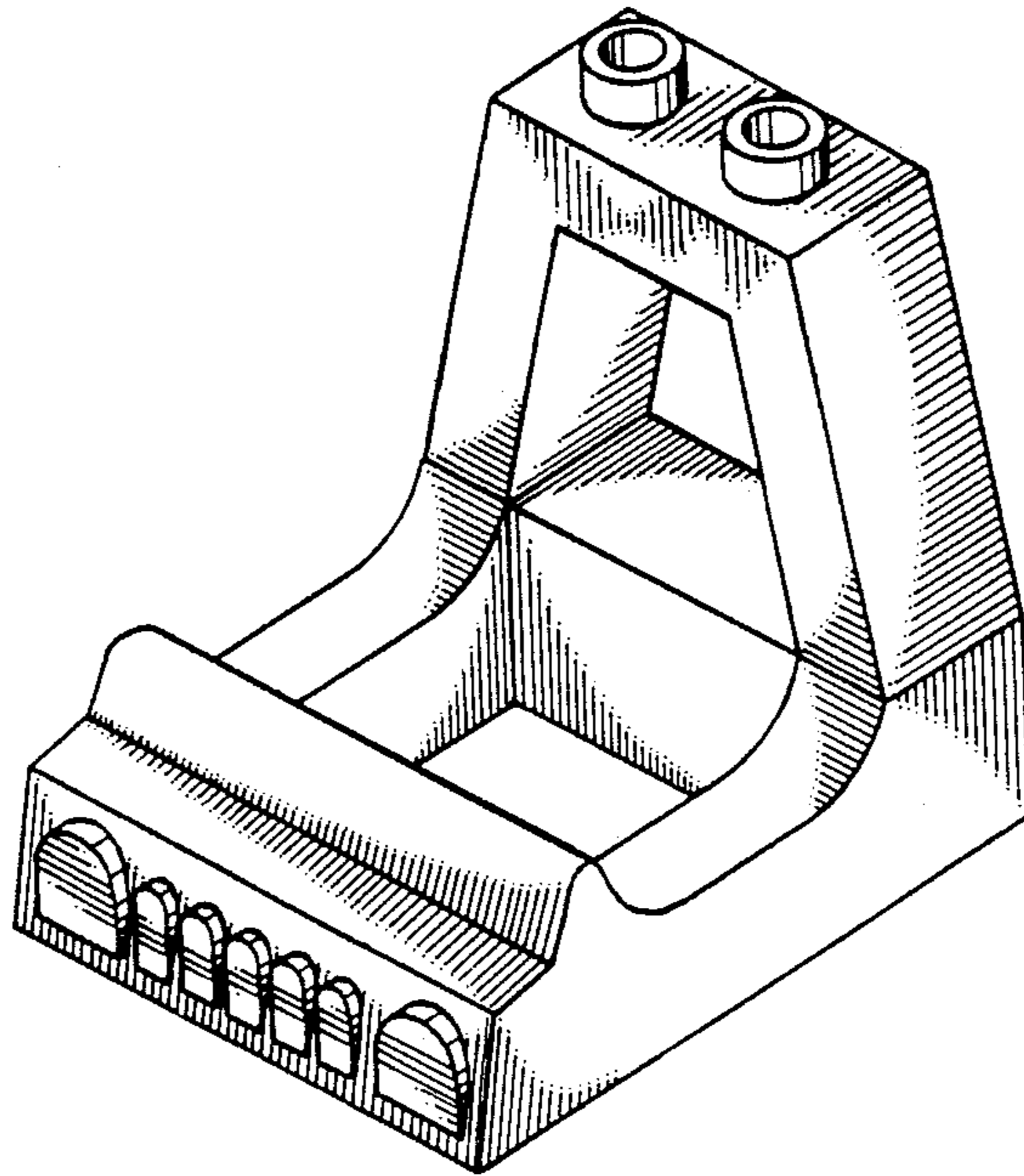

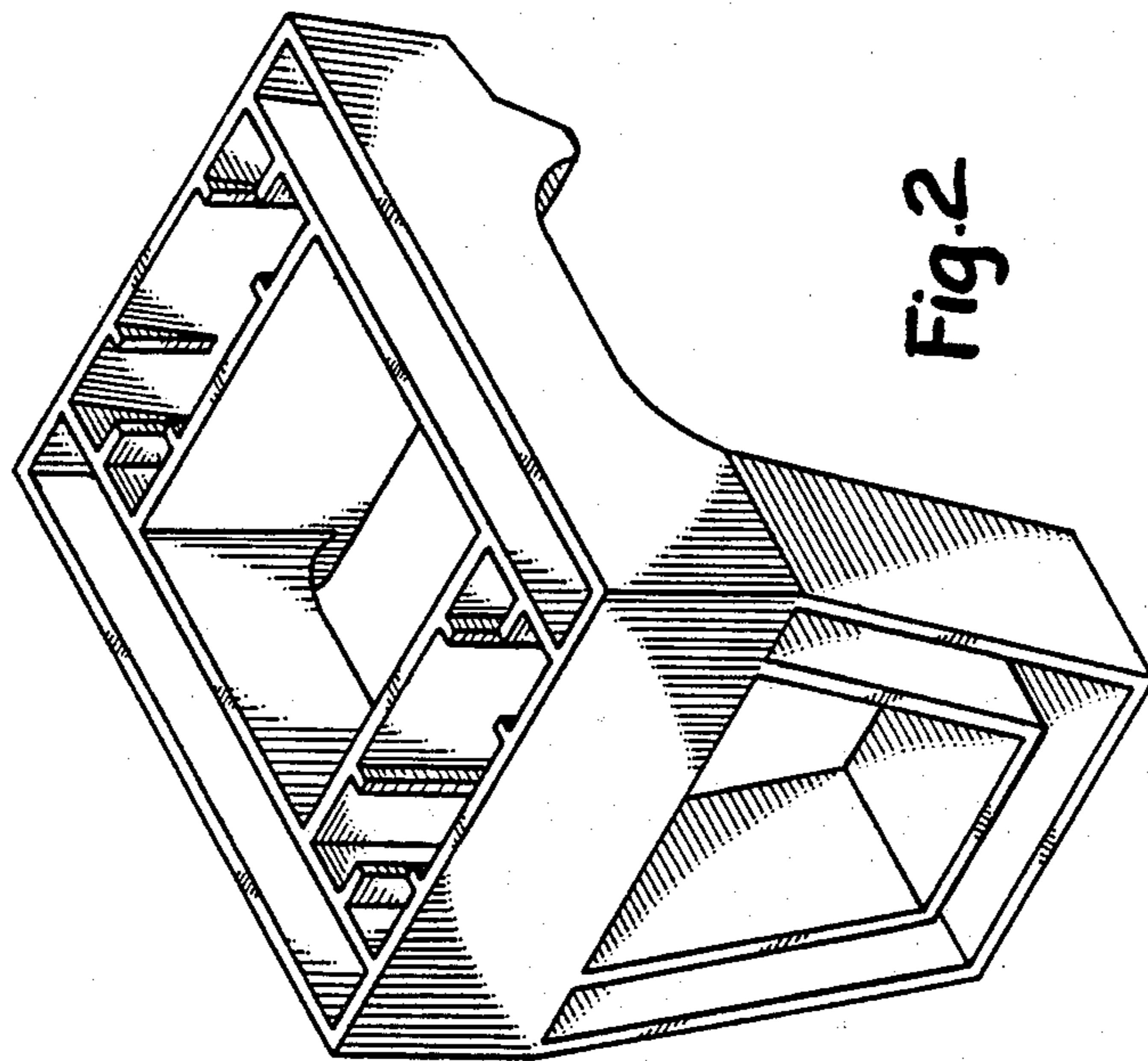

Fig. 2

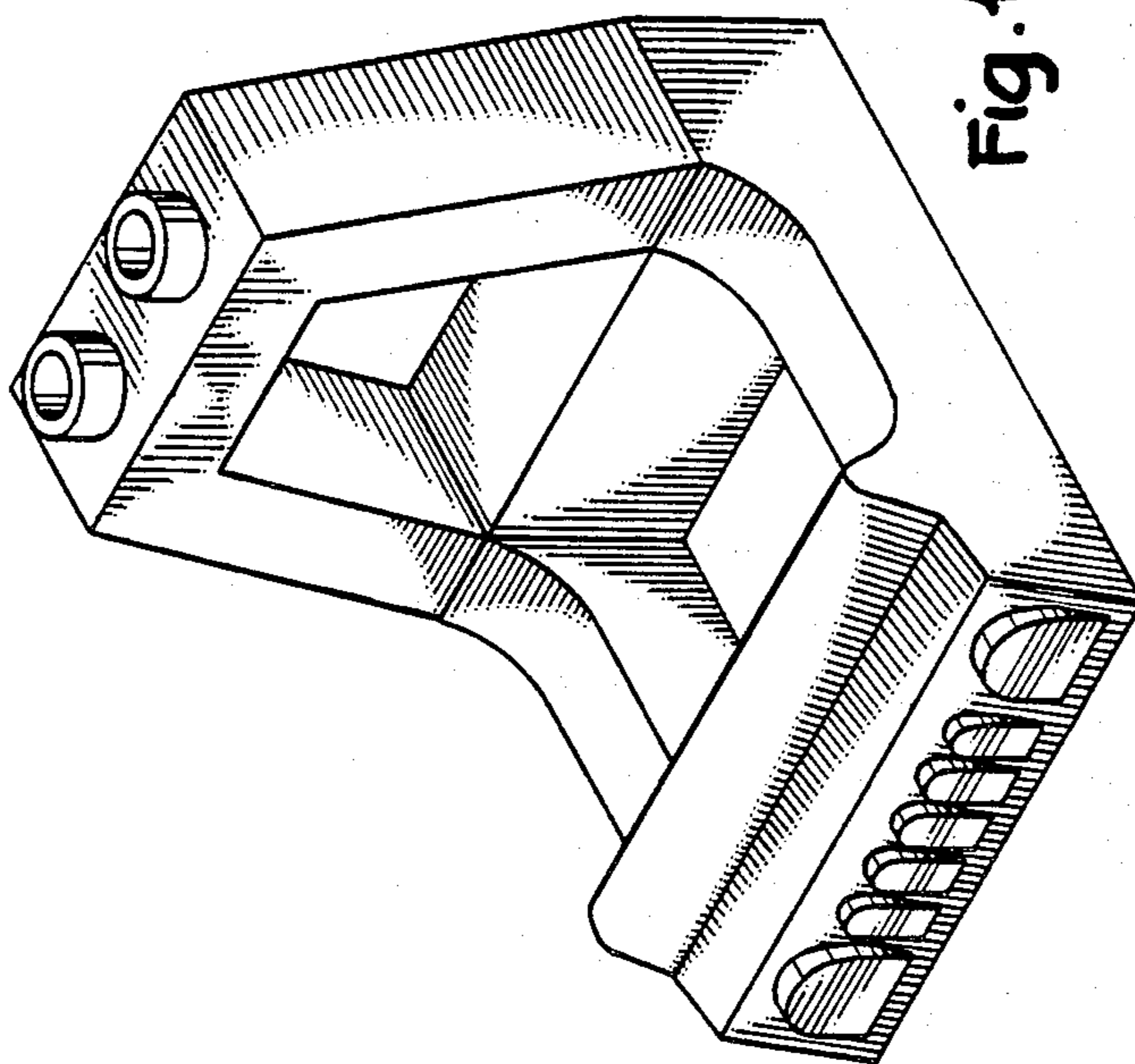

Fig. 1

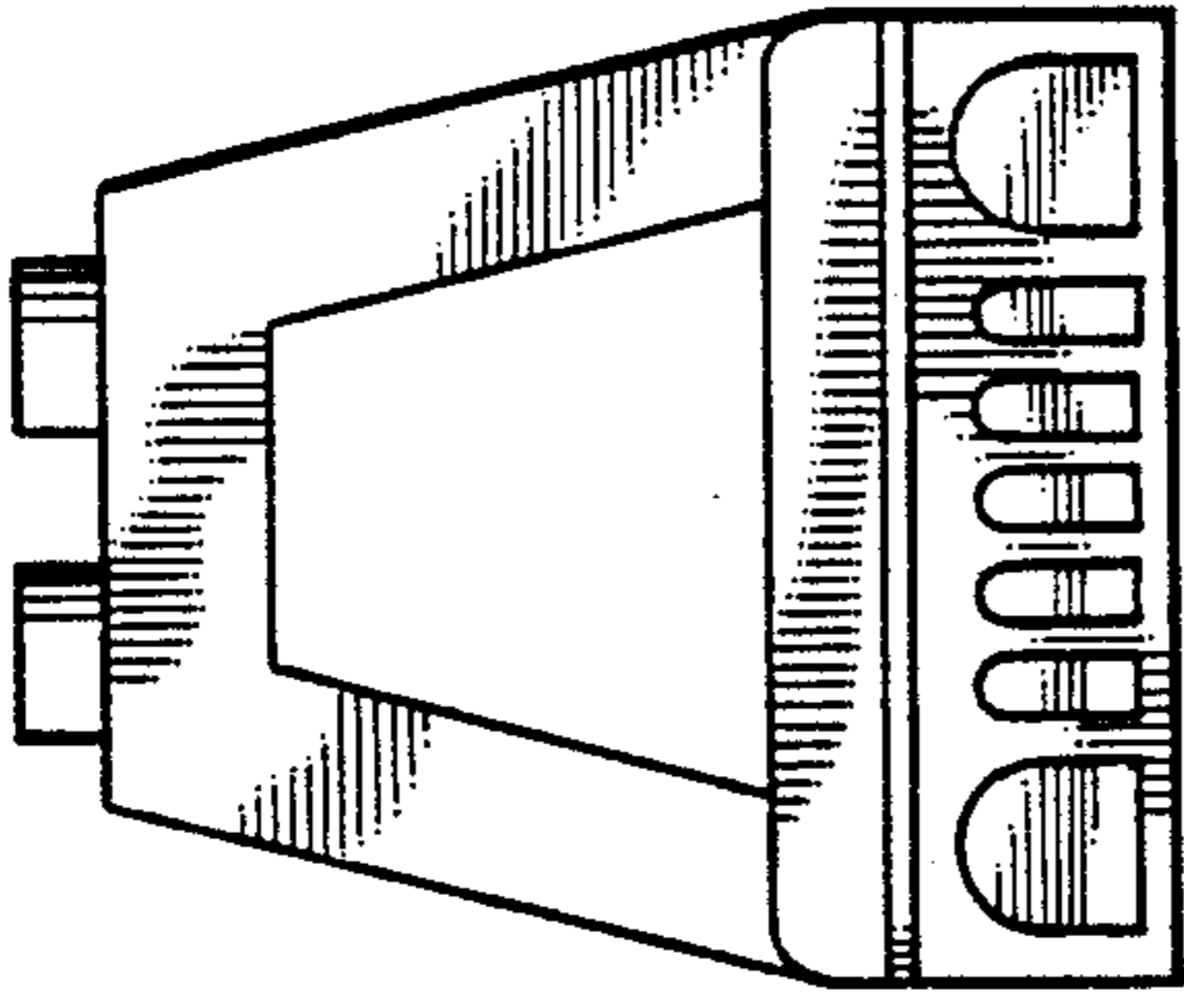

Fig. 3

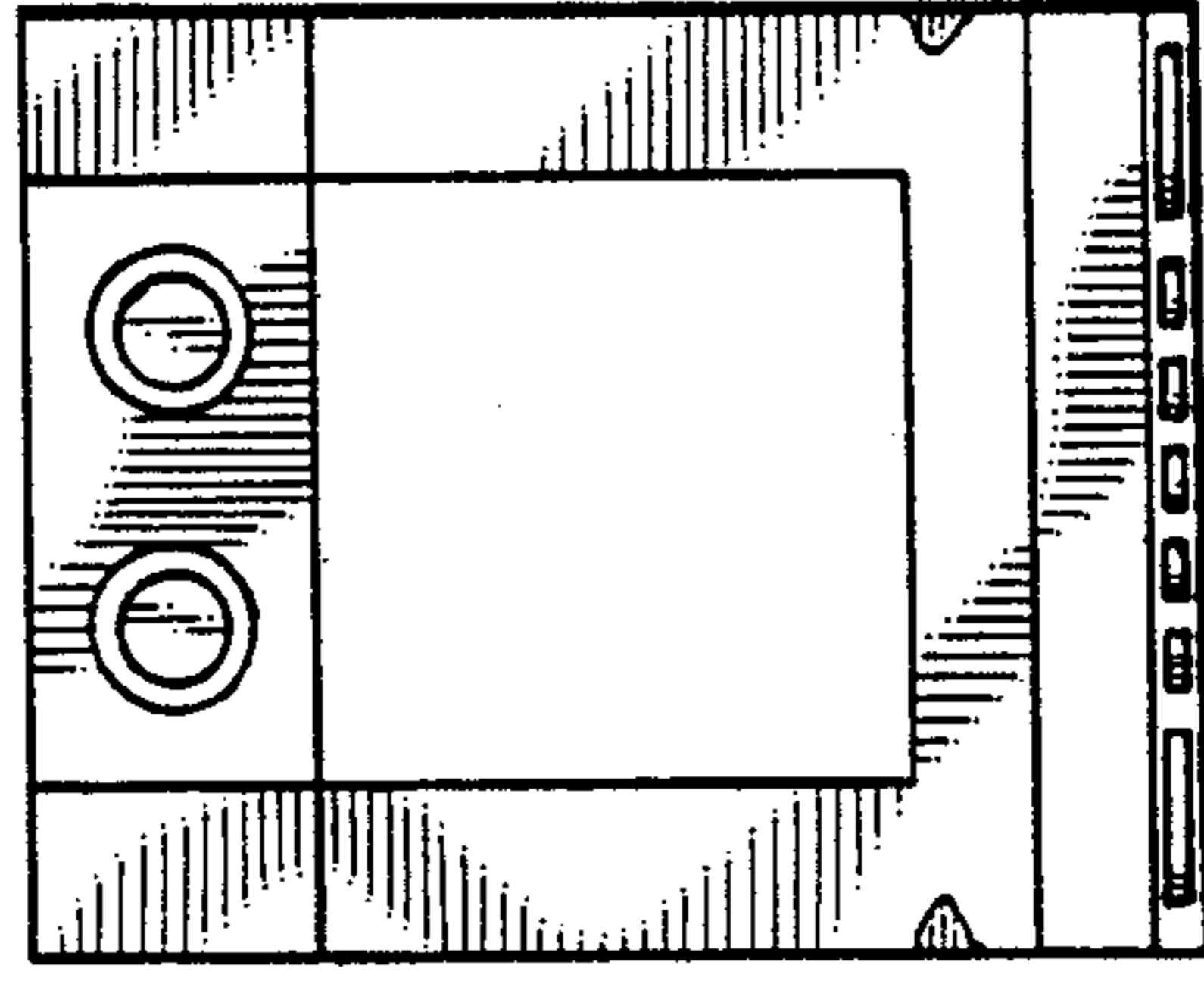

Fig. 5

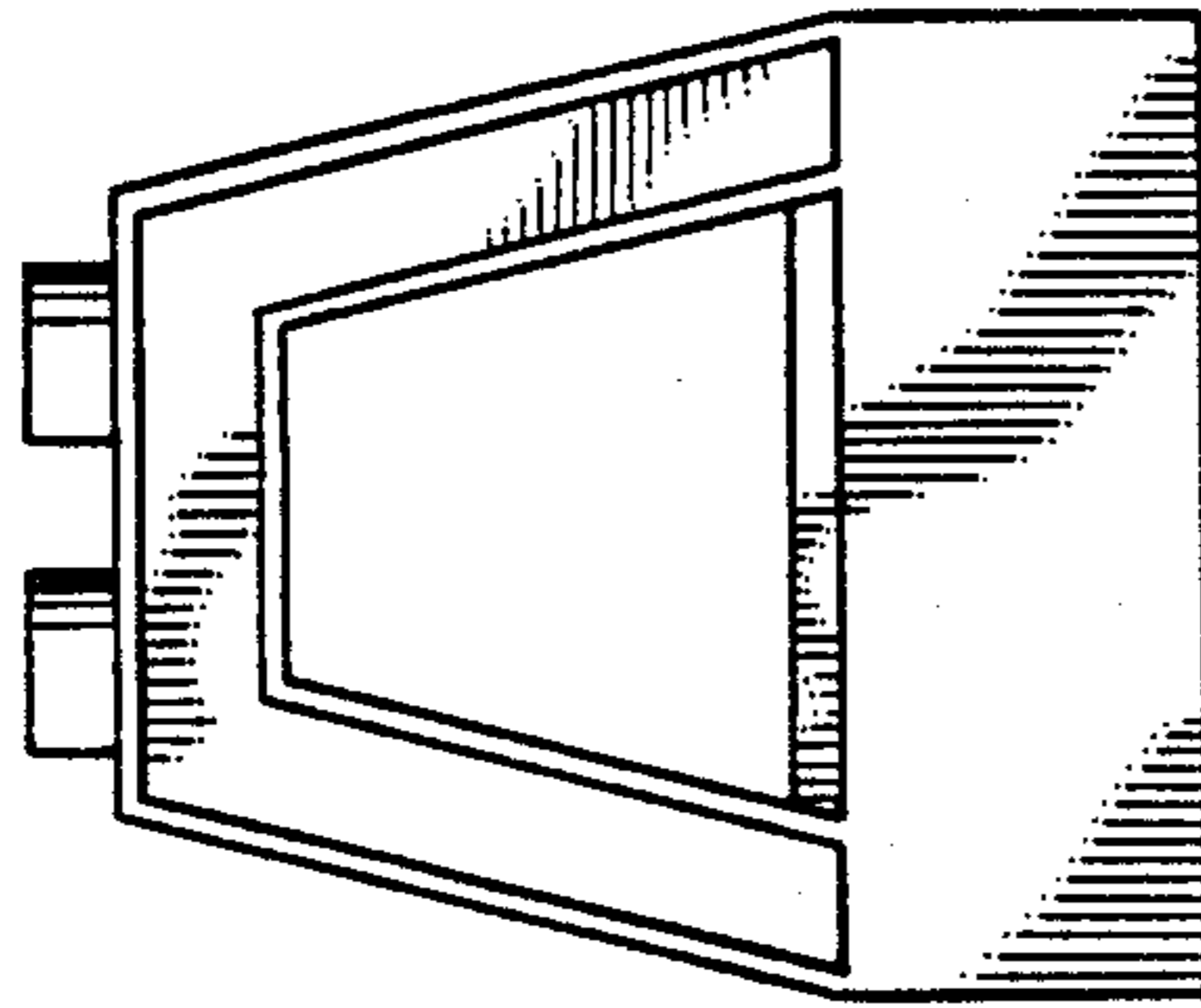

Fig. 7

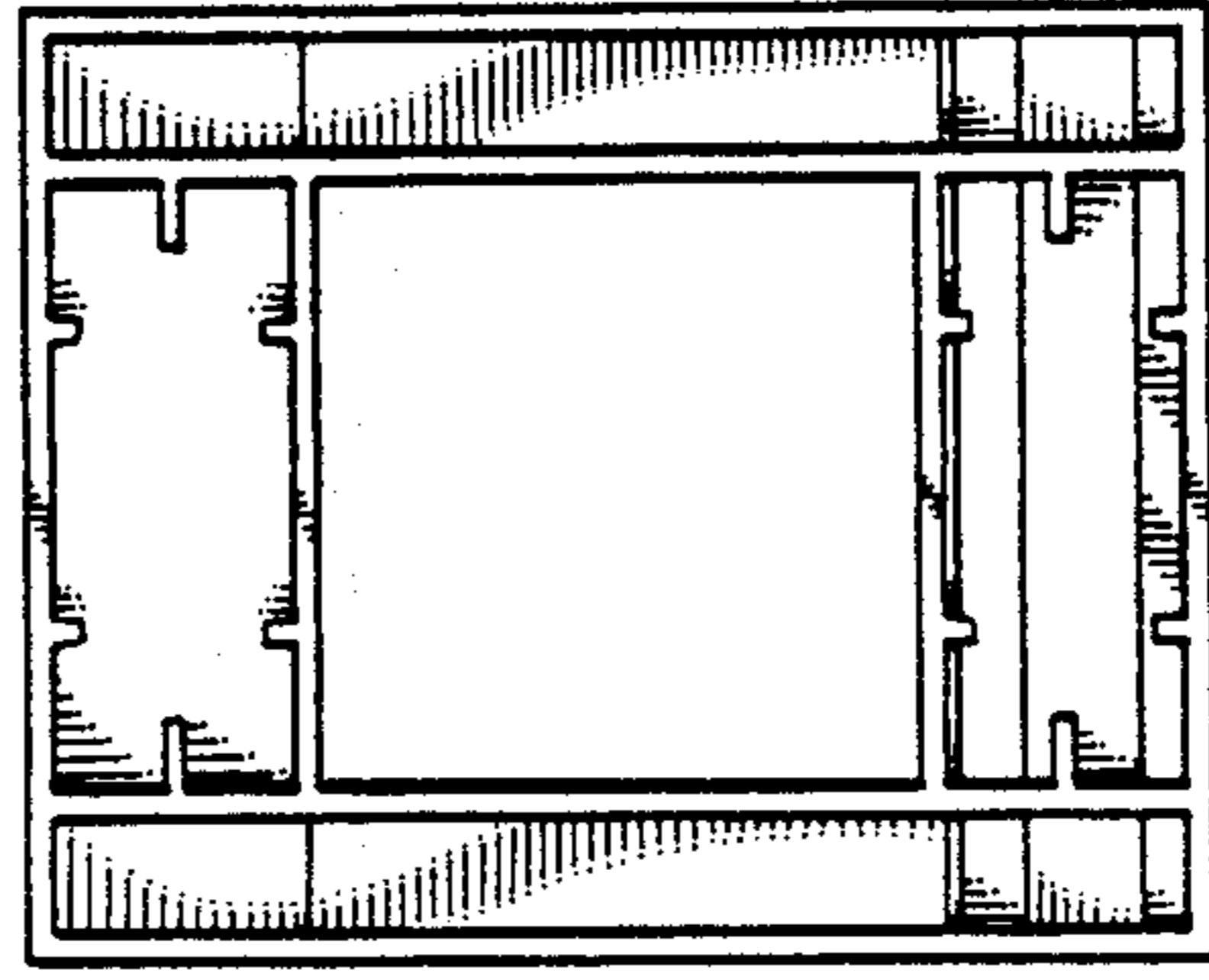

Fig. 6

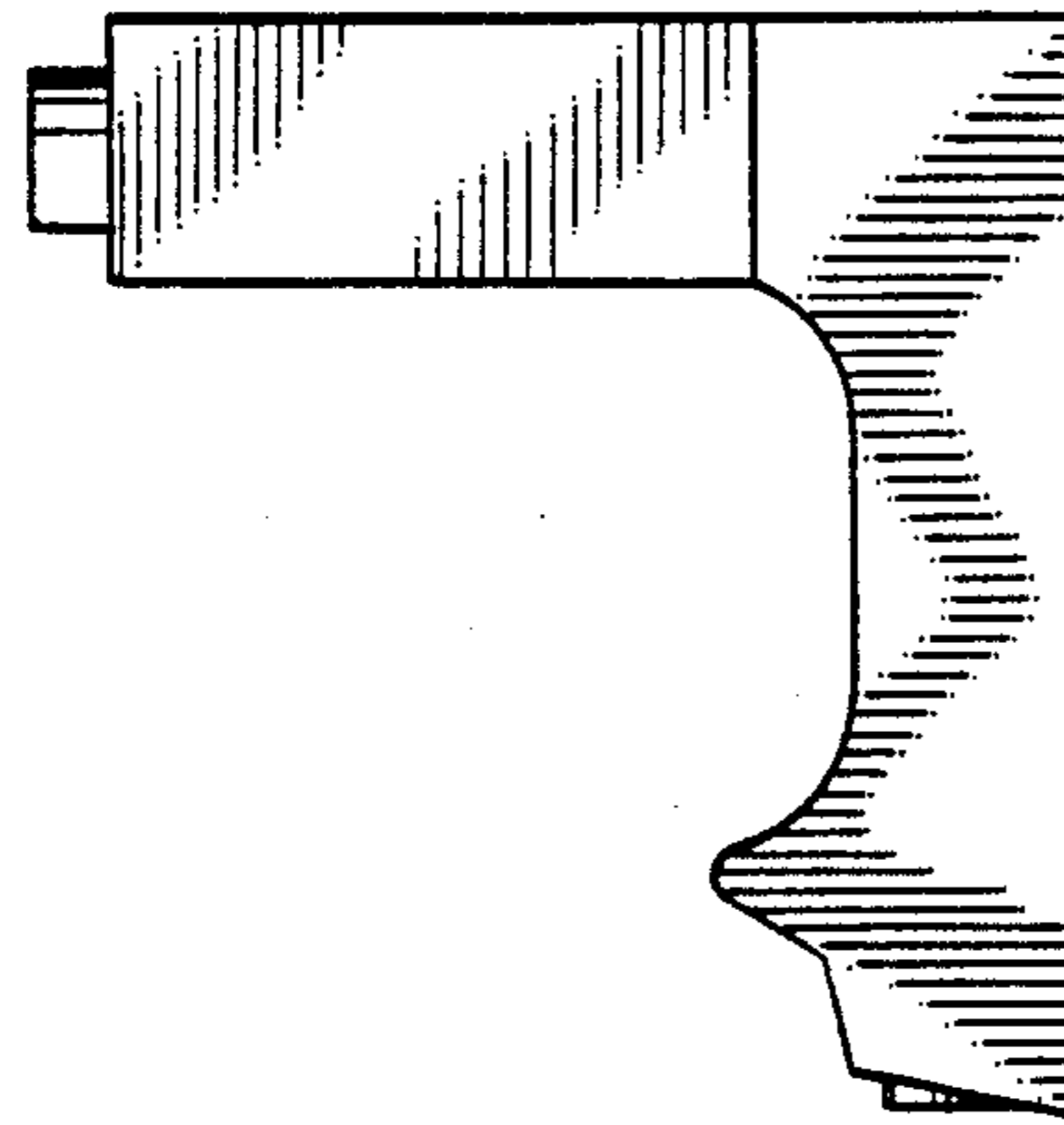

Fig. 4