

[54] AUTOMOTIVE REAR DECK BEZEL

[76] Inventor: George B. Kobel, 3039 Single Peak, San Antonio, Tex. 78261

[\*\*] Term: 14 Years

[21] Appl. No.: 804,171

[22] Filed: Dec. 3, 1985

[52] U.S. Cl. .... D12/196

[58] Field of Search ..... D12/156, 196; 296/76, 296/195, 196, 197, 201

[56] References Cited

U.S. PATENT DOCUMENTS

3,781,059 12/1973 Davis ..... 296/76

OTHER PUBLICATIONS

Hot Rod, 7/73, p. 121, Rear Deck of Corvette including "sliver" windows, top of page.  
Motor Trend, 2/85, p. 88, rear upper window section of Porsche 928S, bottom of page.

Primary Examiner—James M. Gandy  
Attorney, Agent, or Firm—John C. Stahl

[57] CLAIM

The ornamental design for an automotive rear deck bezel, as shown.

DESCRIPTION

FIG. 1 is a side elevational view of an automotive rear deck bezel, showing my new design.  
FIG. 2 is a top plan view thereof;  
FIG. 3 is a rear elevational view thereof; and  
FIG. 4 is an enlarged cross-sectional view thereof taken along line 4—4 in FIG. 2.

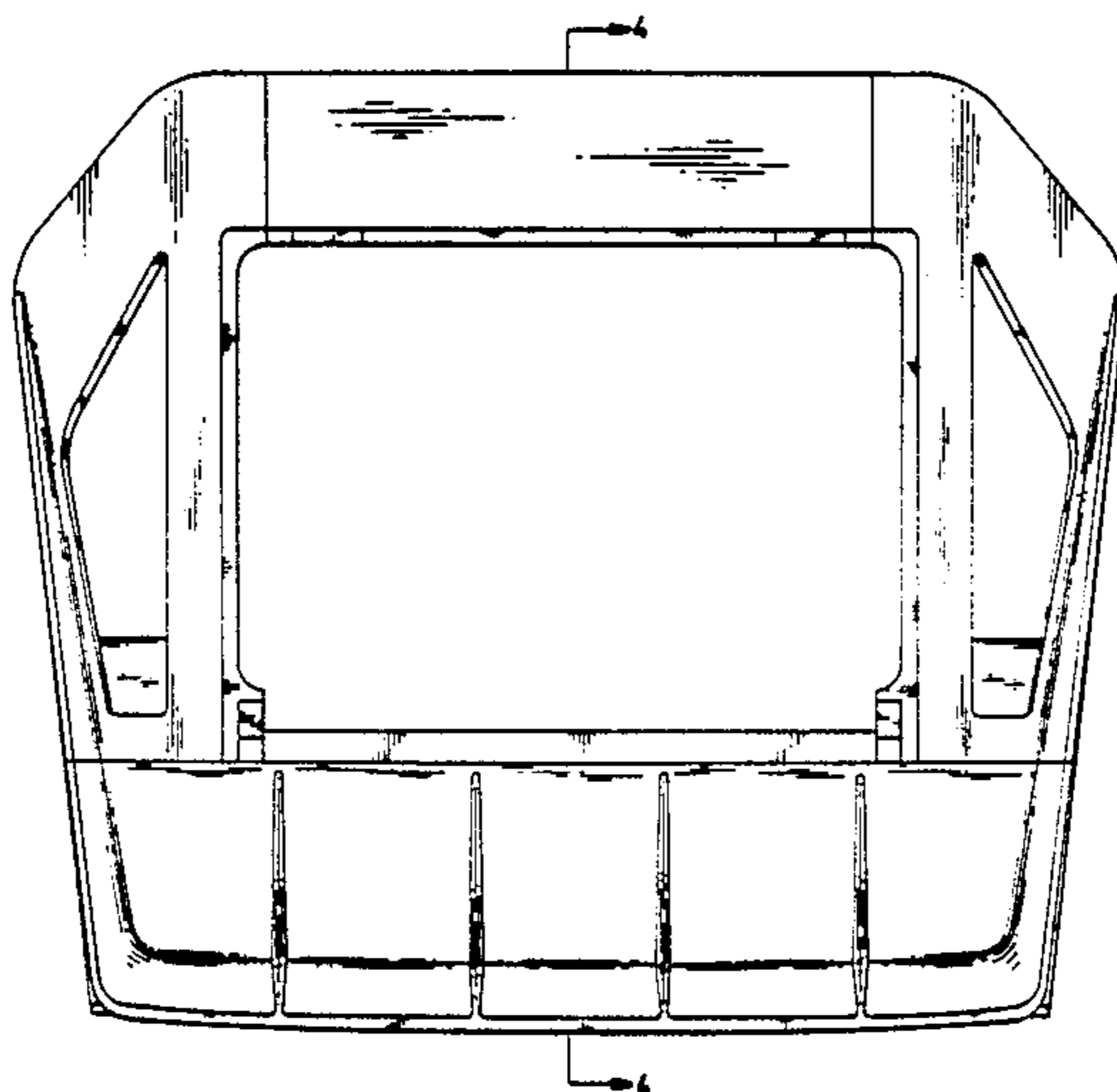
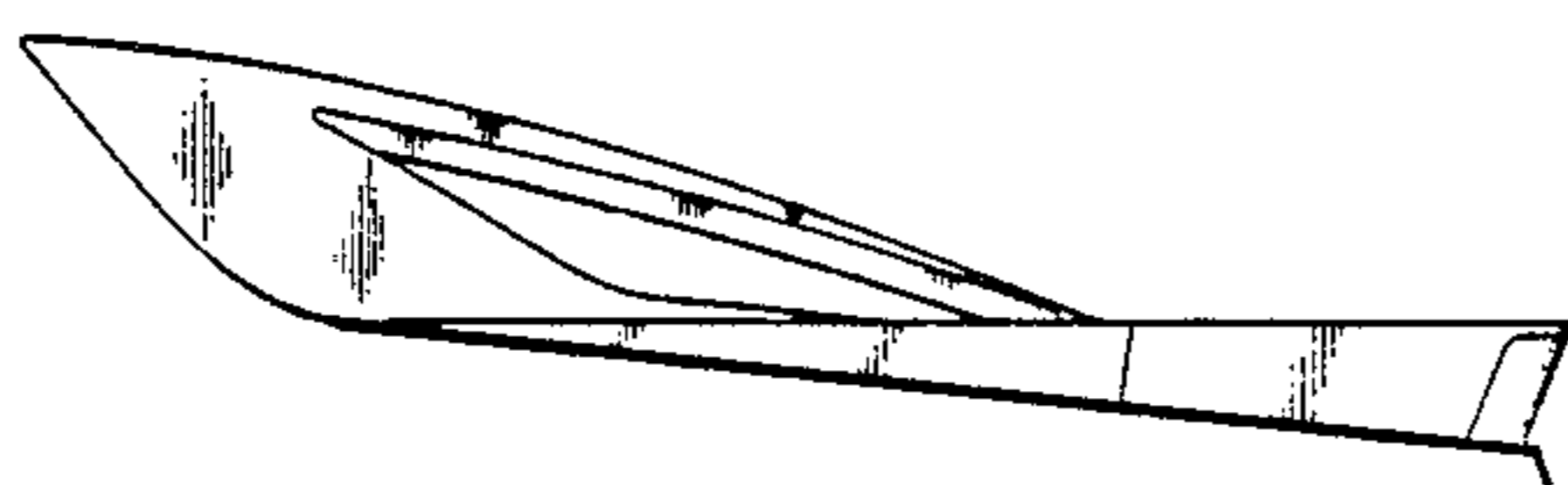

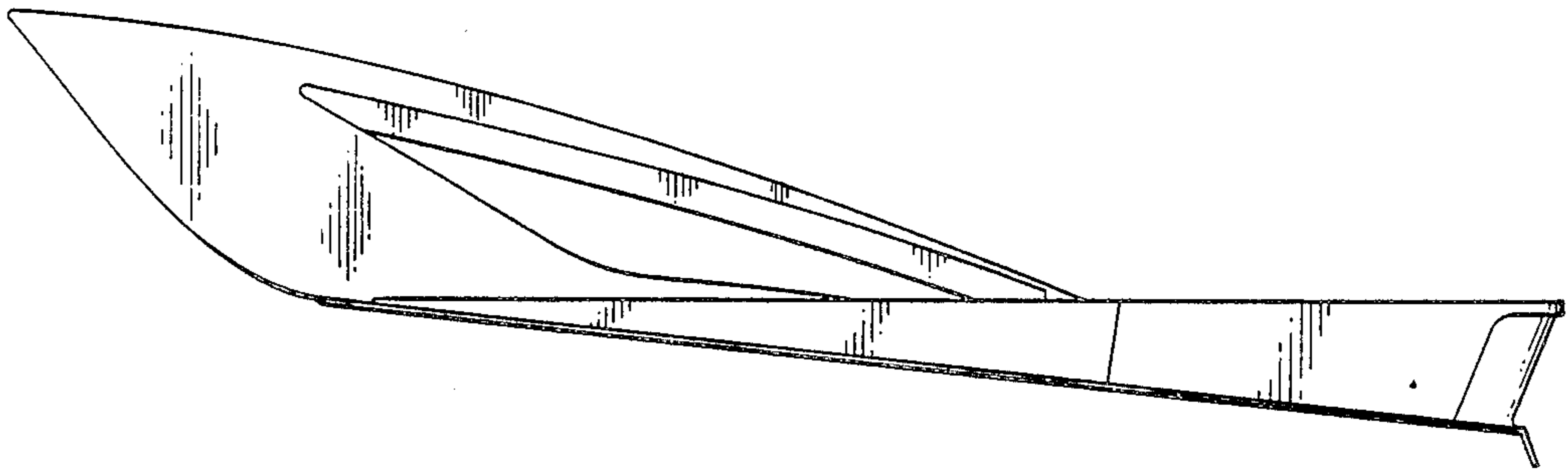

FIG. 1

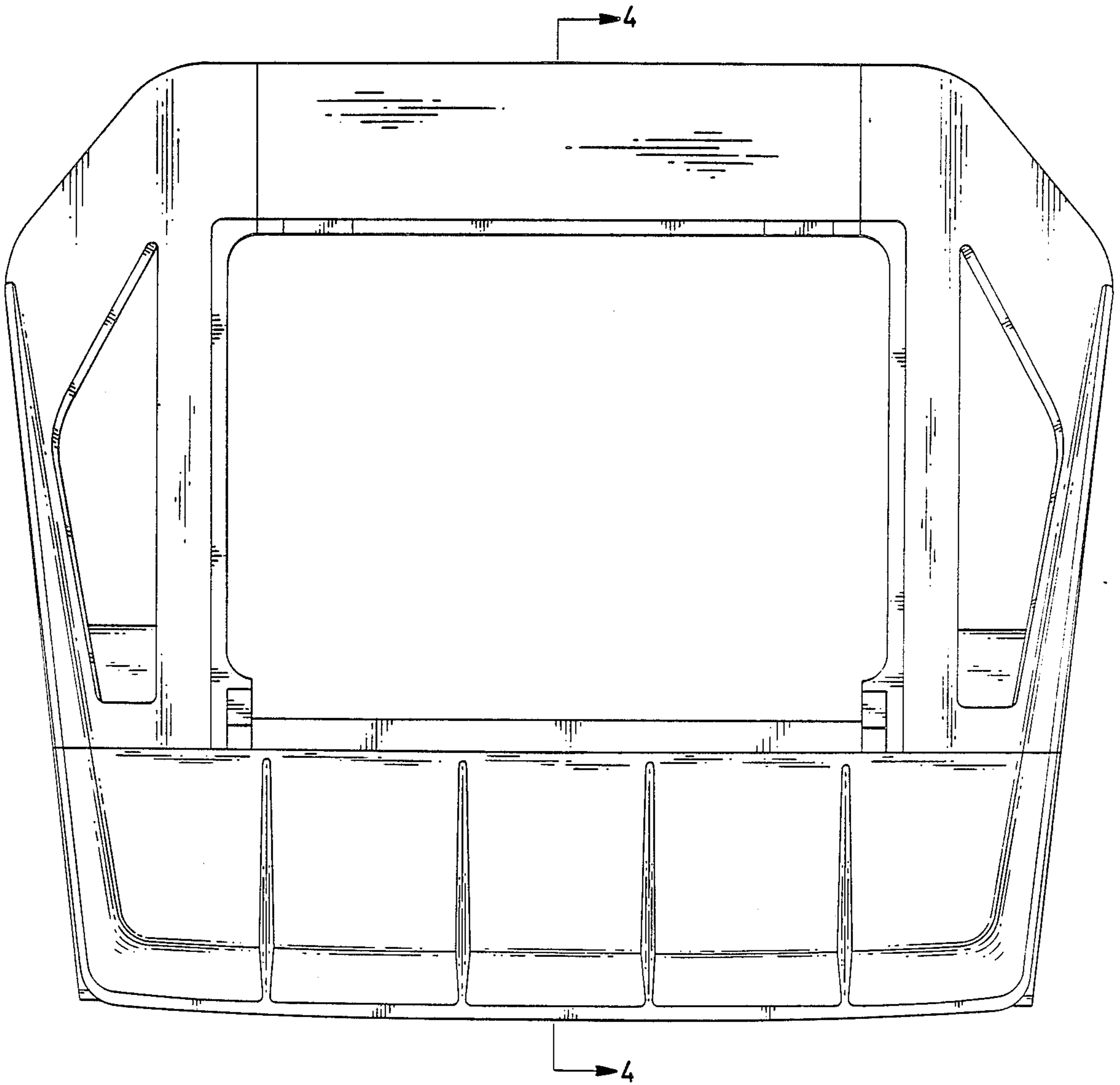

FIG. 2

FIG. 3

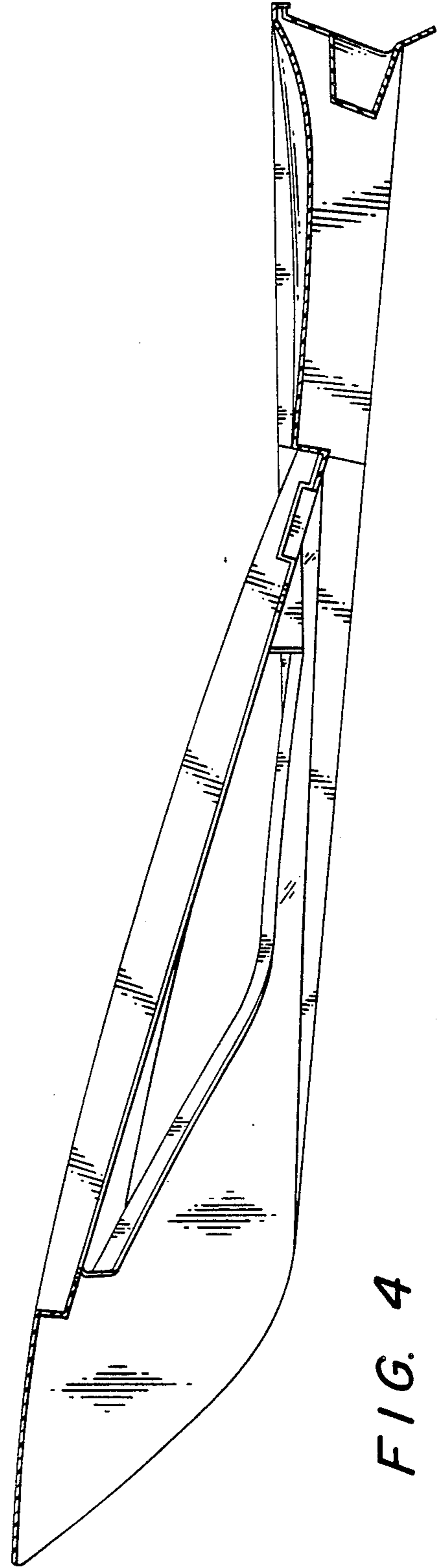
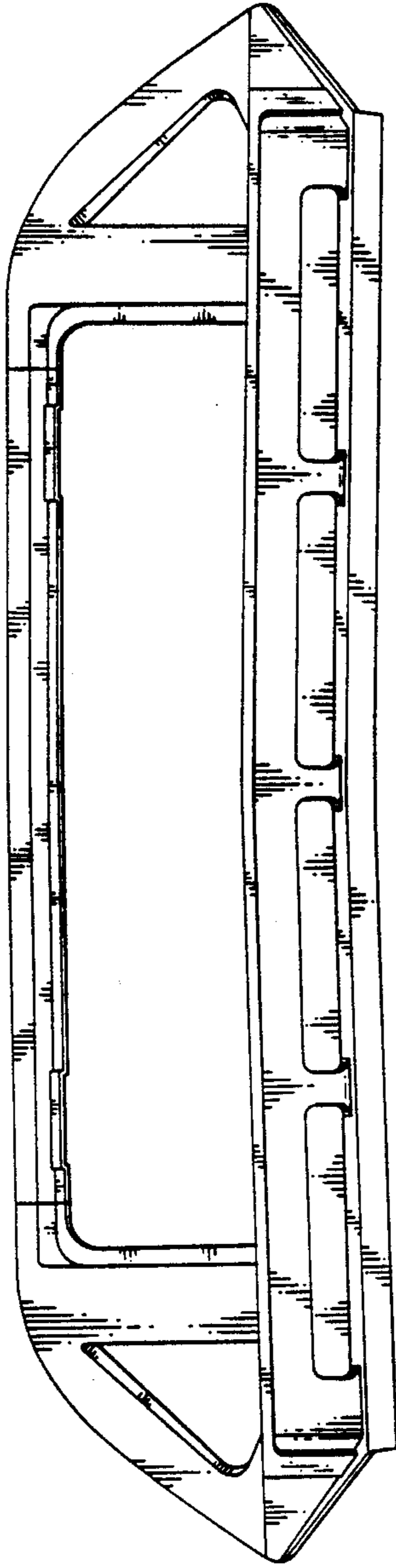

FIG. 4